

**ILLUSTRATED  
PARTS CATALOG**

**for**

**IO-520 SERIES**

**AIRCRAFT ENGINES**

**NOTICE:**

Part numbers appearing herein are trademarks of  
Continental Motors Corporation.

**CURRENT STATUS OF PAGES AS OF**

**MAY 1, 1969**

**THE ORIGINAL DATE OF THIS PUBLICATION IS MAY 1, 1969**

**INSERT LATEST PAGES. DESTROY SUPERSEDED PAGES.**

**MODEL 10-520 PARTS CATALOG FORM X-30040A**

<b>PAGE</b>	<b>STATUS</b>	<b>PAGE</b>	<b>STATUS</b>	<b>PAGE</b>	<b>STATUS</b>
i .....	May 1969	35 .....	May 1969	B1 .....	May 1969
ii .....	May 1969	36 .....	May 1969	B2 .....	Blank
iii .....	May 1969	37 .....	May 1969	B3 .....	May 1969
iv .....	Blank	38 .....	May 1969	B4 .....	Blank
v .....	May 1969	39 .....	May 1969		
vi .....	May 1969	40 .....	May 1969		
		41 .....	May 1969		
		42 .....	May 1969	C1 .....	May 1969
1 .....	May 1969	43 .....	May 1969	C2 .....	Blank
2 .....	May 1969	44 .....	May 1969		
3 .....	May 1969	45 .....	May 1969		
4 .....	May 1969	46 .....	May 1969		
5 .....	May 1969	47 .....	May 1969	D1 .....	May 1969
6 .....	May 1969	48 .....	May 1969	D2 .....	May 1969
7 .....	May 1969	49 .....	May 1969	D3 .....	May 1969
8 .....	May 1969	50 .....	May 1969	D4 .....	May 1969
9 .....	May 1969	51 .....	May 1969	D5 .....	May 1969
10 .....	May 1969	52 .....	May 1969	D6 .....	Blank
11 .....	May 1969	53 .....	May 1969	D7 .....	May 1969
12 .....	May 1969	54 .....	May 1969	D8 .....	Blank
13 .....	May 1969	55 .....	May 1969	D9 .....	May 1969
14 .....	May 1969	56 .....	May 1969	D10 .....	Blank
15 .....	May 1969	57 .....	May 1969	D11 .....	May 1969
16 .....	May 1969	58 .....	May 1969	D12 .....	May 1969
17 .....	May 1969	59 .....	May 1969	D13 .....	May 1969
18 .....	May 1969	60 .....	May 1969	D14 .....	May 1969
19 .....	May 1969	61 .....	May 1969	D15 .....	May 1969
20 .....	May 1969	62 .....	May 1969	D16 .....	May 1969
21 .....	May 1969			D17 .....	May 1969
22 .....	May 1969			D18 .....	May 1969
23 .....	May 1969				
24 .....	May 1969	A1 .....	May 1969		
25 .....	May 1969	A2 .....	Blank		
26 .....	May 1969	A3 .....	May 1969	F1 .....	May 1969
27 .....	May 1969	A4 .....	May 1969	F2 .....	May 1969
28 .....	May 1969	A5 .....	May 1969	F3 .....	May 1969
29 .....	May 1969	A6 .....	May 1969	F4 .....	May 1969
30 .....	May 1969	A7 .....	May 1969	F5 .....	May 1969
32 .....	May 1969	A8 .....	May 1969	F6 .....	Blank
33 .....	May 1969	A9 .....	May 1969	F7 .....	May 1969
34 .....	May 1969	A10 .....	May 1969	F8 .....	Blank

# TABLE OF CONTENTS

SECTION I	PAGE	CODE
CURRENT STATUS OF PAGES . . . . .	ii	All
INTRODUCTION . . . . .	v	All
ABBREVIATIONS AND SYMBOLS . . . . .	v	All
ACCESSORY MANUFACTURERS . . . . .	vi	All
 SECTION II . . . . .	 vi	 All
GROUP ASSEMBLY PARTS LIST . . . . .	vi	All
USABLE ON CODE . . . . .	vi	All
Figure 1 - Crankcase Studding Assembly . . . . .	1	ADEFJKL
Figure 2 - Crankcase Attaching Parts . . . . .	3	ADEFJKL
Figure 3 - Crankcase Associated Parts . . . . .	5	ADEFJKL
Figure 4 - Crankcase Studding Assembly . . . . .	6	BC
Figure 5 - Crankcase Attaching Parts . . . . .	7	BC
Figure 6 - Crankcase Associated Parts . . . . .	8	BC
Figure 7 - Crankshaft Group . . . . .	10	ADEFJKL
Figure 8 - Crankshaft Group . . . . .	11	BC
Figure 9 - Camshaft Group . . . . .	12	ADEFJKL
Figure 10 - Camshaft Group . . . . .	13	BC
Figure 11 - Connecting Rod Assembly . . . . .	14	All
Figure 12 - Piston and Pin Assembly . . . . .	14	All
Figure 13 - Cylinder Assembly . . . . .	15	All
Figure 14 - Oil Pump Assembly . . . . .	16	ADEFJKL
Figure 15 - Oil Pump Assembly . . . . .	18	BC
Figure 16 - Starter and Starter Adapter Assy . . . . .	20	ADEFJKL
Figure 17 - Starter and Starter Adapter Assy . . . . .	22	BC
Figure 18 - Generator Assembly . . . . .	24	A
Figure 19 - Alternator Assembly . . . . .	25	BC
Figure 20 - Generator Assembly . . . . .	26	E
Figure 21 - Alternator Assembly . . . . .	27	K
Figure 22 - Oil Cooler . . . . .	28	ADEFJKL
Figure 23 - Oil Cooler . . . . .	29	BC
Figure 24 - Oil Sump . . . . .	30	ACDEFK
Figure 25 - Oil Sump . . . . .	31	B
Figure 26 - Oil Sump . . . . .	32	JL
Figure 27 - Fuel Induction System . . . . .	33	D
Figure 28 - Fuel Induction System . . . . .	36	ABCFJKL
Figure 29 - Fuel Induction System . . . . .	36	E
Figure 30 - Fuel Injection System . . . . .	39	AFJKL
Figure 31 - Fuel Injection System . . . . .	41	B
Figure 32 - Fuel Injection System . . . . .	43	C
Figure 33 - Fuel Injection System . . . . .	45	D
Figure 34 - Magneto & Accessory Drive Assy . . . . .	46	All
Figure 35 - Ignition System . . . . .	47	ADFJKL
Figure 36 - Ignition System . . . . .	49	BCE
 SECTION III - OVER & UNDERSIZE LIST . . . . .	 51	 All
 SECTION IV - REPAIR SETS & MATERIALS . . . . .	 52	 All
 SECTION V - NUMERICAL PARTS LIST . . . . .	 53	 All
 SECTION VI - CUSTOMER SPECIFICATIONS		

# SECTION I

## INTRODUCTION

1-1. In line with the Continental Motors Corporation program of product improvement, this parts catalog is presented in looseleaf form. Changes will be issued as they occur to those pages which are affected only. In this manner, the parts catalogs will be kept current at all times with manufacturing and service requirements. Changes to this and all subsequent parts catalogs produced in this manner will be available at the nearest Approved Distributor or from the Continental Motors Product Support Center, Elk Grove Village, Illinois 60007.

1-2. Page ii of this publication depicts the current status of pages as of the date listed. Each page in the catalog is also dated. To be current, the date on the page should match the date listed for that page on the Status Page. With each change to the catalog issued, a change to the current Status Page will necessarily be issued.

1-3. In this edition, currently available parts are listed for models IO-520-A through IO-520-L. If accessories or parts attached to any engine installed in an aircraft manufactured in the United States under a production model number do not appear in this catalog, determine whether they are available from the aircraft manufacturer before placing an order with a Continental Authorized Distributor.

1-4. Section II contains 36 figures, in each of which one of the major assemblies or groups of the engine is illustrated in "exploded" form. Each figure has its own set of index numbers to indicate the sub-parts. The list of parts in the assembly or group appears on the same page with the illustration or on an adjacent page. The first column of each assembly group list contains the figure number (not repeated on all lines) and, following a dash, the index numbers of the sub-parts in numerical order. Do not order parts by index number. Use the part number, which appears in the second column. Use the name of the part which appears in the column under the title "DESCRIPTION".

1-5. Do not order any parts listed herein when "NO NUMBER" appears on the same line in the part number column or when "NOT SOLD" herein abbreviated as "NS" appears in the "UNITS PER ASSEM" column,

because these parts are not suitable for installation without factory equipment, or they are major parts of assemblies and are more economically supplied in the assembled condition, or they are assemblies which would have to be disassembled for installation. To replace any detail part "NOT SOLD" order the smallest assembly containing the part (listed above, with name beginning one column to left). To replace any assembly "NOT SOLD", order whatever subassemblies and detail parts (listed below it, with names identical) that are in need of replacement.

1-6. Quantities of parts, as listed in Section II, are for specific application in one assembly. Total quantities of all parts are listed in Section V. Similar assemblies listed in Section II are combined, and quantities of sub-parts are for one assembly. Application code letters in the last column indicate on which models assemblies and sub-parts are used. Sub-parts have the same code letter as their parent assembly.

1-7. Oversize and undersize parts are listed in Section III. These parts must be ordered by the numbers listed herein, with correct descriptions, to avoid errors. Corresponding standard size part numbers in Section II are preceded by a symbol (†) to indicate the availability of the non-standard size. (Refer to list of abbreviations and symbols.)

1-8. Sets of parts listed in Section IV are usually wanted in such groups for overhaul work and should be ordered by set part numbers.

1-9. Section V contains a list of part numbers arranged in numerical order in the first column. If the number of any desired part is known the name may be located by referring to the figure and index number in Section II, which is listed opposite the part number in Section V.

1-10. Section VI contains a parts listing of customer specifications of the basic engines of each model. Only the differences between the customer specification and the basic engine are shown.

Only those specifications which were sold in quantities of 25 or more are covered herein.

### LIST OF ABBREVIATIONS AND SYMBOLS

SYMBOL	DEFINITION	SYMBOL	DEFINITION
AR	As Required	PD	Pitch diameter (thread)
dia.	Diameter	RF	Refer to
ID	Inside diameter	NPT	National Pipe Tap (or thread)
in.	Inches	US	Undersize
mm	Millimeters	No.	Number
OD	Outside diameter	†	Oversize parts available
OP	Optional	†	Undersize parts available
OS	Oversize	- - - * - - -	End of group of attaching parts
	NS		Not Sold
	\$		Parts included in a set

## ACCESSORY MANUFACTURERS

ACCESSORY	MANUFACTURER	ADDRESS
Generator/Alternator	Delco-Remy	United Motors Service General Motors Bldg. Detroit, Michigan 48200
	Prestolite	The Prestolite Company Div. of Eltra Corporation 511 Hamilton Street Toledo, Ohio 43601
Starter	Delco-Remy	United Motors Service General Motors Bldg. Detroit, Michigan
	Prestolite	The Prestolite Company Div. of Eltra Corporation 511 Hamilton Street Toledo, Ohio 43601
Magnetos	Slick Electro, Inc.	Slick Electro, Inc. Rockford, Illinois 61100
	Scintilla	Scintilla Magneto Division, Bendix Aviation Corporation Sidney, New York 13838

## USABLE ON CODE

MODEL	CODE
IO-520-A	A
IO-520-B	B
IO-520-C	C
IO-520-D	D
IO-520-E	E
IO-520-F	F
IO-520-J	J
IO-520-K	K
IO-520-L	L

FIGURE & INDEX NO.	PART NUMBER	DESCRIPTION	UNITS	USABLE
			PER ASS'Y.	ON CODE
		1 2 3 4 5 6 7		
1-	No Number	Crankcase, Complete . . . . .	NS	ADEFJKL
	631596	. Studding Assembly, Crankcase. . . . .	1	ADEFJK
	634685	. Studding Assembly, Crankcase. . . . .	1	L
- 1	No Number	. . Crankcase, 1-3-5 Side . . . . .	NS	ADEFJKL
- 2	No Number	. . Crankcase, 2-4-6 Side . . . . .	NS	ADEFJKL
- 3	537721	. . Bearing, Needle . . . . .	1	ADEFJKL
- 4	531548	. . Dowel, 5/16 X 11/16 In. Lg. . . . .	2	ADEFJKL
- 5	MS122162	. . Insert, Thread . . . . .	5	ADEFJKL
- 6	401808	† . . Stud, 1/4 X 1-5/16 In. Lg. . . . .	5	ADEFJKL
- 7	401814	† . . Stud, 5/16 X 1-7/8 In. Lg. . . . .	4	ADEFJKL
- 8	401861	† . . Stud, 3/8 X 1-3/4 In. Lg. . . . .	16	ADEFJKL
- 9	401870	† . . Stud, 1/4 X 1-1/8 In. Lg. . . . .	2	ADEFJKL
-10	401885	† . . Stud, 5/16 X 1-5/16 In. Lg. . . . .	12	ADEFJKL
-11	401893	† . . Stud, 1/4 X 1-1/4 In. Lg. . . . .	1	ADEFJKL
-12	401965	† . . Stud, 3/8 X 1-17/32 In. Lg. . . . .	2	ADEFJKL
-13	402129	† . . Stud, 1/4 X 2-3/4 In. Lg. . . . .	2	ADEFJKL
-14	402151	† . . Stud, 5/16 X 1-1/4 In. Lg. . . . .	2	ADEFJKL
-15	402158	† . . Stud, 1/4 X 4-13/32 In. Lg. . . . .	5	ADEFJKL
-16	402159	† . . Stud, 1/4 X 4-3/32 In. Lg. . . . .	2	ADEFJKL
-17	531590	† . . Stud, 5/16 X 1-1/8 In. Lg. . . . .	1	ADEFJL
-18	535956	† . . Stud, No. 10 X 5/8 In. Lg. . . . .	4	ADEFJKL
-19	538404	† . . Stud, 7/16 X 1-19/32 In. Lg. . . . .	24	ADEFJKL
-20	631867	† . . Stud, 7/16 X 2-1/16 In. Lg. . . . .	12	ADEFJKL
-21	2024	. . Plug, 1/8-27 NPT . . . . .	1	ADEFJKL
-22	2025	. . Plug, 3/8-18 NPT . . . . .	4	ADEFJKL
-23	629518-1	. . Plug, 1/8-27 NPTF. . . . .	1	ADEFJKL
-24	629518-3	. . Plug, 3/8-18 NPTF. . . . .	2	ADEFJKL
-25	532432	. . Plug, Machine Thd, 5/8-18 . . . . .	1	ADEFJKL
-26	AN900-10	\$ . . Gasket, Copper. . . . .	1	ADEFJKL
-27	631927	. . Housing, Oil Gauge Rod . . . . .	1	ADEFJKL
-28	537299	. . Ring, Oil Gauge Lock . . . . .	1	ADEFJKL
-29	537505	. . Breather Assembly, Crankcase . . . . .	1	ADEFJKL
-30	629847	. . Nozzle, Squirt . . . . .	6	ADEFJKL
-31	629846	. . Screen, Squirt, Nozzle . . . . .	6	ADEFJKL

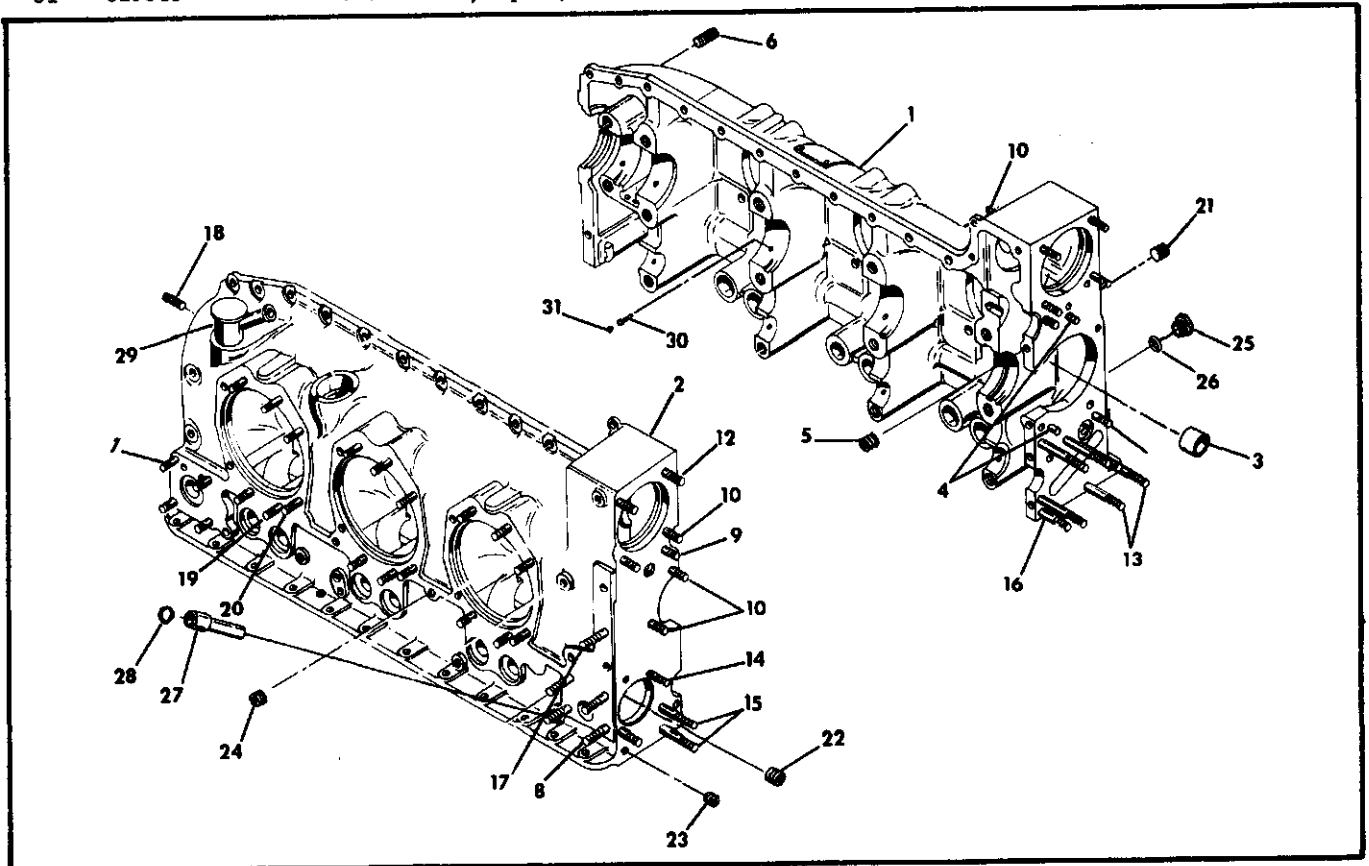

Figure 1. Crankcase Studding Assembly.

FIGURE & INDEX NO.	PART NUMBER	DESCRIPTION	UNITS PER ASSY.	USABLE ON CODE		
					1	2
2-	No Number	Crankcase Assembly . . . . .	1	ADEFJKL		
- 1	538944-10.50	. Bolt, Crankcase Thru. . . . .	4	ADEFJKL		
- 2	538944-8.88	. Bolt, Crankcase Thru. . . . .	2	ADEFJKL		
- 3	539050-9.81	. Bolt, Crankcase Thru. . . . .	1	ADEFJKL		
- 4	539050-10.75	. Bolt, Crankcase Thru. . . . .	7	ADEFJKL		
- 5	25171	. Spacer, Crankcase Thru Bolt . . . . .	12	ADEFJKL		
- 6	531001	. Nut, Flanged Crankcase Thru Bolt . . . . .	12	ADEFJKL		
- 7	2958	. Palnut, Crankcase Thru Bolt . . . . .	12	ADEFJKL		
- 8	538989	. Washer, Plain, 1/2 In. . . . .	3	ADEFJL		
- 8	538989	. Washer, Plain, 1/2 In. . . . .	4	K		
- 9	539952	. Nut, Plain, 1/2-20 . . . . .	3	ADEFJKL		
-10	AN356-820	. Palnut. . . . .	3	ADEFJKL		
-11	AN5-12A	. Bolt. . . . .	9	ADEFJKL		
-12	AN960-516	. Washer, Plain . . . . .	12	ADEFJKL		
-13	AN936A516	. Washer, Lock . . . . .	12	ADEFJKL		
-14	AN315-5R	. Nut, Plain, Hex . . . . .	12	ADEFJKL		
-15	AN123861	\$ . O-Ring . . . . .	1	ADEFJKL		
-16	401506	. Washer, Plain . . . . .	1	ADEFJKL		
-17	2473	. Washer, Plain . . . . .	3	ADEFJL		
-17	2473	. Washer, Plain . . . . .	4	K		
-18	627433	. Bolt, 5/16-18 X 5-1/4 In. Lg. . . . .	4	ADEFJ		
-18	627433	. Bolt, 5/16-18 X 5-1/4 In. Lg. . . . .	5	KL		
-19	AN123862	\$ . O-Ring . . . . .	2	ADEFJKL		
-20	24239	. Washer, Plain . . . . .	2	ADEFJKL		
-21	AN936A616	. Washer, Lock . . . . .	1	ADEFJKL		
-22	535810	. Bolt, 3/8-24 X 9-13/16 In. Lg. . . . .	1	ADEFJKL		
-23	2441	. Nut, Plain, Hex . . . . .	1	ADEFJKL		
-24	No Number	. Manifold Valve & Bracket Assembly, Fuel . . . . .	NS	ADEFJKL		
ATTACHING PARTS						
-25	AN960-516	. Washer, Plain . . . . .	2	ADEFJKL		
-26	AN5-12A	. Bolt. . . . .	1	ADEFJKL		
-27	AN936A516	. Washer, Lock . . . . .	1	ADEFJKL		
-28	AN315-5R	. Nut, Plain, Hex . . . . .	1	ADEFJKL		
- - - * - - -						
-29	538650	. Eye, Engine Lifting. . . . .	1	ADEFJKL		
ATTACHING PARTS						
-30	538949	. Washer, Crankcase-to-Lifting Eye . . . . .	1	ADEFJKL		
-31	AN5-14A	. Bolt. . . . .	2	ADEFJKL		
-32	AN960-516	. Washer, Plain . . . . .	2	ADEFJKL		
-33	AN936A516	. Washer, Lock . . . . .	2	ADEFJKL		
-34	AN315-5R	. Nut, Plain, Hex . . . . .	2	ADEFJKL		
- - - * - - -						
-35	626990	. Clip, Oil Transfer . . . . .	1	ADEFJKL		
ATTACHING PARTS						
-36	AN500A10-4	. Screw . . . . .	2	ADEFJKL		
- - - * - - -						
-37	634936	* . Plate, Identification . . . . .	1	A		
-37	633191	* . Plate, Identification . . . . .	1	D		
-37	633450	* . Plate, Identification . . . . .	1	E		
-37	633977	* . Plate, Identification . . . . .	1	F		
-37	635960	* . Plate, Identification . . . . .	1	J		
-37	636190	* . Plate, Identification . . . . .	1	K		
-37	636196	* . Plate, Identification . . . . .	1	L		
ATTACHING PARTS						
-38	24764	. Screw, Drive, 1/16 X 1/8 In. Lg. . . . .	6	ADEFJKL		
- - - * - - -						

NOTE: (\*) Return original plate with order. If not legible, also supply Model and Serial Number.

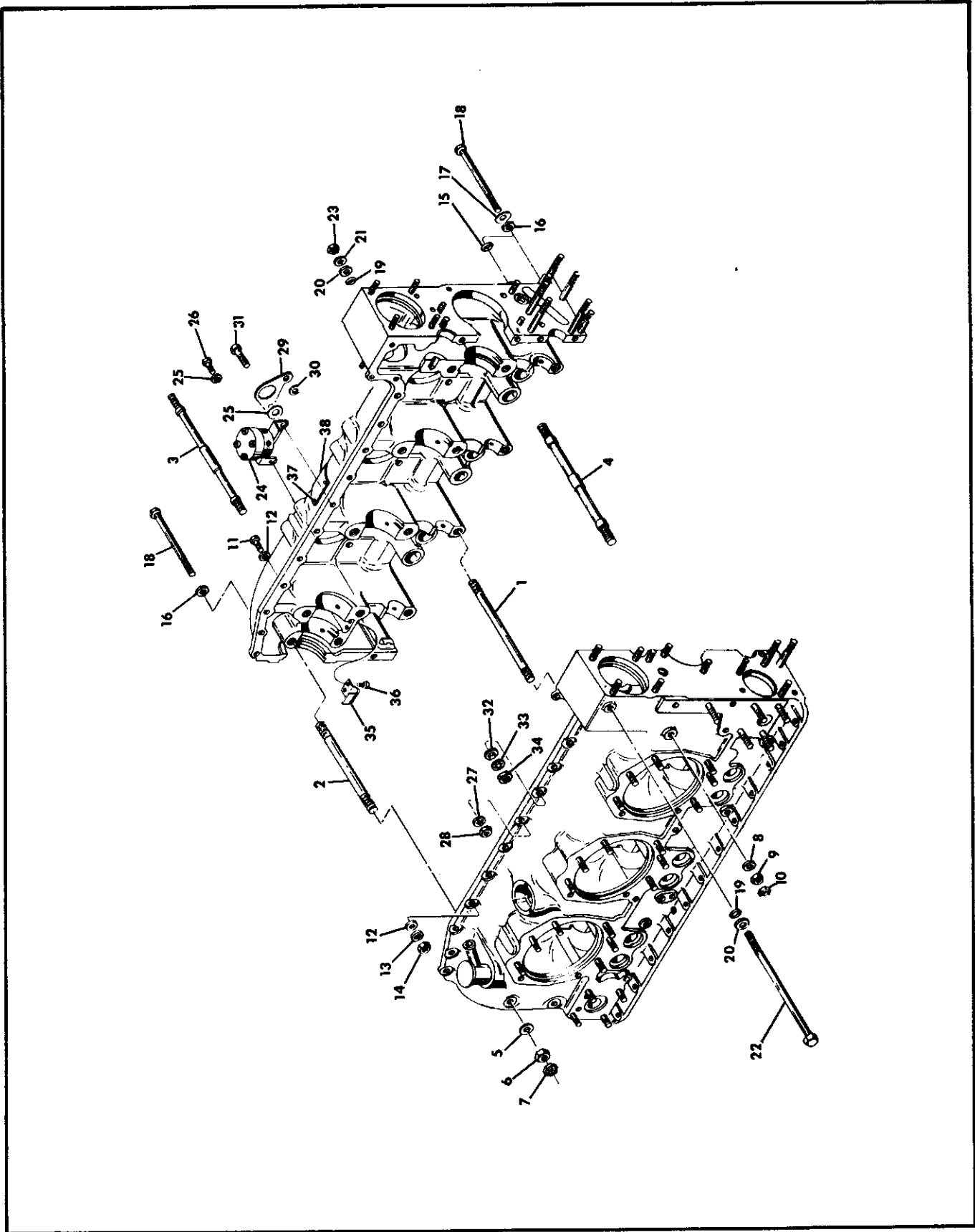

Figure 2. Crankcase Attaching Parts.



FIGURE & INDEX NO.	PART NUMBER	DESCRIPTION	UNITS PER ASS'Y.	USABLE ON CODE		
					1	2
3-	No Number	Crankcase Assembly . . . . .	NS	ADEFJKL		
- 1	539518	. Bracket, Engine Mount . . . . .	4	A		
- 1	539518	. Bracket, Engine Mount . . . . .	3	DEFJKL		
- 2	628257	. Bracket, Engine Mount, No. 2 Cylinder . . . . .	1	DEFJL		
- 2	634673	. Bracket, Engine Mount and Alternator . . . . .	1	K		
ATTACHING PARTS						
- 3	539058	. Washer, Plain . . . . .	16	ADEFJKL		
- 4	AN936A616	. Washer, Lock . . . . .	16	ADEFJKL		
- 5	2441	. Nut, Plain, Hex . . . . .	16	ADEFJKL		
- 6	632357	. Spacer, Bracket Engine Mount, No. 2 Cylinder . . . . .	1	DEFJL		
- 7	627690	. Bracket, Generator. - - - * - - - . . . . .	1	AEF		
ATTACHING PARTS						
- 8	538989	. Washer, Plain . . . . .	1	ADEFL		
- 9	538969	. Nut, Flanged . . . . .	1	ADEFL		
-10	AN356-820	. Palnut . . . . .	1	ADEFL		
-11	2794	. Washer, Plain . . . . .	1	AEF		
-12	AN936A516	. Washer, Lock . . . . .	1	ADEFL		
-13	AN315-5R	. Nut, Plain, Hex . . . . .	1	ADEFL		
-14	2473	. Washer, Plain . . . . .	1	ADEFL		
-15	AN936A516	. Washer, Lock . . . . .	1	ADEFL		
-16	627433	. Bolt, 5/16-18 X 5-1/4 In. Lg. . . . .	1	ADEFL		
-17	534740	\$ . Gasket, Idler Support Pin - - - * - - - . . . . .	1	ADEFJKL		
-18	534728	. Pin, Idler Gear Support . . . . .	1	ADEFJKL		
ATTACHING PARTS						
-19	AN936A416	. Washer, Lock . . . . .	2	ADEFJKL		
-20	2437	. Nut, Plain, Hex . . . . .	2	ADEFJKL		
ATTACHING PARTS						
-21	627412	. Valve Assembly, Vernatherm Control. . . . .	1	ADEFJKL		
-22	626963	. Retainer, Oil Seal & Felt . . . . .	2	ADEFJKL		
ATTACHING PARTS						
-23	AN960-10L	. Washer, Plain . . . . .	4	ADEFJKL		
-24	AN936A10	. Washer, Lock . . . . .	4	ADEFJKL		
-25	13XX1896	. Nut, Plain, Hex . . . . .	4	ADEFJKL		
-26	531083	\$ . Gasket, Governor Pad. - - - * - - - . . . . .	1	ADEFJKL		
-27	36181	. Cover, Governor Pad . . . . .	1	ADEFJKL		
ATTACHING PARTS						
-28	22535	. Washer, 5/16 X 9/16 X 1/4 In. Thick. . . . .	4	ADEFJKL		
-29	2473	. Washer, Plain . . . . .	4	ADEFJKL		
-30	AN936A516	. Washer, Lock . . . . .	4	ADEFJKL		
-31	AN315-5R	. Nut, Plain, Hex . . . . .	4	ADEFJKL		
-32	538804	\$ . Gasket, Oil Filler Neck - - - * - - - . . . . .	1	ADEFJKL		
-33	538801	. Neck Assembly, Oil Filler. . . . .	1	AEFJKL		
-33	538773	. Neck Assembly, Oil Filler. . . . .	1	D		
ATTACHING PARTS						
-34	AN500A416-8	. Screw . . . . .	3	ADEFJKL		
ATTACHING PARTS						
	539291	. Retainer Assembly, Oil Cap . . . . .	1	AEFJKL		
	631755	. Retainer Assembly, Oil Cap . . . . .	1	D		
	534632	. Cap Assembly, Oil Filler . . . . .	1	ADEFJKL		
-35	535823	. . . Gasket, Oil Filler . . . . .	1	ADEFJKL		
-36	No Number	. . . Cap, Oil Filler. . . . .	NS	ADEFJKL		
	632062-2A1	* . Rod Assembly, Oil Gauge, Complete . . . . .	1	AEF		
-37	AN123861	. . . O-Ring . . . . .	1	ADEFJKL		
-38	No Number	. . . Rod Assembly, Oil Gauge . . . . .	NS	AEFJKL		
-38	632062-4	* . Rod Assembly, Oil Gauge . . . . .	1	D		
-38	632062-15	* . Rod Assembly, Oil Gauge . . . . .	1	J		
-38	632062-12	* . Rod Assembly, Oil Gauge . . . . .	1	K		
-38	632062-16	* . Rod Assembly, Oil Gauge . . . . .	1	L		

NOTES: (\*) These parts shipped loose.  
 (#) When ordering oil gauge rod, supply engine model, airplane model and year airplane was built.

FIGURE & INDEX NO.	PART NUMBER	DESCRIPTION	UNITS	USABLE
			PER ASS'Y.	ON CODE
3-39	631928	. Hose, Housing Ext-to-Housing . . . . .	1	ADEFJKL
-40	631915	*. Housing, Ext, Oil Gauge Rod . . . . .	1	AEFJL
-40	632151	*. Housing, Ext, Oil Gauge Rod . . . . .	1	D
-40	634630	*. Housing, Ext, Oil Gauge Rod . . . . .	1	K
-41	36151R	*. Clamp, Hose, Worm Type. . . . .	2	ADEJKL
-42	631266-1	*. Clamp, Housing-to-Bracket . . . . .	1	ADEJKL
-43	631275-2	*. Bracket, No. 2 Cylinder Intake, Manifold Flange. . . . .	1	AEFJL
-43	632149	*. Bracket, Oil Gauge Housing . . . . .	1	D
ATTACHING PARTS				
-44	AN501-10-6	*. Screw . . . . .	1	ADEFJKL
-45	2471	*. Washer, Plain . . . . .	1	ADEFJKL
-46	AN936A10	*. Washer, Lock . . . . .	1	ADEFJKL
-47	13XX1896	*. Nut, No. 10-32 . . . . .	1	ADEFJKL

NOTES: (\*) These parts shipped loose.

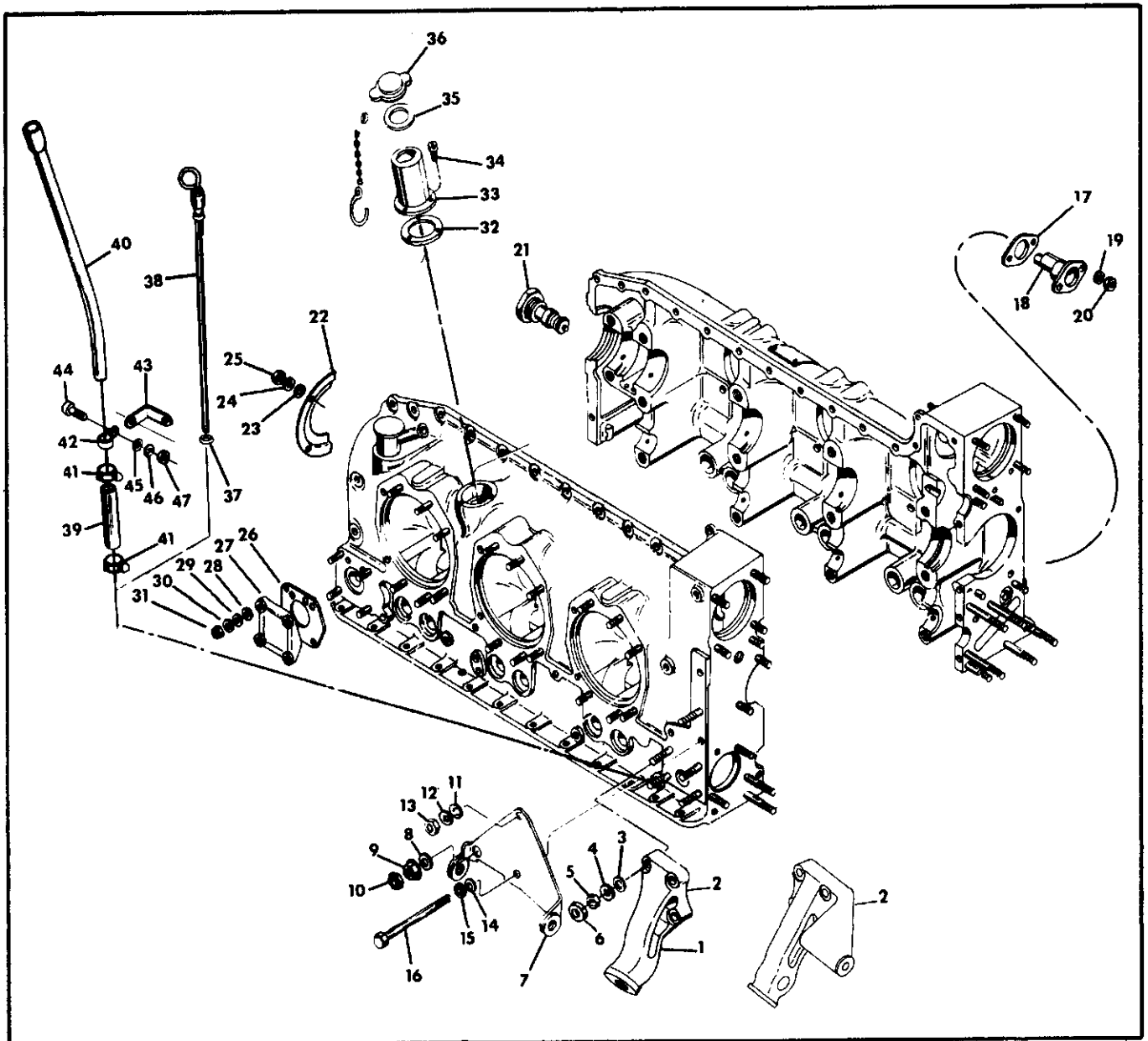

Figure 3. Crankcase Associated Parts.

FIGURE & INDEX NO.	PART NUMBER	DESCRIPTION	UNITS PER ASS'Y.							USABLE ON CODE	
			1	2	3	4	5	6	7		
4-	No Number	Crankcase, Complete . . . . .								NS	BC
	630969	. Studding Assembly, Crankcase. . . . .								1	B
	631096	. Studding Assembly, Crankcase. . . . .								1	C
- 1	No Number	. . Crankcase, 1-3-5 Side . . . . .								NS	BC
- 2	No Number	. . Crankcase, 2-4-6 Side . . . . .								NS	BC
- 3	630899	. . Bearing, Needle . . . . .								1	BC
- 4	630873	. . Dowel, 3/16 X 1/2 In. Lg. . . . .								1	BC
- 5	MS122122	. . Insert, Thread . . . . .								9	C
- 5	MS122122	. . Insert, Thread . . . . .								4	B
- 5	MS122162	. . Insert, Thread . . . . .								5	B
- 6	401804	† . . Stud, 1/4 X 1-1/8 In. Lg. . . . .								2	BC
- 7	401814	† . . Stud, 5/16 X 1-7/8 In. Lg. . . . .								4	BC
- 8	401836	† . . Stud, 5/16 X 7/8 In. Lg. . . . .								1	C
- 9	401842	† . . Stud, 3/8 X 2-9/16 In. Lg. . . . .								2	C
- 9	402127	† . . Stud, 3/8 X 1-19/32 In. Lg. . . . .								2	B
-10	401885	† . . Stud, 5/16 X 1-5/16 In. Lg. . . . .								10	B
-10	401885	† . . Stud, 5/16 X 1-5/16 In. Lg. . . . .								7	C
-11	401927	† . . Stud, 3/8 X 3-1/2 In. Lg. . . . .								3	BC
-12	401932	† . . Stud, 5/16 X 4-1/8 In. Lg. . . . .								2	BC
-13	401936	† . . Stud, 1/4 X 3-7/8 In. Lg. . . . .								5	BC
-14	401944	† . . Stud, 3/8 X 2-7/16 In. Lg. . . . .								3	C
-14	401965	† . . Stud, 3/8 X 1-13/32 In. Lg. . . . .								2	B
-15	401962	† . . Stud, 1/4 X 2-3/16 In. Lg. . . . .								1	BC
-16	401963	† . . Stud, 1/4 X 1 In. Lg. . . . .								2	BC
-17	401863	† . . Stud, 5/16 X 2-5/16 In. Lg. . . . .								2	C
-18	401977	† . . Stud, 3/8 X 2-3/32 In. Lg. . . . .								4	C
-19	402034	† . . Stud, 5/16 X 6 In. Lg. . . . .								1	B
-19	524183	† . . Stud, 5/16 X 6-7/8 In. Lg. . . . .								1	C
-20	402151	† . . Stud, 5/16 X 1-1/4 In. Lg. . . . .								2	BC
-21	402153	† . . Stud, 3/8 X 1-5/16 In. Lg. . . . .								2	BC
-22	535956	† . . Stud, No. 10 X 5/8 In. Lg. . . . .								4	BC
-23	631867	† . . Stud, 7/16 X 2-1/16 In. Lg. . . . .								36	BC
-24	401752	. . Plug, Pipe, 1/8-27 . . . . .								4	BC
-25	AN932C2	. . Plug, Pipe . . . . .								2	BC
-26	402941	. . Plug, Pipe, 1/16-27 . . . . .								4	BC
-27	2025	. . Plug, Pipe, 3/8-18 . . . . .								1	BC
-28	2265	. . Plug, Machine Thread, 5/8-18. . . . .								1	BC
-29	AN900-10	\$ . . Gasket, Copper. . . . .								1	BC
-30	629847	. . Nozzle, Squirt . . . . .								6	BC
-31	629846	. . Screen, Nozzle Squirt. . . . .								6	BC

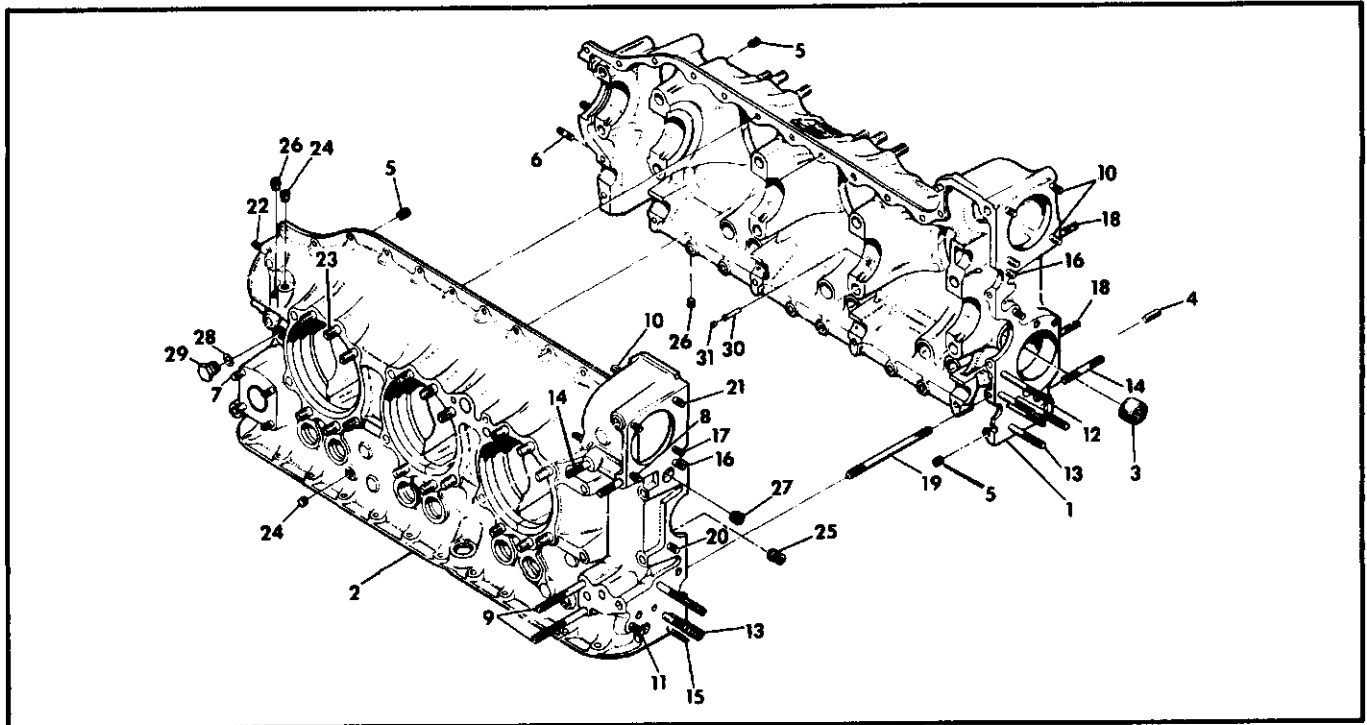

Figure 4. Crankcase Studding Assembly.

FIGURE & INDEX NO.	PART NUMBER	DESCRIPTION	UNITS PER ASSY.							USABLE ON CODE	
			1	2	3	4	5	6	7		
5-	No Number	Crankcase Assembly . . . . .								NS	BC
- 1	538944-5.31	. Bolt, Crankcase, Thru . . . . .								1	BC
- 2	538944-6.19	. Bolt, Crankcase, Thru . . . . .								1	BC
- 3	20202	. Washer, Plain . . . . .								4	BC
- 4	531001	. Nut, Flanged. . . . .								4	BC
- 5	2958	. Palnut. . . . .								4	BC
- 6	539050-10.75	. Bolt, Crankcase, Thru . . . . .								8	BC
- 7	630693-10.44	. Bolt, Crankcase, Thru . . . . .								1	B
- 7	630693-12.14	. Bolt, Crankcase, Thru . . . . .								1	C
- 8	AN123862	\$ O-Ring . . . . .								2	BC
- 9	24239	. Washer, Plain . . . . .								2	BC
-10	AN936A616	. Washer, Lock . . . . .								2	BC
-11	2441	. Nut, Plain, Hex . . . . .								2	BC
-12	No Number	. Manifold Valve & Bracket Assembly, Fuel . . . . .								NS	BC
ATTACHING PARTS											
-13	2473	. Washer, Plain . . . . .								2	BC
-14	AN5-12A	. Bolt. . . . .								1	C
-14	AN5-11A	. Bolt. . . . .								1	B
-15	AN936A516	. Washer, Lock . . . . .								1	BC
-16	AN315-5R	. Nut, Plain, Hex . . . . .								1	BC
* - - - - *											
-17	538650	. Eye, Engine Lifting. . . . .								1	BC
ATTACHING PARTS											
-18	538949	. Spacer, Crankcase-to-Lifting Eye . . . . .								2	BC
-19	539374	. Washer, Plain . . . . .								1	BC
-20	538607	. Bolt, 5/16-24 . . . . .								2	BC
-21	AN936A516	. Washer, Lock . . . . .								2	BC
-22	AN315-5R	. Nut, Plain, Hex . . . . .								2	BC
* - - - - *											

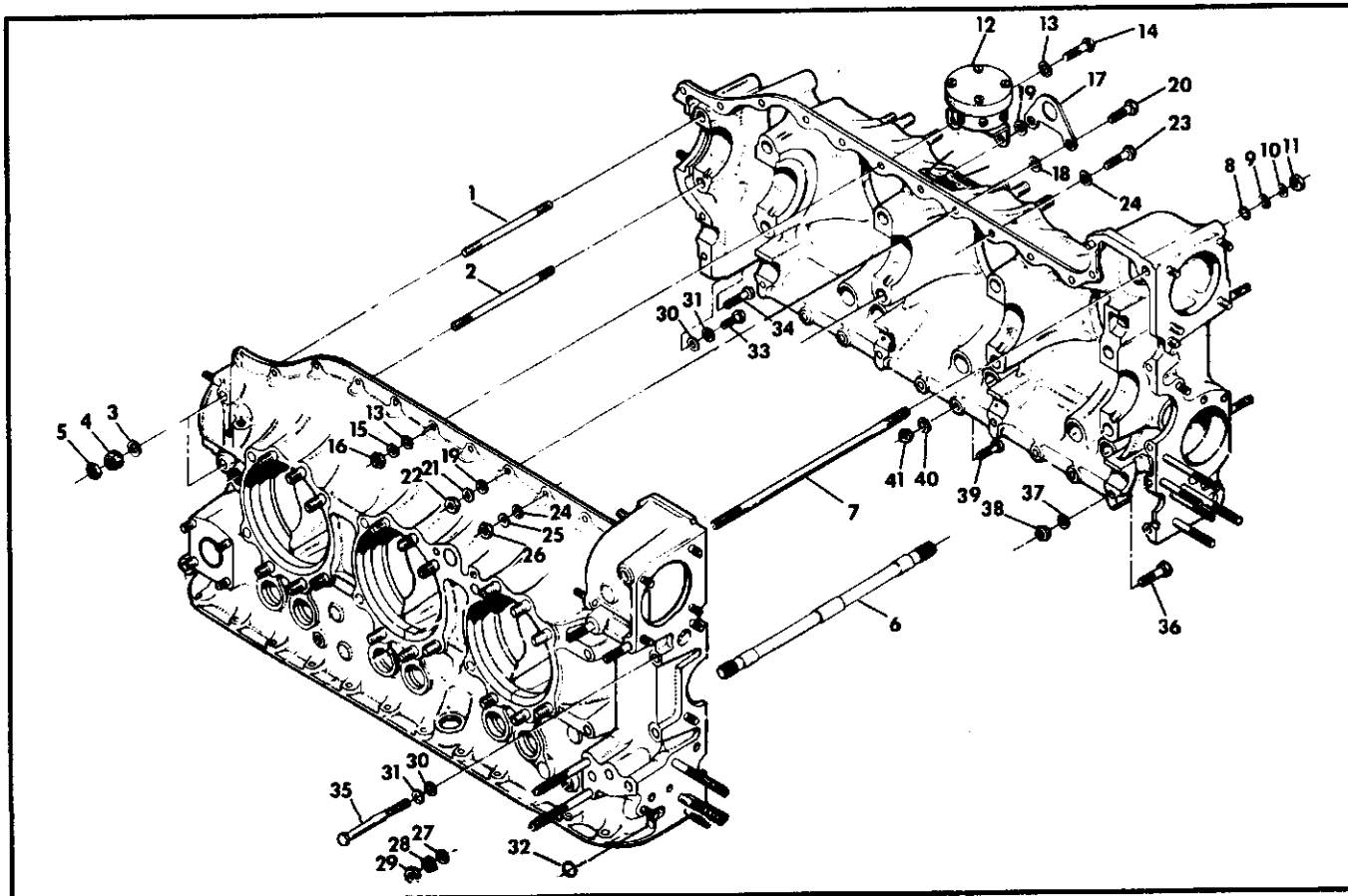

Figure 5. Crankcase Attaching Parts.

FIGURE & INDEX NO.	PART NUMBER	DESCRIPTION							UNITS PER ASS'Y.	USABLE ON CODE
		1	2	3	4	5	6	7		
5-23	AN5-11A	.	Bolt.	.	.	.	.	.	9	BC
-24	539374	.	Washer, Plain	.	.	.	.	.	11	BC
-25	AN936A516	.	Washer, Lock	.	.	.	.	.	12	BC
-26	AN315-5R	.	Nut, Plain, Hex	.	.	.	.	.	12	BC
-27	632120	.	Washer, Plain	.	.	.	.	.	4	C
-28	538969	.	Nut, Flanged, 1/2-20	.	.	.	.	.	16	BC
-29	AN356-820	.	Palnut	.	.	.	.	.	16	BC
-30	2473	.	Washer, Plain	.	.	.	.	.	5	BC
-31	AN936A516	.	Washer, Lock	.	.	.	.	.	5	BC
-32	AN123861	\$	O-Ring	.	.	.	.	.	1	BC
-33	537750	.	Bolt, 5/16-18 X 1-1/8 In. Lg.	.	.	.	.	.	1	BC
-34	539003	.	Bolt, 5/16-18 X 1-3/8 In. Lg.	.	.	.	.	.	1	BC
-35	630966-4.0	.	Bolt, 5/16-18 X 4 In. Lg.	.	.	.	.	.	3	BC
-36	MS20073-05.25	.	Bolt, 5/16-24 X 2-11/16 In. Lg.	.	.	.	.	.	4	BC
-37	2473	.	Washer, Plain	.	.	.	.	.	8	BC
-38	632443-6	.	Nut, Marsden Lock	.	.	.	.	.	4	BC
-39	AN4-13A	.	Bolt	.	.	.	.	.	6	B
-39	AN4-15A	.	Bolt	.	.	.	.	.	5	C
-40	20522	.	Washer, Plain	.	.	.	.	.	12	BC
-41	632443-4	.	Nut, Marsden Lock	.	.	.	.	.	6	BC

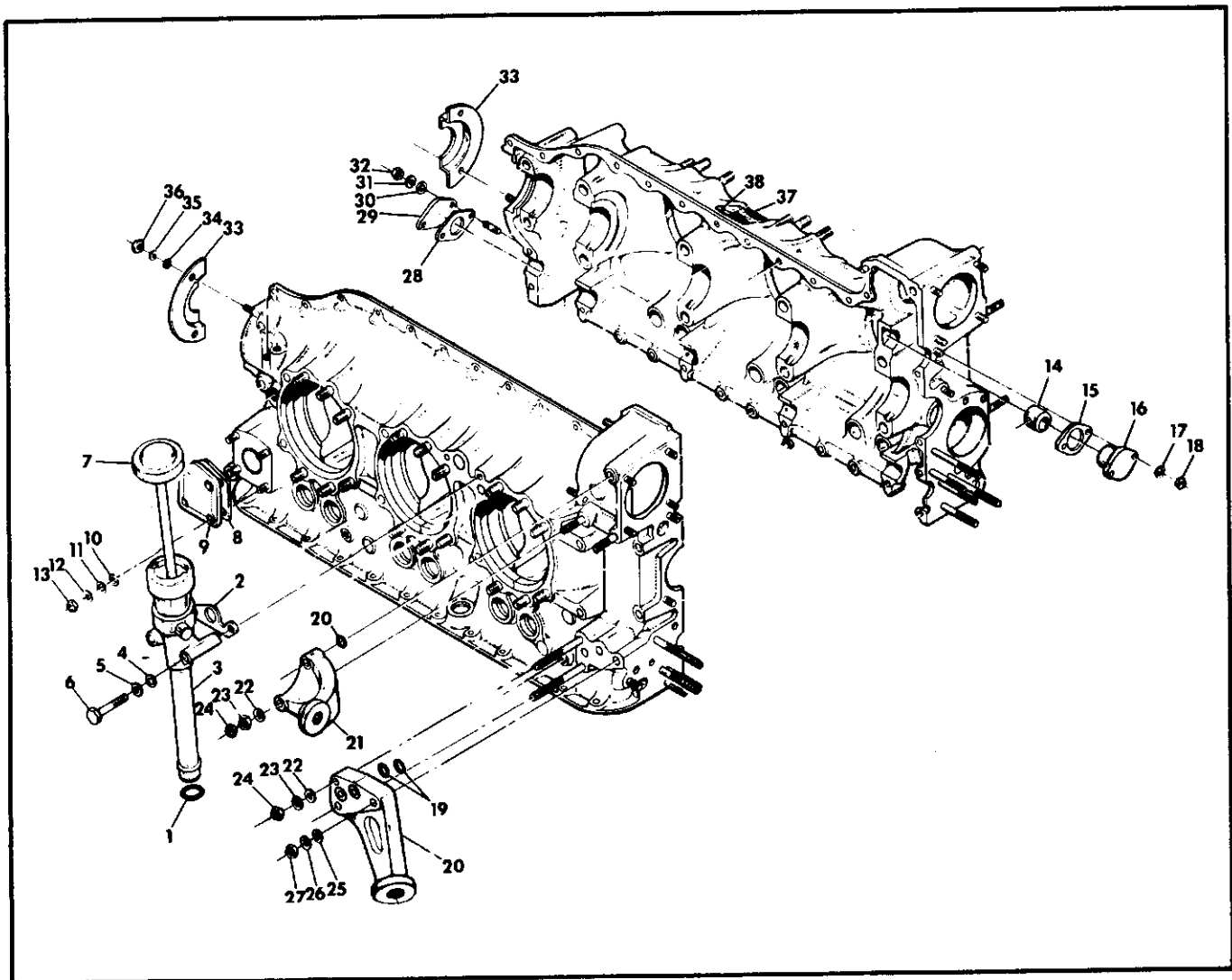

Figure 6. Crankcase Associated Parts.

FIGURE & INDEX NO.	PART NUMBER	DESCRIPTION	UNITS	USABLE
			PER ASS'Y.	ON CODE
		1 2 3 4 5 6 7		
6-	No Number	Crankcase Assembly . . . . .	NS	BC
	630969	. Studding Assembly, Crankcase (See Figure 4) . . . . .	RF	B
	631096	. Studding Assembly, Crankcase (See Figure 4) . . . . .	RF	C
- 1	MS9021-210	\$ . O-Ring . . . . .	1	BC
- 2	630892	. Gasket, Neck Assembly-to-Crankcase . . . . .	1	BC
- 3	632964-2	. Neck Assembly, Breather & Oil Filler . . . . .	1	B
- 3	632964-1	. Neck Assembly, Breather & Oil Filler . . . . .	1	C
ATTACHING PARTS				
- 4	2473	. Washer, Plain . . . . .	2	BC
- 5	AN936A516	. Washer, Lock . . . . .	2	BC
- 6	539605	. Screw, 5/16-18 X 2-3/8 In. Lg. . . . .	2	BC
* - - - *				
- 7	633233-3	* . Gauge & Cap Assembly, Oil . . . . .	1	B
- 7	No Number	* . Gauge & Cap Assembly, Oil, Complete . . . . .	NS	C
- 8	531083	\$ . Gasket, Governor-to-Crankcase . . . . .	1	BC
- 9	36181	. Cover, Governor Pad . . . . .	1	BC
ATTACHING PARTS				
-10	22535	. Spacer, Governor. . . . .	4	BC
-11	2473	. Washer, Plain . . . . .	4	BC
-12	AN936A516	. Washer, Lock . . . . .	4	BC
-13	AN315-5R	. Nut, Plain, Hex . . . . .	4	BC
* - - - *				
-14	630871	. Bushing, Idler Gear. . . . .	1	BC
-15	534740	. Gasket, Flange-to-Bushing . . . . .	1	BC
-16	630870	. Bushing, Flanged, Idler Gear . . . . .	1	BC
ATTACHING PARTS				
-17	AN936A416	. Washer, Lock . . . . .	2	BC
-18	AN315-4R	. Nut, Plain, Hex . . . . .	2	BC
* - - - *				
-19	MS9021-017	\$ . O-Ring . . . . .	2	C
-20	630694	. Bracket Assembly, Engine Mount, No. 1 Lower . . . . .	1	C
-20	630695	. Bracket Assembly, Engine Mount, No. 2 Lower . . . . .	1	C
-21	631394	. Bracket, Engine Mounting, No. 1 Upper. . . . .	1	C
-21	631393	. Bracket, Engine Mounting, No. 2 Upper. . . . .	1	C
ATTACHING PARTS				
-22	2474	. Washer, Plain . . . . .	9	C
-23	AN936A616	. Washer, Lock . . . . .	9	C
-24	2441	. Nut, Plain, Hex . . . . .	9	C
-25	2473	. Washer, Plain . . . . .	1	C
-26	AN936A516	. Washer, Lock . . . . .	1	C
-27	AN315-5R	. Nut, Plain, Hex . . . . .	1	C
* - - - *				
-28	629202	. Gasket, Camshaft Cover. . . . .	1	BC
-29	629201	. Cover, Camshaft Hole . . . . .	1	BC
ATTACHING PARTS				
-30	AN960-416L	. Washer, Plain . . . . .	2	BC
-31	AN936A416	. Washer, Lock . . . . .	2	BC
-32	AN315-4R	. Nut, Plain, Hex . . . . .	2	BC
* - - - *				
-33	626963	. Retainer, Oil Seal & Felt . . . . .	2	BC
ATTACHING PARTS				
-34	AN960-10L	. Washer, Plain . . . . .	4	BC
-35	AN936A10	. Washer, Lock . . . . .	4	BC
-36	13XX1896	. Nut, Plain, No. 10-32. . . . .	4	BC
* - - - *				
-37	634937	** . Plate, Identification . . . . .	1	B
-37	632020	** . Plate, Identification . . . . .	1	C
ATTACHING PARTS				
-38	24764	. Screw, Drive. . . . .	6	BC
* - - - *				

NOTE: (\*) When ordering oil gauge rod, supply engine model, airplane model and year airplane was built.

(\*\*) Return original plate with order. If not legible, also supply Model and Serial Number.

FIGURE & INDEX NO.	PART NUMBER	DESCRIPTION	UNITS PER ASS'Y.							USABLE ON CODE	
			1	2	3	4	5	6	7		
7-	631716A2	Crankshaft Assembly, Service . . . . .								1	ADEFJKL
- 1	No Number	. Crankshaft & Tubes . . . . .								NS	ADEFJKL
- 2	350998	† . Bushing, Damper . . . . .								8	ADEFJKL
- 3	633189	. Plug, Oil Control . . . . .								1	ADEFJKL
	631968	. Counterweight Assembly, 4th & 5th Order . . . . .								2	ADEFJKL
- 4	No Number	. Counterweight . . . . .								NS	ADEFJKL
- 5	350997	† . Bushing, Counterweight . . . . .								4	ADEFJKL
	352117	. Counterweight Assembly, 6th Order . . . . .								2	ADEFJKL
- 6	No Number	. Counterweight . . . . .								NS	ADEFJKL
- 7	350997	† . Bushing, Counterweight . . . . .								4	ADEFJKL
- 8	630261-27	. Pin, Damper, 4th Order . . . . .								2	ADEFJKL
- 9	630261-3	. Pin, Damper, 5th Order . . . . .								2	ADEFJKL
-10	630261-4	. Pin, Damper, 6th Order . . . . .								4	ADEFJKL
ATTACHING PARTS											
-11	635623	. Plate, Pin, Retaining . . . . .								16	ADEFJKL
-12	629104	. Ring, Retaining . . . . .								16	ADEFJKL
* - - - -											
-13	630464	\$† . Bearing, Crankshaft, Main . . . . .								10	ADEFJKL
-14	628136	\$† . Washer, Thrust . . . . .								4	ADEFJKL
-15	628750	† . Bearing, Connecting Rod . . . . .								6	ADEFJKL
-16	626739	Collar Assembly, Governor Oil Transfer . . . . .								1	ADEFJKL
-17	626889	. Roll, Pin . . . . .								2	ADEFJKL
-18	401893	† . Stud, 1/4 X 1-1/4 In. Lg. . . . .								2	ADEFJKL
-19	632443-4	. Nut, Marsden Lock, 1/4-28 . . . . .								2	ADEFJKL
-20	536563	Dowel, Crankshaft-to-Gear . . . . .								1	ADEFJKL
-21	536421	Gear, Crankshaft . . . . .								1	ADEFJKL
ATTACHING PARTS											
-22	X1454	Washer, Dowel Retaining . . . . .								1	ADEFJKL
-23	536379	Screw, 5/16-24 X 7/8 In. Lg. . . . .								6	ADEFJKL
* - - - -											
-24	626974	Seal Assembly, Oil . . . . .								1	ADEFJKL
-25	536615	Felt, Crankshaft, Oil Seal . . . . .								1	ADEFJKL
-26	AN123965	O-Ring . . . . .								1	ADEFJKL
-27	626890	Sleeve, Governor Oil Transfer . . . . .								1	ADEFJKL
	534757	Gear Assembly, Idler . . . . .								NS	ADEFJKL
-28	No Number	. Gear . . . . .								1	ADEFJKL
-29	534741	. Bushing . . . . .								1	ADEFJKL

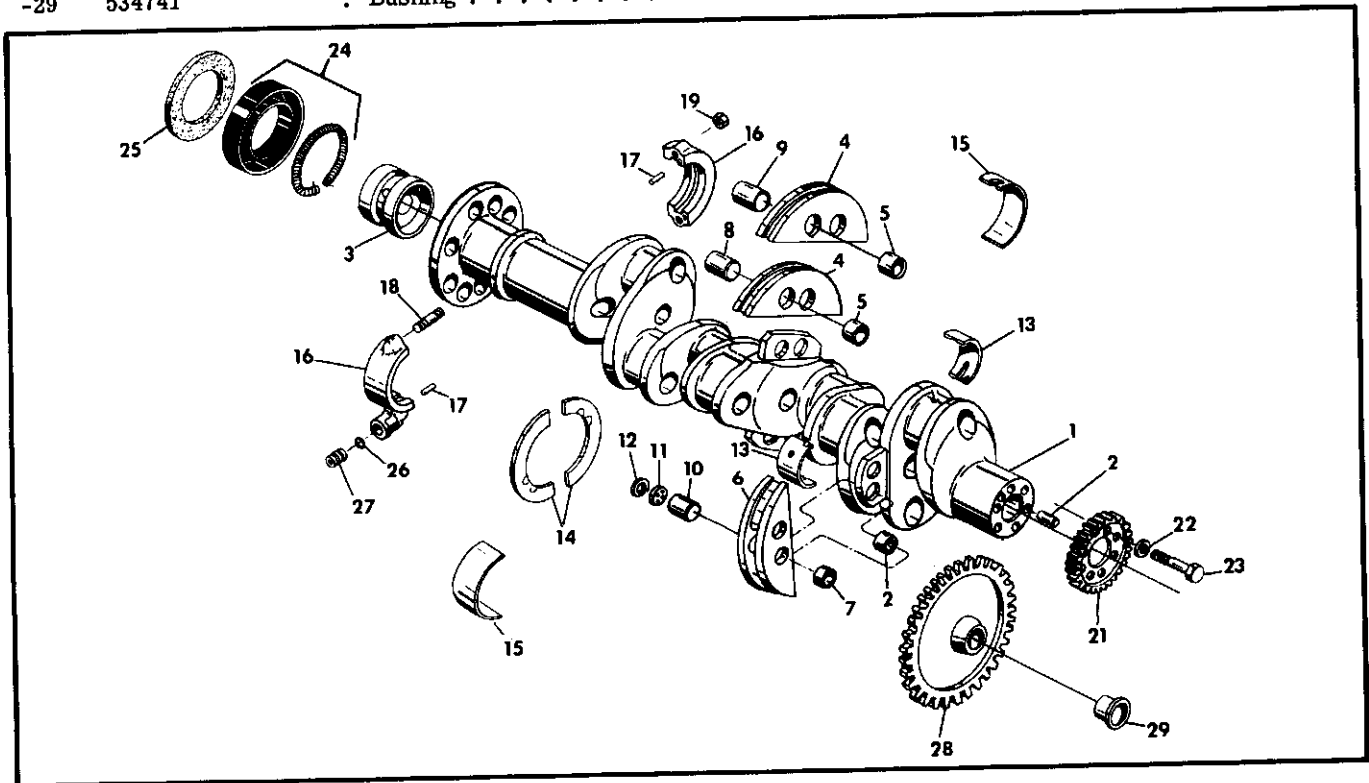

Figure 7. Crankshaft Group.

FIGURE & INDEX NO.	PART NUMBER	DESCRIPTION	UNITS PER ASS'Y.							USABLE ON CODE	
			1	2	3	4	5	6	7		
8-	633620A2	Crankshaft Assembly, Service . . . . .								1	BC
- 1	No Number	. Crankshaft & Tubes . . . . .								NS	BC
- 2	350998	† . Bushing, Crankshaft Damper . . . . .								8	BC
- 3	633189	. Plug, Oil Control . . . . .								1	BC
	631968	. Counterweight Assembly, 4th & 5th Order . . . . .								2	BC
- 4	No Number	. Counterweight . . . . .								NS	BC
- 5	350997	† . Bushing . . . . .								4	BC
	352117	. Counterweight Assembly, 6th Order . . . . .								2	BC
- 6	No Number	. Counterweight . . . . .								NS	BC
- 7	350997	† . Bushing . . . . .								4	BC
- 8	630261-27	. Pin, Damper, 4th Order . . . . .								2	BC
- 9	630261-3	. Pin, Damper, 5th Order . . . . .								2	BC
- 10	630261-4	. Pin, Damper, 6th Order . . . . .								4	BC
ATTACHING PARTS											
- 11	629105	. Plate, Pin Retaining . . . . .								16	BC
- 12	629104	. Ring, Retaining . . . . .								16	BC
* - - - -											
- 13	635439	\$† . Bearing, Crankshaft, Main . . . . .								10	BC
- 14	628136	\$† . Washer, Thrust . . . . .								4	BC
- 15	628750	† . Bearing, Connecting Rod . . . . .								6	BC
- 16	629680	Collar Assembly . . . . .								1	BC
	No Number	. Collar, 1-3-5 Side . . . . .								NS	BC
	No Number	. Collar, 2-4-6 Side . . . . .								NS	BC
- 17	626889	. Dowel . . . . .								2	BC
- 18	401893	† . Stud, 1/4 X 1-1/4 In. Lg. . . . .								2	BC
- 19	632443-4	. Nut, Marsden Lock . . . . .								2	BC
- 20	536563	Dowel, Crankshaft-to-Gear . . . . .								1	BC
- 21	632892	Gear, Crankshaft, Small . . . . .								1	BC
- 22	632893	Gear, Crankshaft, Large . . . . .								1	BC
ATTACHING PARTS											
- 23	X1454	Washer, Dowel Retainer . . . . .								1	BC
- 24	536379	Screw . . . . .								6	BC
* - - - -											
- 25	632018	Gear, Face Generator Drive . . . . .								1	BC
ATTACHING PARTS											
- 26	634080	Screw, 5/16-24 X 13/32 In. Lg. . . . .								4	BC
- 27	634021	Lock Plates . . . . .								2	BC
* - - - -											
- 28	626974	Seal Assembly, Crankshaft Oil . . . . .								1	BC
- 29	536615	Felt, Crankshaft Oil Seal . . . . .								1	BC
- 30	AN123962	\$ O-Ring . . . . .								1	BC
- 31	629360	Gear, Idler . . . . .								1	BC

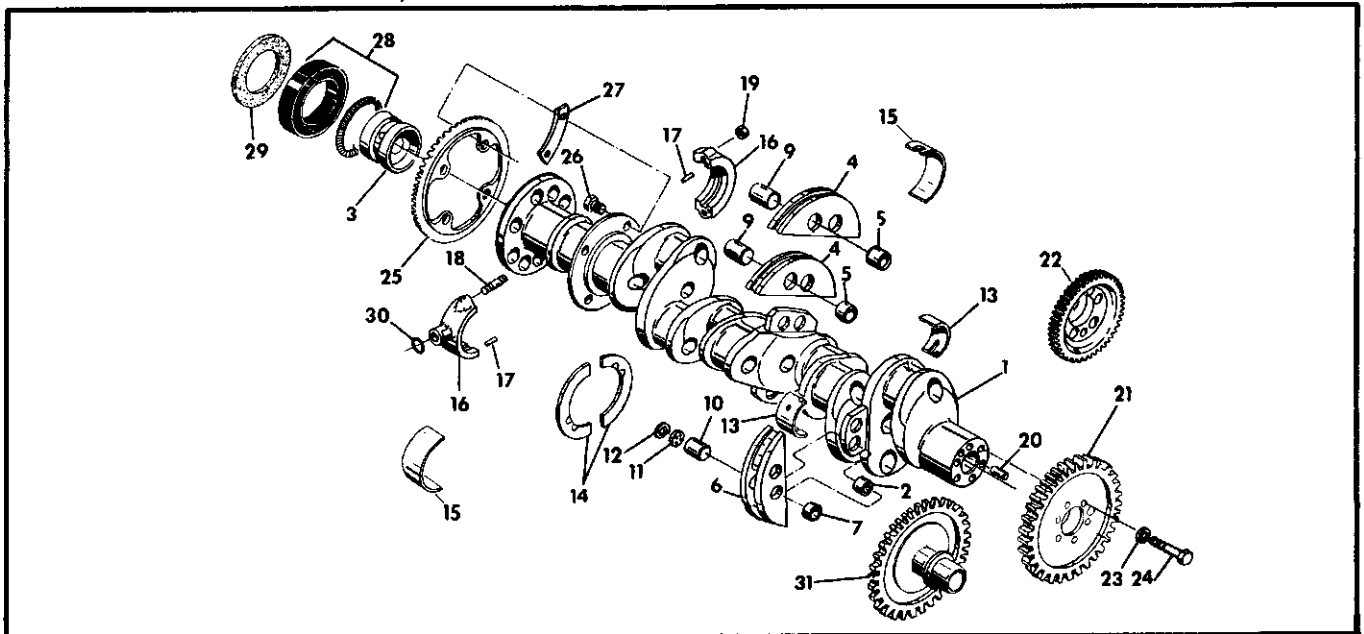

Figure 8. Crankshaft Group.



FIGURE & INDEX NO.	PART NUMBER	DESCRIPTION	UNITS PER ASS'Y.	USABLE ON CODE		
					1	2
9-	No Number	Camshaft Assembly . . . . .	NS	ADEFJKL		
- 1	535661	† . Camshaft . . . . .	1	ADEFJKL		
- 2	631845	. Gear, Camshaft . . . . .	1	ADEFJKL		
- 3	535662	. Gear, Cam Cluster . . . . .	1	ADEFJKL		
ATTACHING PARTS						
- 4	535666	. Screw, 5/16-24 X 25/32 In. Lg. . . . .	4	ADEFJKL		
		- - - * - - -				
- 5	AN280H405	. Key, Woodruff . . . . .	1	ADEFJKL		
- 6	534655	. Gear, Bevel Governor Drive . . . . .	1	ADEFJKL		
- 7	538076	. Gear, Bevel Governor Driven . . . . .	1	ADEFJKL		
	628488	Lifter Assembly, Hydraulic Valve . . . . .	12	ADEFJKL		
- 8	No Number	. Body, Valve Lifter . . . . .	NS	ADEFJKL		
- 9	No Number	. Spring, Plunger . . . . .	NS	ADEFJKL		
-10	No Number	. Housing, Check Valve . . . . .	NS	ADEFJKL		
-11	No Number	. Plate, Check Valve . . . . .	NS	ADEFJKL		
-12	No Number	. Plunger, Hydraulic Lifter . . . . .	NS	ADEFJKL		
-13	No Number	. Socket, Hydraulic Lifter . . . . .	NS	ADEFJKL		
-14	628491	. Ring, Retaining . . . . .	1	ADEFJKL		

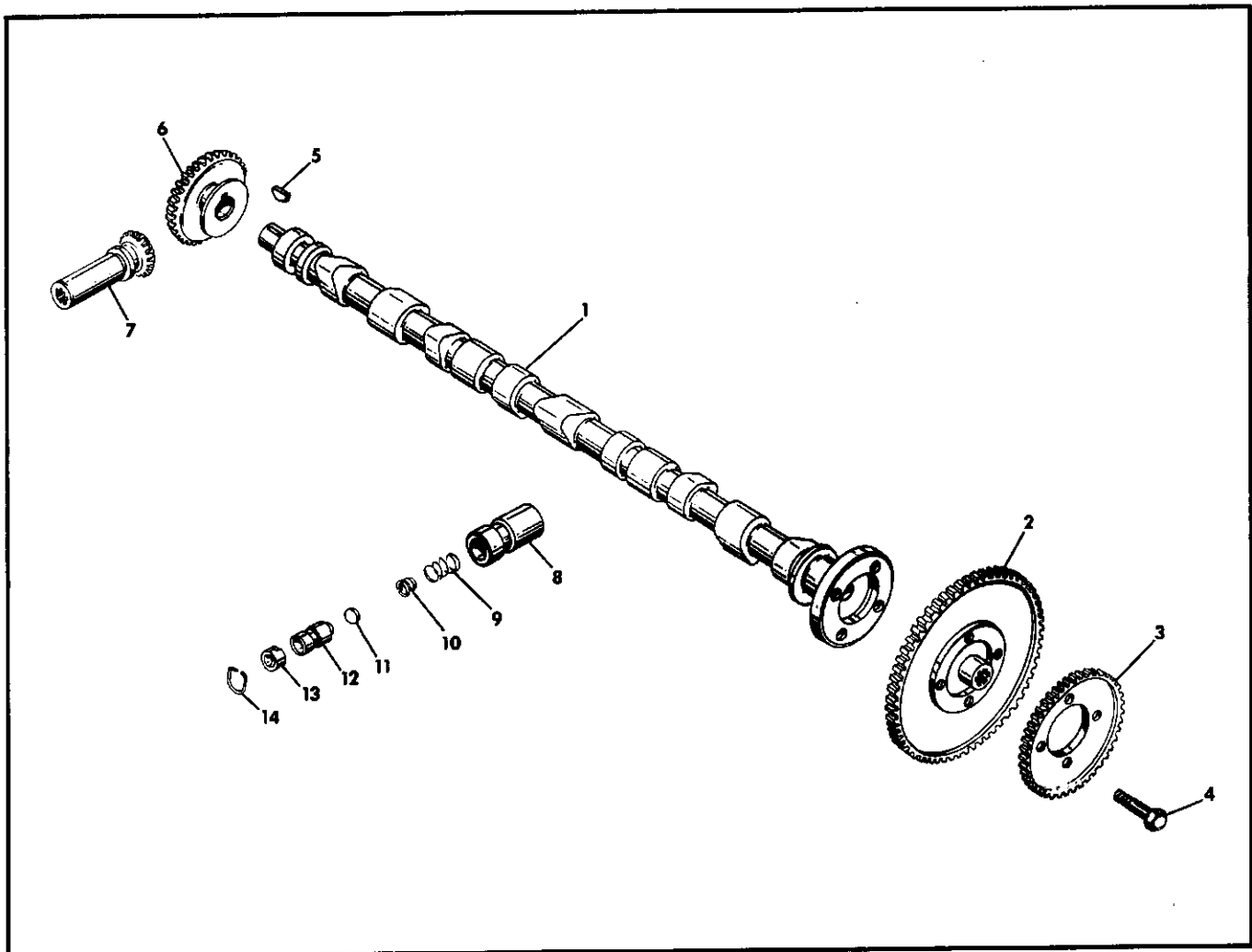

Figure 9. Camshaft Group.

FIGURE & INDEX NO.	PART NUMBER	DESCRIPTION							UNITS PER ASS'Y.	USABLE ON CODE
		1	2	3	4	5	6	7		
10-	No Number	Camshaft Assembly . . . . .							NS	BC
- 1	629726	†	. Camshaft . . . . .						1	BC
- 2	524818		. Plug, Pipe, 1/4-18 NPTF . . . . .						1	BC
- 3	631845		. Gear, Camshaft . . . . .						1	BC
ATTACHING PARTS										
- 4	631088-.44		. Screw, 5/16-24 X 7/16 In. Lg. . . . .						4	BC
* - - - -										
- 5	632092-4		. Plug, Expansion . . . . .						1	BC
- 6	AN280H405		. Key, Woodruff . . . . .						1	BC
- 7	629748		. Gear, Bevel, Governor Drive . . . . .						1	BC
- 8	629747		. Gear, Bevel, Governor Driven . . . . .						1	BC
	628488		Lifter Assembly, Hydraulic Valve . . . . .						12	BC
- 9	No Number		. Body, Valve Lifter . . . . .						NS	BC
-10	No Number		. Spring, Plunger . . . . .						NS	BC
-11	No Number		. Housing, Check Valve . . . . .						NS	BC
-12	No Number		. Plate, Check Valve . . . . .						NS	BC
-13	No Number		. Plunger, Hydraulic Lifter . . . . .						NS	BC
-14	No Number		. Socket, Hydraulic Lifter . . . . .						NS	BC
-15	628491		. Ring, Retaining . . . . .						1	BC

NOTE: Camshaft comes with plugs, items 2 & 5 not installed. They must be installed before the camshaft is assembled in the engine.

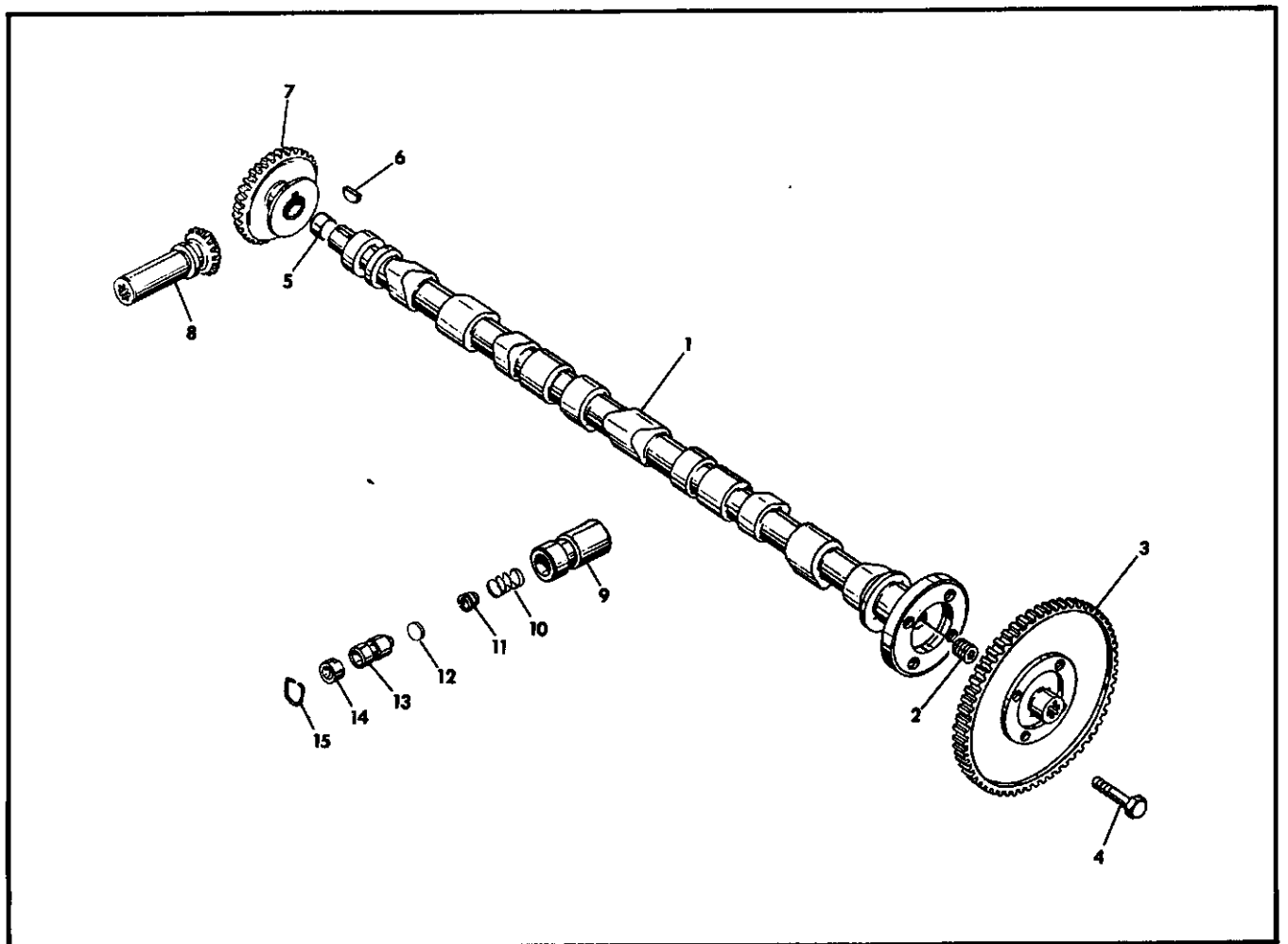

Figure 10. Camshaft Group.

FIGURE & INDEX NO.	PART NUMBER	DESCRIPTION	UNITS	USABLE
			PER ASS'Y.	ON CODE
		1 2 3 4 5 6 7		
11-	633403	* Connecting Rod Assembly, Complete . . . . .	6	All
- 1	No Number	. Rod, Connecting . . . . .	NS	All
- 2	No Number	. Cap, Connecting Rod . . . . .	NS	All
- 3	530658	. Bushing, Piston Pin . . . . .	1	All
- 4	629340	. Bolt, Connecting Rod . . . . .	2	All
- 5	628109	. Nut, 7/16-28, Slotted, Special . . . . .	2	All
- 6	AN381-25-10	. Pin, Cotter . . . . .	2	All

NOTE: (\*) Select rod assemblies for replacement to match weight of original assemblies in same engine. Maximum permissible weight variation in engine set = 1/4 ounce.

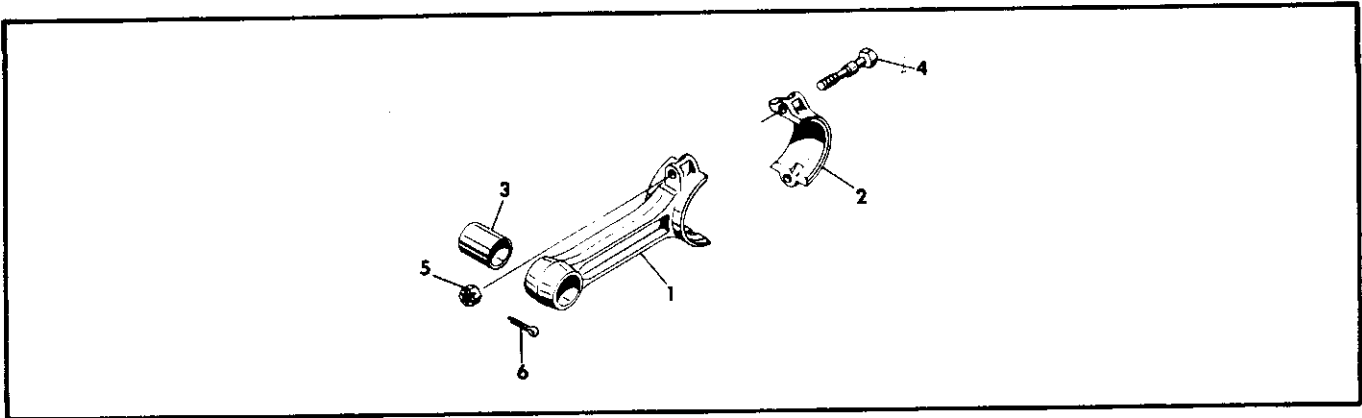

Figure 11. Connecting Rod Assembly.

FIGURE & INDEX NO.	PART NUMBER	DESCRIPTION	UNITS	USABLE
			PER ASS'Y.	ON CODE
		1 2 3 4 5 6 7		
12- 1	631475	*† Piston, 8.5:1 Compression Ratio . . . . .	6	All
- 2	630752	\$† Ring, Piston Compression - Top Groove - . . . . .	6	All
- 3	630753	\$† Ring, Piston Compression - 2nd Groove - . . . . .	6	All
- 4	631729	\$† Ring Assembly, Oil - 3rd Groove - . . . . .	6	All
- 5	629401	\$† Ring, Piston, Scraper - 4th Groove - . . . . .	6	All
- 6	630046	† Pin and Plug Assembly, Piston . . . . .	6	All

NOTE: (\*) Select pistons for replacement to match weight of original assemblies in same engine. Maximum permissible weight variation in engine set = 1/4 ounce.

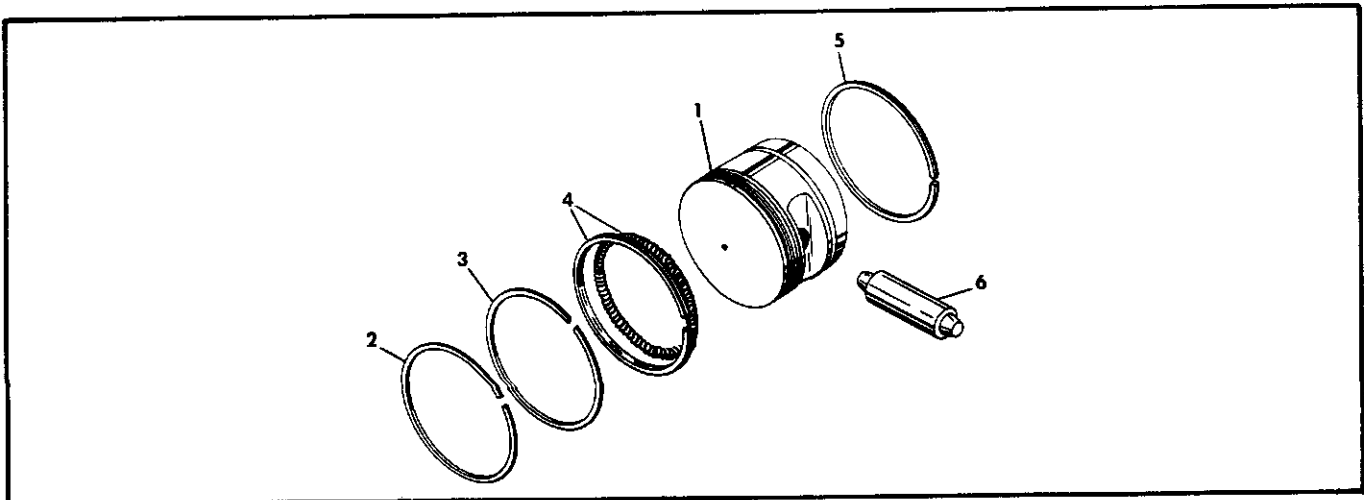

Figure 12. Piston and Pin Assembly.

FIGURE & INDEX NO.	PART NUMBER	DESCRIPTION	UNITS PER ASS'Y.							USABLE ON CODE
			1	2	3	4	5	6	7	
13- 1	631674	\$ Packing, Cylinder Base . . . . .							6	All
	No Number	Cylinder Assembly, Complete . . . . .							NS	All
ATTACHING PARTS										
- 2	531001	Nut, Flanged, 7/16-20 . . . . .							36	All
- 3	2958	Palnut, 7/16-20 . . . . .							36	All
- 4	538969	Nut, Flanged, 1/2-20 . . . . .							12	All
- 5	AN356-820	Palnut. . . . .							12	All
* - - - *										
	635448A1	. Cylinder & Valve Assembly . . . . .							6	All
	635448	. Cylinder Assembly . . . . .							1	All
- 6	No Number	. Head & Barrel Assembly . . . . .							NS	All
- 7	520112-1	. Insert, Spark Plug Thread. . . . .							2	All
- 8	631496	† . . . Guide, Valve. . . . .							2	All
- 9	401893	† . . . Stud, 1/4 X 1-1/4 In. Lg. . . . .							4	All
-10	MS122121	. . . Insert . . . . .							4	All
-11	630591	† . . . Insert, Intake Valve Seat . . . . .							1	All
-12	35967	† . . . Insert, Exhaust Valve Seat . . . . .							1	All
-13	539988	. Valve, Intake. . . . .							1	All
-14	635720	. Valve, Exhaust. . . . .							1	All
-15	631521	. Spring, Valve Inner. . . . .							2	All
-16	631520	. Spring, Valve Outer. . . . .							2	All
-17	625393	. Retainer, Valve Spring Inner. . . . .							2	All
-18	35971	. Retainer, Valve Spring Intake . . . . .							1	All
-19	629117	. Roto Cap Assembly, Exhaust . . . . .							1	All
-20	24802	. Key, Valve Spring Retainer . . . . .							4	All
-21	539740	. Shaft, Valve Rocker. . . . .							12	All
ATTACHING PARTS										
-22	2473	. Washer, Plain . . . . .							12	All
-23	537019	. Screw, 5/16-24 X 17/32 In. Lg. . . . .							12	All
* - - - *										

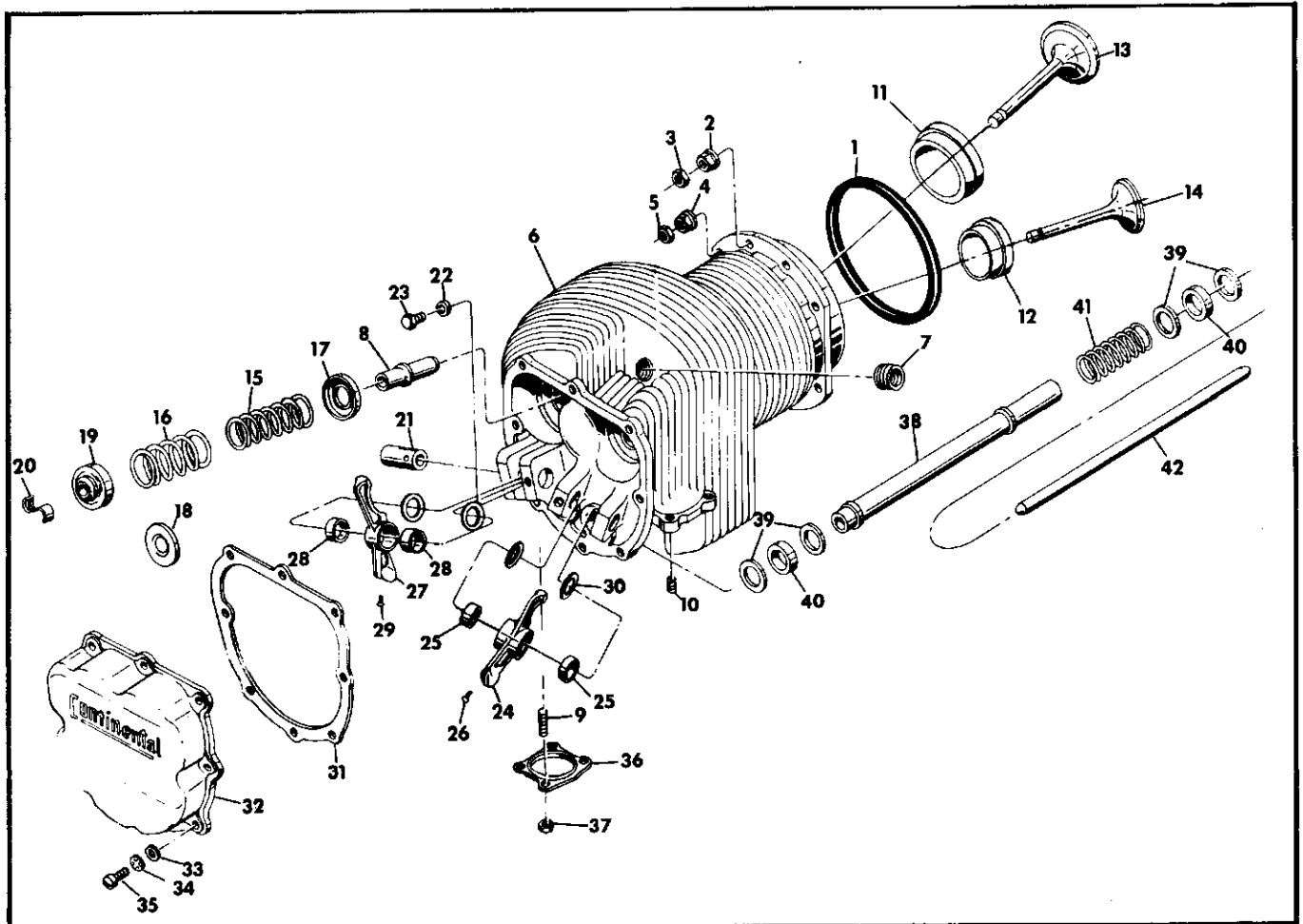

Figure 13. Cylinder Assembly.

FIGURE & INDEX NO.	PART NUMBER	DESCRIPTION	UNITS PER ASS'Y.							USABLE ON CODE
			1	2	3	4	5	6	7	
13-	539742	. Rocker Assembly, Intake Valve . . . . .							6	All
-24	No Number	. . Rocker, Intake Valve . . . . .							NS	All
-25	536033	. . Bushing, Valve Rocker . . . . .							2	All
-26	21007	. . Screw, Drive . . . . .							1	All
	534639	. Rocker Assembly, Exhaust Valve . . . . .							6	All
-27	No Number	. . Rocker, Exhaust Valve . . . . .							NS	All
-28	536033	. . Bushing, Valve Rocker . . . . .							2	All
-29	21007	. . Screw, Drive . . . . .							1	All
-30	534487	. Washer, Thrust . . . . .							24	All
-31	534857	. Gasket, Valve Rocker Cover. . . . .							6	All
-32	625615	. Cover, Valve Rocker . . . . .							6	All
ATTACHING PARTS										
-33	20522	. Washer, Plain . . . . .							48	All
-34	AN936A416	. Washer, Lock . . . . .							48	All
-35	535118	. Screw, Fillister Head. . . . .							48	All
* - - - -										
-36	537379	\$ Gasket, Exhaust Flange . . . . .							6	ACDEJKL
-36	631544	\$ Gasket, Exhaust Flange . . . . .							6	B
ATTACHING PARTS										
-37	21247	Nut, 1/4-28 Brass, Exhaust . . . . .							24	ABE
-37	536038	Nut, 1/4-28 CRES, Exhaust . . . . .							24	CDFJKL
* - - - -										
-38	537296	Housing, Push Rod . . . . .							12	All
-39	534609	Washer, Push Rod Housing . . . . .							48	All
-40	534610	\$ Packing, Push Rod Housing . . . . .							24	All
-41	626147	Spring, Push Rod Housing . . . . .							12	All
-42	538304	Push Rod Assembly. . . . .							12	All

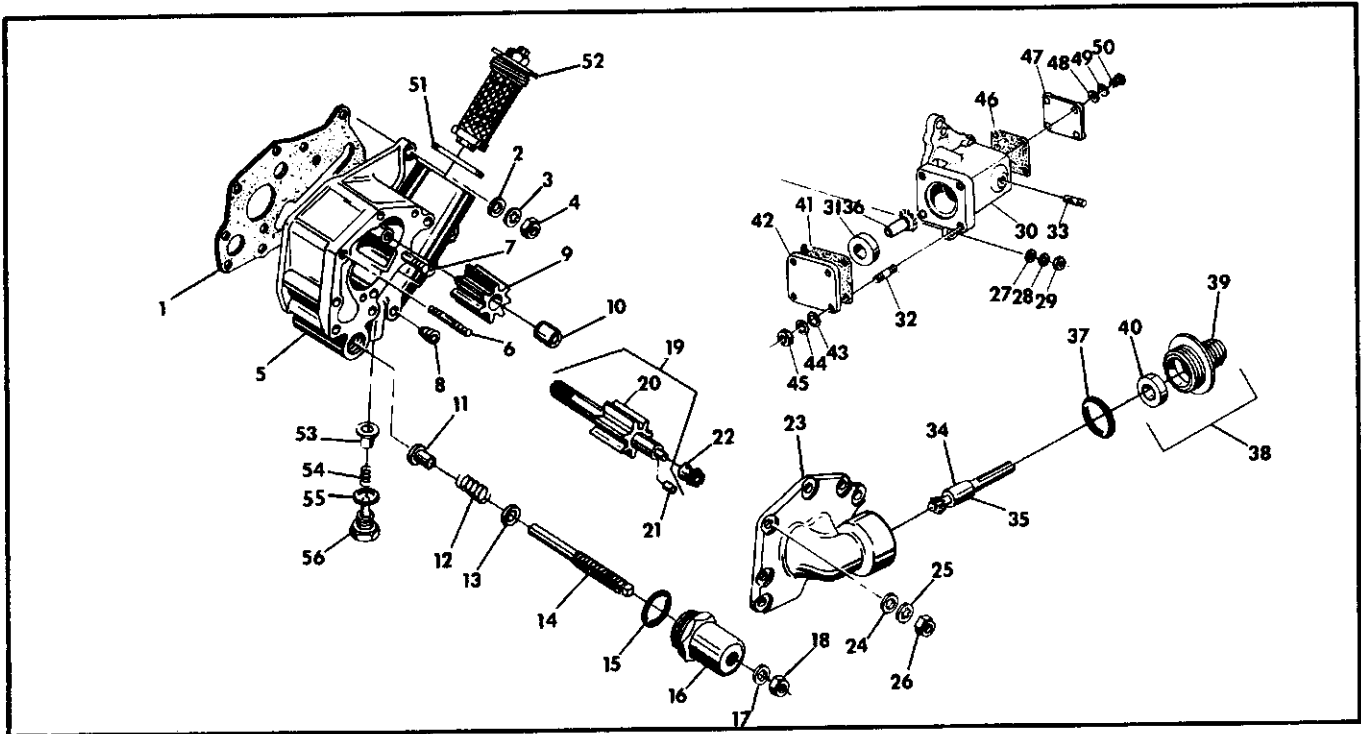

Figure 14. Oil Pump Assembly.

FIGURE & INDEX NO.	PART NUMBER	DESCRIPTION	UNITS PER ASS'Y.							USABLE ON CODE
			1	2	3	4	5	6	7	
14- 1	538185	\$ Gasket, Oil Pump Housing-to-Crankcase . . . . .							1	ADEFJKL
	631714A1	Housing Assembly, Oil Pump, Complete . . . . .							1	ADFJKL
	631714A2	Housing Assembly, Oil Pump, Complete . . . . .							1	E
ATTACHING PARTS										
- 2	20522	Washer, Plain . . . . .							7	ADEFJKL
- 3	AN936A416	Washer, Lock . . . . .							7	ADEFJKL
- 4	2437	Nut, Plain, Hex . . . . .							7	ADEFJKL
* - - - -										

FIGURE & INDEX NO.	PART NUMBER	DESCRIPTION	UNITS	USABLE
			PER ASS'Y.	ON CODE
		1 2 3 4 5 6 7		
14-	631714	. Housing & Shaft Assembly, Oil Pump . . . . .	1	ADEFJKL
- 5	No Number	. . . Housing, Oil Pump . . . . .	NS	ADEFJKL
- 6	401800	† . . Stud, 1/4 X 1-1/16 In. Lg. . . . .	1	ADEFJKL
- 7	401963	† . . Stud, 1/4 X 1 In. Lg. . . . .	1	ADEFJKL
- 8	2024	. . . Plug, Pipe . . . . .	1	ADEFJKL
	629218	. Gear & Bushing Assembly, Oil Pump, Driven . . . . .	1	ADEFJKL
- 9	No Number	. . . Gear, Oil Pump, Driven . . . . .	NS	ADEFJKL
-10	539523	. . . Bushing, Oil Pump Gear . . . . .	2	ADEFJKL
-11	631618	. . . Plunger, Oil Pressure Relief Valve . . . . .	1	ADEFJKL
-12	634150	. . . Spring, Oil Pressure Relief Valve . . . . .	1	ADEFJKL
-13	631653	. . . Washer, Spring Guide . . . . .	1	ADEFJKL
-14	632761	. . . Screw, Adjusting . . . . .	1	ADEFJKL
-15	AN900-18	\$ . . Gasket, Copper Asbestos Annular . . . . .	1	ADEFJKL
-16	633178	. . . Housing, Oil Pressure Relief Valve . . . . .	1	ADEFJKL
-17	X1473	. . . Washer, Copper . . . . .	1	ADEFJKL
-18	632762	. . . Nut, Adjusting . . . . .	1	ADEFJKL
-19	629448	. . . Shaftgear Assembly, Tach Drive, Oil Pump . . . . .	1	ADFJKL
-19	633442	. . . Shaftgear Assembly, Tach Drive . . . . .	1	E
-20	No Number	. . . Shaftgear, Tach Drive & Oil Pump . . . . .	NS	ADEFJKL
-21	535634	. . . Pin, Dowel . . . . .	1	ADEFJKL
-22	535008	. . . Gear, Bevel Tach Drive . . . . .	1	ADFJKL
-22	535900	. . . Gear, Bevel Tach Drive . . . . .	1	E
-23	625886	. . . Cover, Right Angle Tach Drive Oil Pump . . . . .	1	ADFJKL
ATTACHING PARTS				
-24	20522	. . . Washer, Plain . . . . .	6	ADFJKL
-25	AN936A416	. . . Washer, Lock . . . . .	6	ADFJKL
-26	2437	. . . Nut, Plain, Hex . . . . .	6	ADFJKL
- - - * - - -				
	628859	. . . Cover, Right Angle Tach Drive Oil Pump . . . . .	1	E
ATTACHING PARTS				
-27	20522	. . . Washer, Plain . . . . .	2	E
-28	AN936A416	. . . Washer, Lock . . . . .	2	E
-29	2437	. . . Nut, Plain, Hex . . . . .	2	E
- - - * - - -				
-30	No Number	. . . Cover . . . . .	NS	E
-31	531378	\$ . . Seal, Oil Tach Drive Cover . . . . .	1	E
-32	401893	† . . Stud, 1/4 X 1-1/4 In. Lg. . . . .	4	E
-33	401816	† . . Stud, 1/4 X 1-11/16 In. Lg. . . . .	1	E
-34	625885	. . . Shaftgear, Tach Drive . . . . .	1	AF
-35	631650	. . . Shaft Assembly, Tach Drive . . . . .	1	DJKL
-36	535908	. . . Gear Assembly, Bevel Tach Drive . . . . .	1	E
-37	632085	\$ . . Gasket, Cover Tach Housing . . . . .	1	ADFJKL
-38	21208A1	. . . Housing Assembly, Tach Drive . . . . .	1	ADFJKL
-39	No Number	. . . Housing, Tach Drive . . . . .	NS	ADFJKL
-40	21163	\$ . . Seal, Oil, Tach Housing . . . . .	1	ADFJKL
-41	AN4045-1	\$ . . Gasket . . . . .	1	E
-42	AN100043	. . . Cover, Tach Drive Pad . . . . .	1	E
ATTACHING PARTS				
-43	531547	. . . Washer, Plain . . . . .	4	E
-44	AN936A416	. . . Washer, Lock . . . . .	4	E
-45	AN315-4R	. . . Nut, Plain, Hex . . . . .	4	E
- - - * - - -				
-46	535885	\$ . . Gasket, Cover-to-Cover . . . . .	1	E
-47	535887	. . . Cover, Tach Gear Box . . . . .	1	E
ATTACHING PARTS				
-48	2471	. . . Washer, Plain . . . . .	4	E
-49	22910	. . . Washer, Lock . . . . .	4	E
-50	20655	. . . Screw . . . . .	4	E
- - - * - - -				
-51	AN900-28	\$ . . Gasket, Annular . . . . .	1	ADEFJKL
-52	538727	. . . Filter Assembly, Oil . . . . .	1	ADEFJKL
-53	631638	. . . Valve, Filter By-Pass . . . . .	1	ADEFJKL
-54	631478	. . . Spring, Filter By-Pass . . . . .	1	ADEFJKL
-55	AN900-14	\$ . . Gasket, Copper . . . . .	1	ADEFJKL
-56	631995	. . . Pin & Plug Assembly, Oil Pump By-Pass . . . . .	1	ADEFJKL

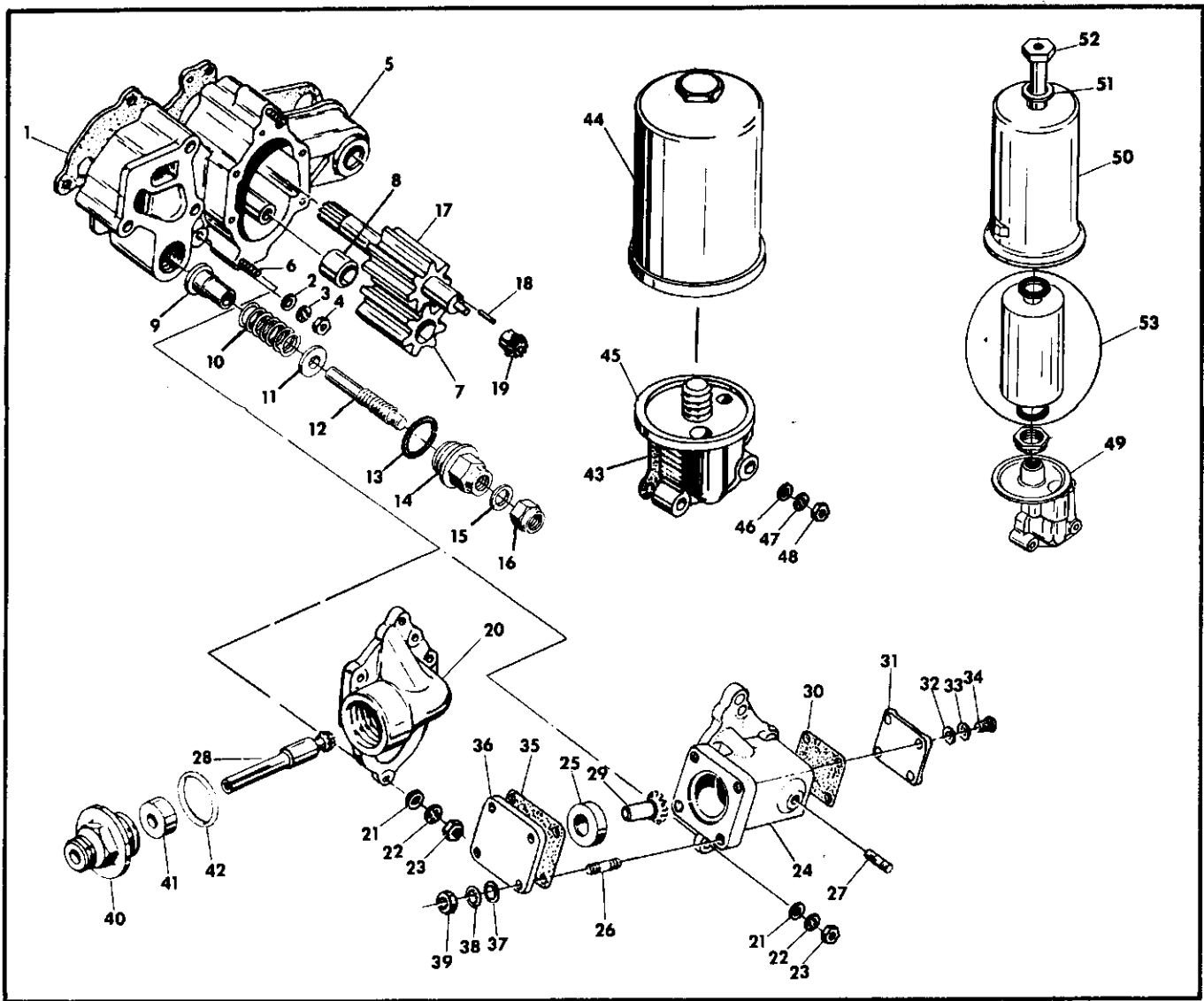

Figure 15. Oil Pump Assembly.

FIGURE & INDEX NO.	PART NUMBER	DESCRIPTION							UNITS PER ASS'Y.	USABLE ON CODE	
		1	2	3	4	5	6	7			
15- 1	631034	\$							1	BC	
	632977A1								1	B	
	632970								1	C	
			ATTACHING PARTS								
- 2	20522								1	BC	
- 3	AN936A416								1	BC	
- 4	2437								1	BC	
	632977								1	BC	
- 5	No Number								NS	BC	
- 6	401801	†							2	BC	
	631016								1	BC	
- 7	No Number								NS	BC	
- 8	23024								2	BC	
- 9	631618								1	BC	
-10	634150								1	BC	
-11	631653								1	BC	
-12	632761								1	BC	
-13	AN900-18	\$							2	BC	
-14	633178								1	BC	
-15	X1473								1	BC	
-16	632762								1	BC	

FIGURE & INDEX NO.	PART NUMBER	DESCRIPTION	UNITS PER ASS'Y.	USABLE ON CODE
	631014	. Shaftgear Assembly, Tach Drive . . . . .	1	B
	631075	. Shaftgear Assembly, Tach Drive . . . . .	1	C
-17	No Number	. . Shaftgear, Oil Pump & Tach Drive . . . . .	NS	BC
-18	535634	. Pin, Dowel . . . . .	1	BC
-19	535008	. Gear, Bevel, Tach Drive . . . . .	1	B
-19	535900	. Gear, Bevel, Tach Drive . . . . .	1	C
-20	631390	. Cover, Right Angle Tach Drive, Oil Pump. . . . .	1	B
	631056	. Cover Assembly, Right Angle Tach Drive, Oil Pump. . . . .	1	C
ATTACHING PARTS				
-21	20522	. Washer, Plain . . . . .	6	BC
-22	AN936A416	. Washer, Lock . . . . .	6	BC
-23	AN315-4R	. Nut, Plain, Hex . . . . .	6	BC
* - - - - *				
-24	No Number	. . Cover, Right Angle Drive, Oil Pump . . . . .	NS	C
-25	531378	\$ . . Seal, Oil . . . . .	1	C
-26	22319	† . . Stud, 1/4 X 1-1/4 In. Lg. . . . .	4	C
-27	402711	† . . Stud, 1/4 X 7/8 In. Lg. . . . .	1	C
-28	631650	. Shaft Assembly, Tach Drive . . . . .	1	B
-29	535908	. Shaftgear Assembly, Bevel Tach Drive . . . . .	1	C
-30	535885	\$ . Gasket, Cover-to-Cover. . . . .	1	C
-31	535887	. Cover, Tach Gear Box . . . . .	1	C
ATTACHING PARTS				
-32	2471	. Washer, Plain . . . . .	4	C
-33	22910	. Washer, Lock . . . . .	4	C
-34	20655	. Screw, Round Head, No. 10-24 X 1 In. Lg. . . . .	4	C
* - - - - *				
-35	AN4045-1	\$ . Gasket, Tach Drive Pad. . . . .	1	C
-36	AN100043	. Cover, Tach Drive Pad . . . . .	1	C
ATTACHING PARTS				
-37	531547	. Washer, Plain . . . . .	4	C
-38	AN936A416	. Washer, Lock . . . . .	4	C
-39	AN315-4R	. Nut, Plain, Hex . . . . .	4	C
* - - - - *				
	21208A1	. Housing, Tach Drive Assembly. . . . .	1	B
-40	No Number	. . Housing, Tach Drive . . . . .	NS	B
-41	21163	\$ . . Seal, Oil. . . . .	1	B
-42	AN900-22	\$ . Gasket, Annular . . . . .	1	B
-43	632266	\$ Gasket, Oil Filter-to-Pump Housing . . . . .	1	BC
-44	632399	Filter Assembly, Oil . . . . .	1	BC
-45	632881	Adapter Assembly, Oil Filter . . . . .	1	BC
ATTACHING PARTS				
-46	AN960-616L	Washer, Plain . . . . .	3	BC
-47	AN936A616	Washer, Lock . . . . .	3	BC
-48	2441	Nut, Plain, Hex . . . . .	3	BC
* - - - - *				
	631641	*Filter Assembly, Oil . . . . .	1	
-49	631645	* Adapter, Oil Filter . . . . .	1	
-50	631646	* Housing, Oil Filter . . . . .	1	
-51	631784	* Gasket, Copper . . . . .	1	
-52	631783	* Stud Assembly, Center . . . . .	1	
-53	632379	* Element, Oil Filter (Includes Gasket) . . . . .	1	

\* Parts so indicated were used on early models. If adapter (49) is serviceable, new element (53) may be ordered.



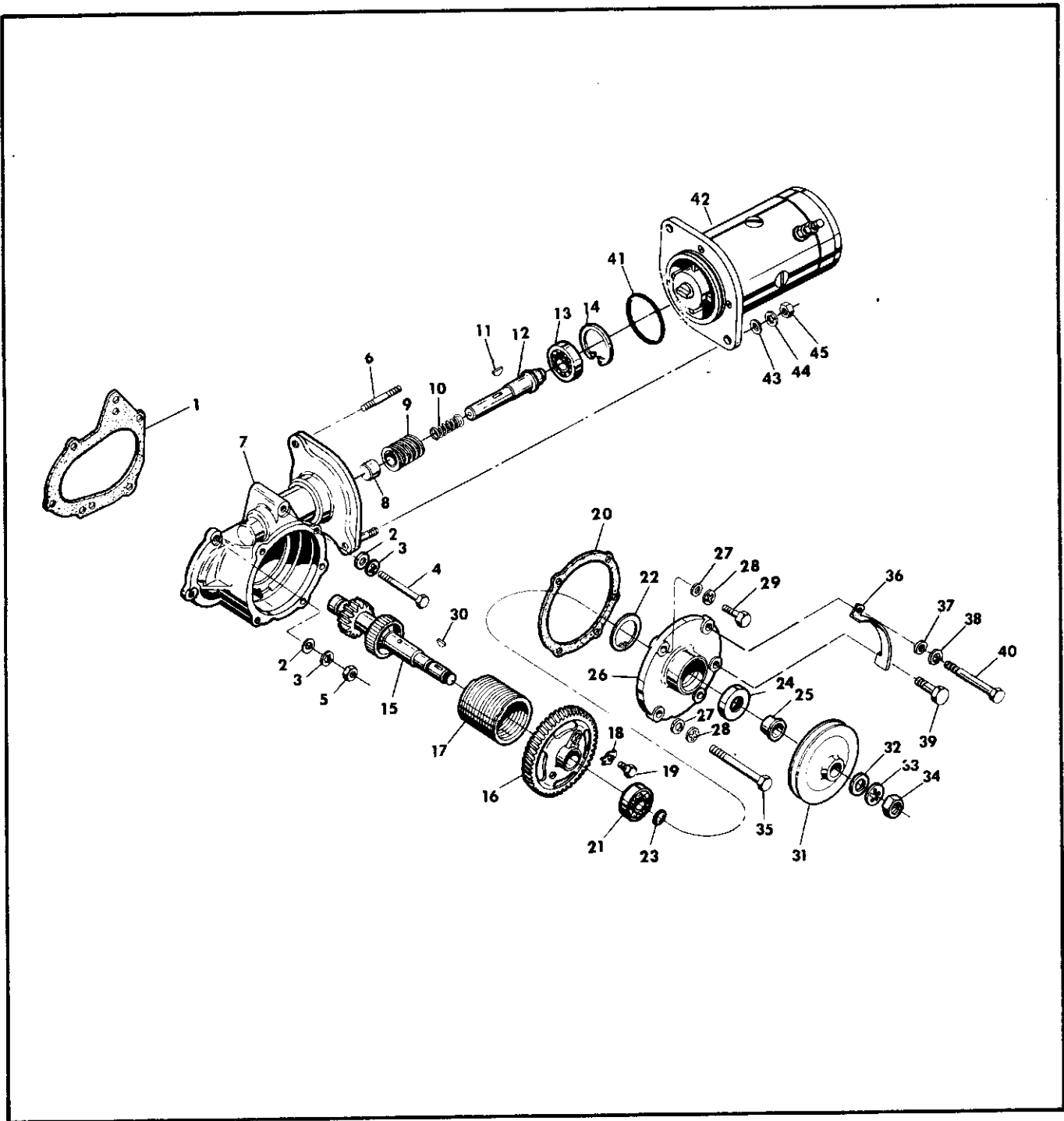

Figure 16. Starter and Starter Adapter Assembly.

FIGURE & INDEX NO.	PART NUMBER	DESCRIPTION	UNITS PER ASSY.	USABLE ON CODE
16- 1	537745 635050A4	\$ Gasket, Adapter-to-Crankcase . . . . . Adapter Assembly, Starter, Complete . . . . . ATTACHING PARTS	1 1	ADEFJKL ADEFJKL
- 2	2473	Washer, Plain . . . . .	3	ADEFJKL
- 3	AN936A516	Washer, Lock . . . . .	3	ADEFJKL
- 4	537742	Screw, 5/16-18 X 2-13/16 In. Lg. . . . .	1	ADEFJKL
- 5	AN315-5R	Nut, Plain . . . . .	2	ADEFJKL
		- - - * - - -		
	635050	. Adapter Assembly, Starter . . . . .	1	ADEFJKL
- 6	402127	† . Stud, 3/8-16 X 1-17/32 In. Lg. . . . .	2	ADEFJKL
- 7	No Number	. . Adapter & Sleeve Assembly . . . . .	NS	ADEFJKL
- 8	629713	. Bearing, Needle . . . . .	1	ADEFJKL
- 9	539805	. Gear, Starter, Worm . . . . .	1	ADEFJKL
-10	536552	. Spring, Starter . . . . .	1	ADEFJKL
-11	AN280H405	. Key, Woodruff . . . . .	1	ADEFJKL
-12	631252	. Shaft, Worm Drive . . . . .	1	ADEFJKL
-13	X13041	. Bearing, Ball . . . . .	1	ADEFJKL
-14	502287	. Ring, Retaining . . . . .	1	ADEFJKL
-15	539568	. Shaftgear, Starter . . . . .	1	ADEFJKL
-16	539785	. Gear, Starter Worm Wheel . . . . .	1	ADEFJKL
-17	539800	. Spring, Clutch . . . . .	1	ADEFJKL
		ATTACHING PARTS		
-18	501867	. Washer, Tab. . . . .	1	ADEFJKL
-19	633845	. Screw, 1/4-20 X 11/32 In. Lg. . . . .	1	ADEFJKL
		- - - * - - -		
-20	537749	\$ . Gasket, Cover-to-Adapter . . . . .	1	ADEFJKL
-21	534685	. Bearing, Ball . . . . .	1	ADEFJKL
-22	534715	. Ring, Retaining . . . . .	1	ADEFJKL
-23	AN123862	\$ . O-Ring . . . . .	1	ADEFJKL
-24	534938	\$ . Seal, Oil . . . . .	1	ADEFJKL
-25	534980	. Sleeve, Bearing Retainer . . . . .	1	ADEFJKL
-26	537738	. Cover, Starter Adapter . . . . .	1	ADEFJKL
		ATTACHING PARTS		
-27	2473	. Washer, Plain . . . . .	3	ADEFJKL
-28	AN936A516	. Washer, Lock . . . . .	3	ADEFJKL
-29	537750	. Screw, 5/16-18 X 1-1/8 In. Lg. . . . .	1	ADEFJKL
-30	AN280H405	. Key, Woodruff . . . . .	1	ADEFJKL
		- - - * - - -		
-31	534775	Sheave, Generator Drive . . . . .	1	ADEFJL
-31	635169	Sheave, Alternator Drive . . . . .	1	K
		ATTACHING PARTS		
-32	AN960C916	Washer, Plain . . . . .	1	ADEFJKL
-33	13XX299	Washer, Lock . . . . .	1	ADEFJKL
-34	AN316-9	Nut, Check . . . . .	1	ADEFJKL
		- - - * - - -		
-35	538999	Bolt, 5/16-18 X 3-5/8 In. Lg. . . . .	2	ADEFJKL
-36	628760	Indicator, Engine Timing . . . . .	1	ADEFJKL
		ATTACHING PARTS		
-37	2473	Washer, Plain . . . . .	2	ADEFJKL
-38	AN936A516	Washer, Lock . . . . .	2	ADEFJKL
-39	537750	Screw, 5/16-18 X 1-1/8 In. Lg. . . . .	1	ADEFJKL
-40	538999	Bolt, 5/16-18 X 3-5/8 In. Lg. . . . .	1	ADEFJKL
		- - - * - - -		
-41	MS9021-038	\$ O-Ring . . . . .	1	ADEFJKL
-42	629176	Starter, 12 Volt . . . . .	1	ADF
-42	627841	Starter, 24 Volt . . . . .	1	E
-42	634592	Starter, 12 Volt . . . . .	1	JKL
		ATTACHING PARTS		
-43	539058	Washer, Plain . . . . .	2	ADEFJKL
-44	AN936A616	Washer, Lock . . . . .	2	ADEFJKL
-45	AN315-6R	Nut, Plain, Hex . . . . .	2	ADEFJKL
		- - - * - - -		

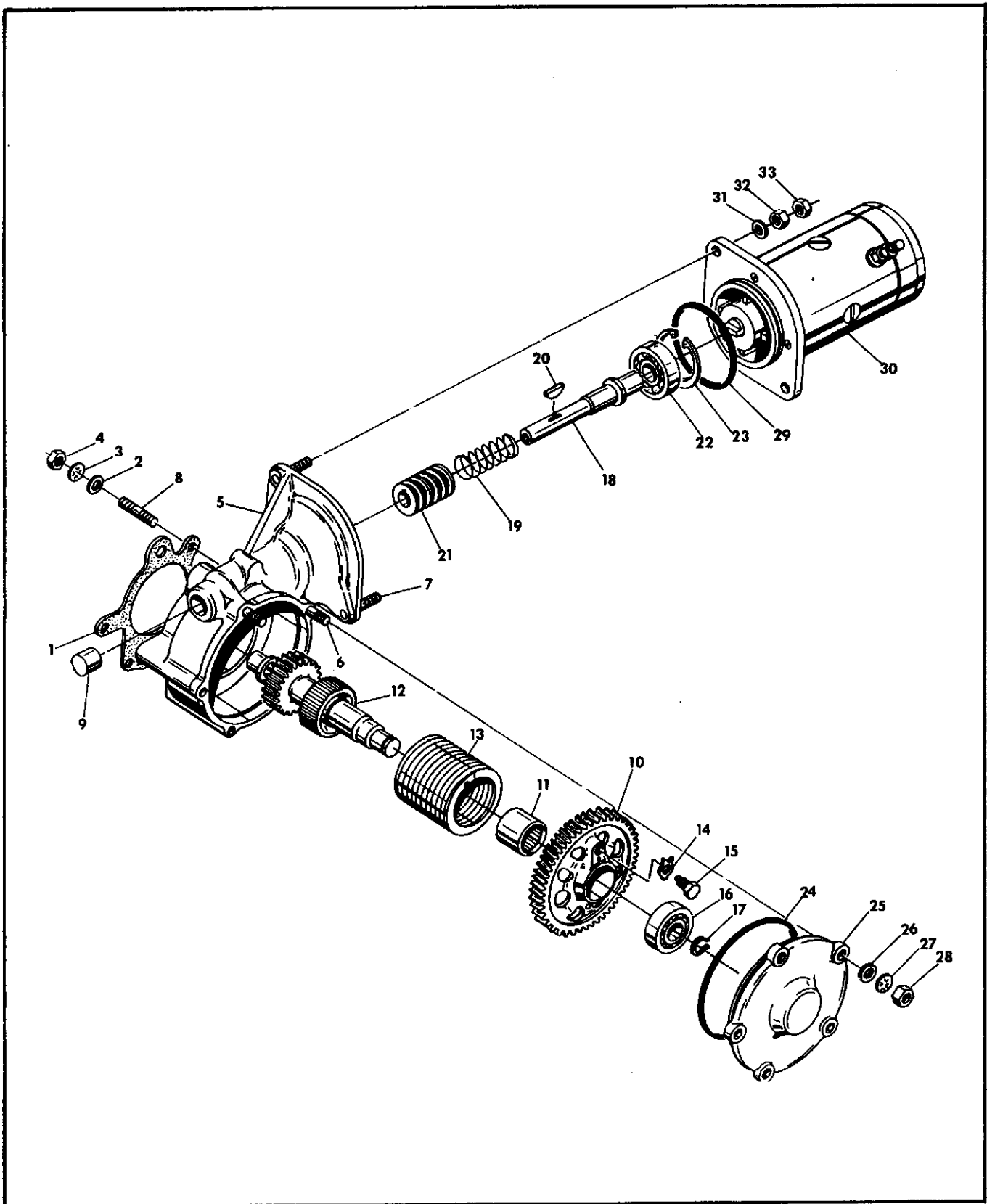

Figure 17. Starter and Starter Adapter Assembly.

FIGURE & INDEX NO.	PART NUMBER	DESCRIPTION	UNITS PER ASS'Y.	USABLE ON CODE
17- 1	630916	\$ Gasket, Adapter-to-Crankcase . . . . .	1	BC
	635049A1	Adapter Assembly, Starter, Complete . . . . .	1	BC
		ATTACHING PARTS		
- 2	2473	Washer, Plain . . . . .	2	BC
- 3	AN936A516	Washer, Lock . . . . .	2	BC
- 4	AN315-5R	Nut, Plain, Hex . . . . .	2	BC
		* - - - -		
	635049	. Adapter Assembly, Starter . . . . .	1	BC
- 5	No Number	. . Adapter & Sleeve Assembly . . . . .	NS	BC
- 6	402151	† . . Stud, 5/16 X 1-1/4 In. Lg. . . . .	3	BC
- 7	402127	† . . Stud, 3/8 X 1-17/32 In. Lg. . . . .	2	BC
- 8	402131	† . . Stud, 5/16 X 1-1/2 In. Lg. . . . .	2	BC
- 9	629713	. Bearing, Needle . . . . .	1	BC
	630681	. Gear Assembly, Starter Worm . . . . .	1	BC
-10	No Number	. . Gear, Starter Worm . . . . .	NS	BC
-11	630680	. . Bearing, Needle . . . . .	1	BC
-12	630895	. Shaftgear Assembly, Starter . . . . .	1	BC
-13	539800	. Spring, Clutch . . . . .	1	BC
		ATTACHING PARTS		
-14	501867	. Washer, Tab. . . . .	1	BC
-15	633845	. Screw, 1/4-20 X 11/32 In. Lg. . . . .	1	BC
		* - - - -		
-16	534685	. Bearing, Ball . . . . .	1	BC
-17	521649	. Ring, Retaining. . . . .	1	BC
-18	631252	. Shaft, Worm Drive . . . . .	1	BC
-19	536552	. Spring, Starter Worm Gear . . . . .	1	BC
-20	AN280H405	. Key, Woodruff . . . . .	1	BC
-21	539805	. Gear, Starter Worm . . . . .	1	BC
-22	X13041	. Bearing, Ball . . . . .	1	BC
-23	502287	. Ring, Retaining . . . . .	1	BC
-24	AN123902	\$ . O-Ring . . . . .	1	BC
-25	629668	. Cover, Starter Adapter . . . . .	1	BC
		ATTACHING PARTS		
-26	2473	. Washer, Plain . . . . .	5	BC
-27	AN936A516	. Washer, Lock . . . . .	5	BC
-28	AN315-5R	. Nut, Plain, Hex . . . . .	5	BC
		* - - - -		
-29	MS9021-038	\$ O-Ring . . . . .	1	BC
-30	629176	Motor, 12 Volt, Starter . . . . .	1	B
-30	627841	Motor, 24 Volt, Starter . . . . .	1	C
		ATTACHING PARTS		
-31	401507	Washer, Plain . . . . .	2	BC
-32	2441	Nut, Plain, Hex . . . . .	2	BC
-33	2561	Palnut. . . . .	2	BC
		* - - - -		

FIGURE & INDEX NO.	PART NUMBER	DESCRIPTION	UNITS PER ASS'Y.							USABLE ON CODE	
			1	2	3	4	5	6	7		
18- 1	539547-31, 19	Belt, Generator Driven . . . . .								1	A
- 2	536213	Spacer, Generator Driven . . . . .								1	A
- 3	627377	Sheave, Generator Driven . . . . .								1	A
- 4	627272	Generator, 12 Volt, 50 Amp . . . . .								1	A
ATTACHING PARTS											
- 5	AN5-20A	Bolt . . . . .								1	A
- 6	AN5-15A	Bolt . . . . .								2	A
- 7	2473	Washer, Plain . . . . .								2	A
- 8	AN315-5R	Nut, Plain, Hex . . . . .								2	A
- 9	2560	Palnut . . . . .								2	A
-10	AN75A6	Bolt . . . . .								1	A
-11	537539	Washer, Plain . . . . .								1	A
* - - - - *											
-12	627673	Idler, Kiss . . . . .								1	A
ATTACHING PARTS											
-13	22661	Nut, Self Locking, 1/4-28 . . . . .								1	A
* - - - - *											
-14	627276	Bracket, Generator Adjusting Arm . . . . .								1	A
-15	AN75A15	Screw . . . . .								1	A
-16	627279	Washer, Special . . . . .								6	A
-17	627281	Bushing, Spacer . . . . .								3	A
-18	627282	Bushing, Rubber . . . . .								6	A
-19	627068	Bracket, Generator Support . . . . .								1	A
-20	632112	Bracket Assembly, Kiss Idler . . . . .								1	A
-21	627690	Bracket, Generator Mounting . . . . .								RF	A

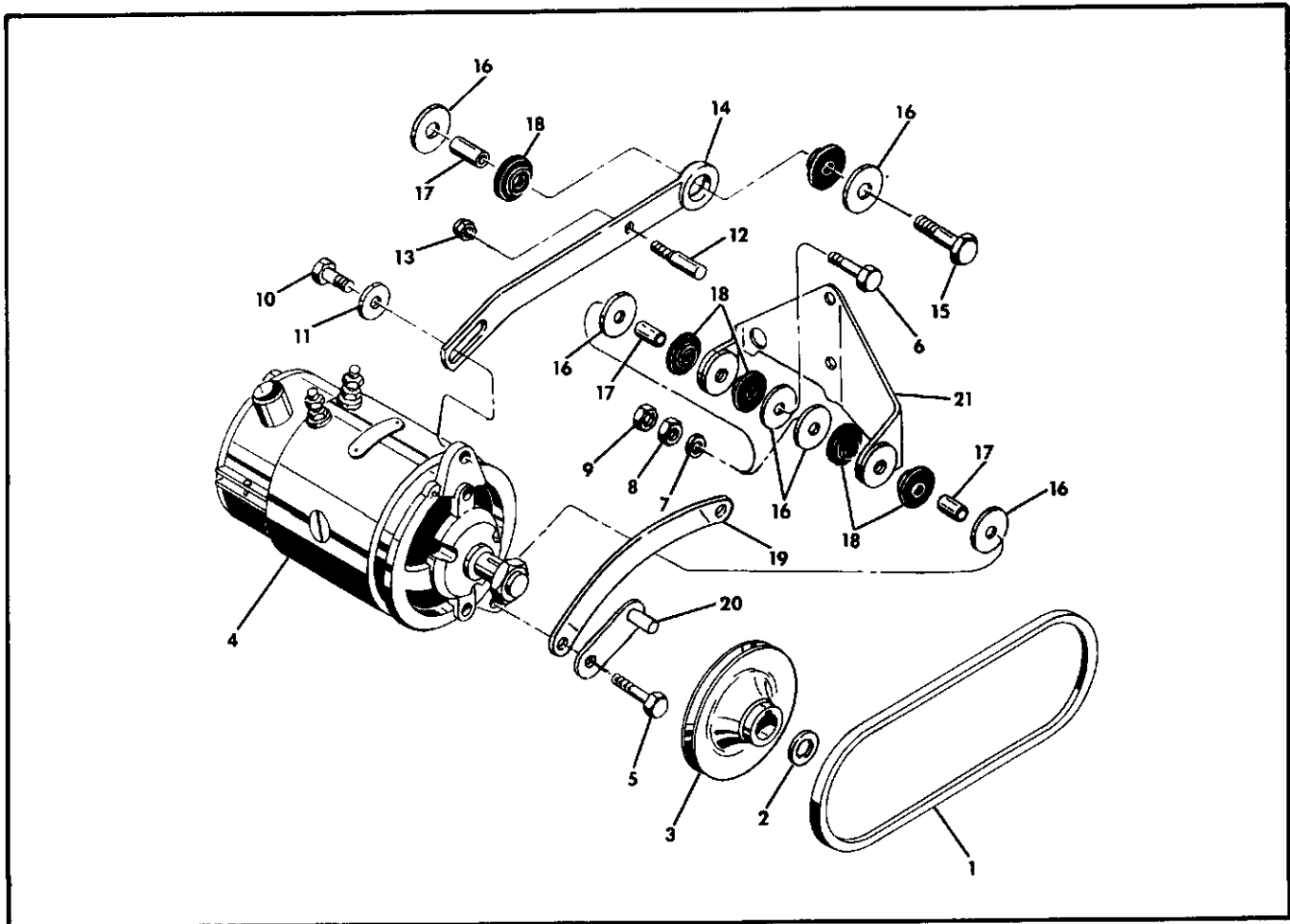

Figure 18. Generator Assembly.

FIGURE & INDEX NO.	PART NUMBER	DESCRIPTION	UNITS PER ASS'Y.							USABLE ON CODE	
			1	2	3	4	5	6	7		
19- 1	629436	\$ Gasket . . . . .								1	BC
	No Number	Alternator Assembly, Complete . . . . .								NS	B
	No Number	Alternator Assembly, Complete . . . . .								NS	C
		ATTACHING PARTS									
- 2	2473	Washer, Plain . . . . .								4	BC
- 3	628730	Bolt, 5/16-18 X 1 In. Lg. . . . .								4	BC
		* - - - - *									
- 4	631547	. Alternator, 12 Volt, 70 Amp. . . . .								1	B
- 4	632590	. Alternator, 24 Volt, 50 Amp. . . . .								1	C
- 5	632437	. Key, Woodruff . . . . .								1	BC
- 6	632436	. Nut, Slotted Hex, 5/8-32 UN-2A Thread. . . . .								1	BC
	631121	. Hub Assembly, Alternator Gear Driven . . . . .								1	BC
- 7	No Number	. Hub, Alternator Gear Driven . . . . .								NS	BC
- 8	630655	. Spring, Clutch . . . . .								1	BC
	630590	. Gear Assembly, Alternator Driven . . . . .								1	BC
- 9	No Number	. Gear & Washer, Alternator Driven . . . . .								NS	BC
-10	629638	. Bushing, Alternator Driven . . . . .								1	BC
-11	630691	. Washer, Thrust . . . . .								1	BC
-12	MS24665-302	. Pin, Cotter . . . . .								1	BC
-13	632125	Support Assembly, Baffle . . . . .								1	BC

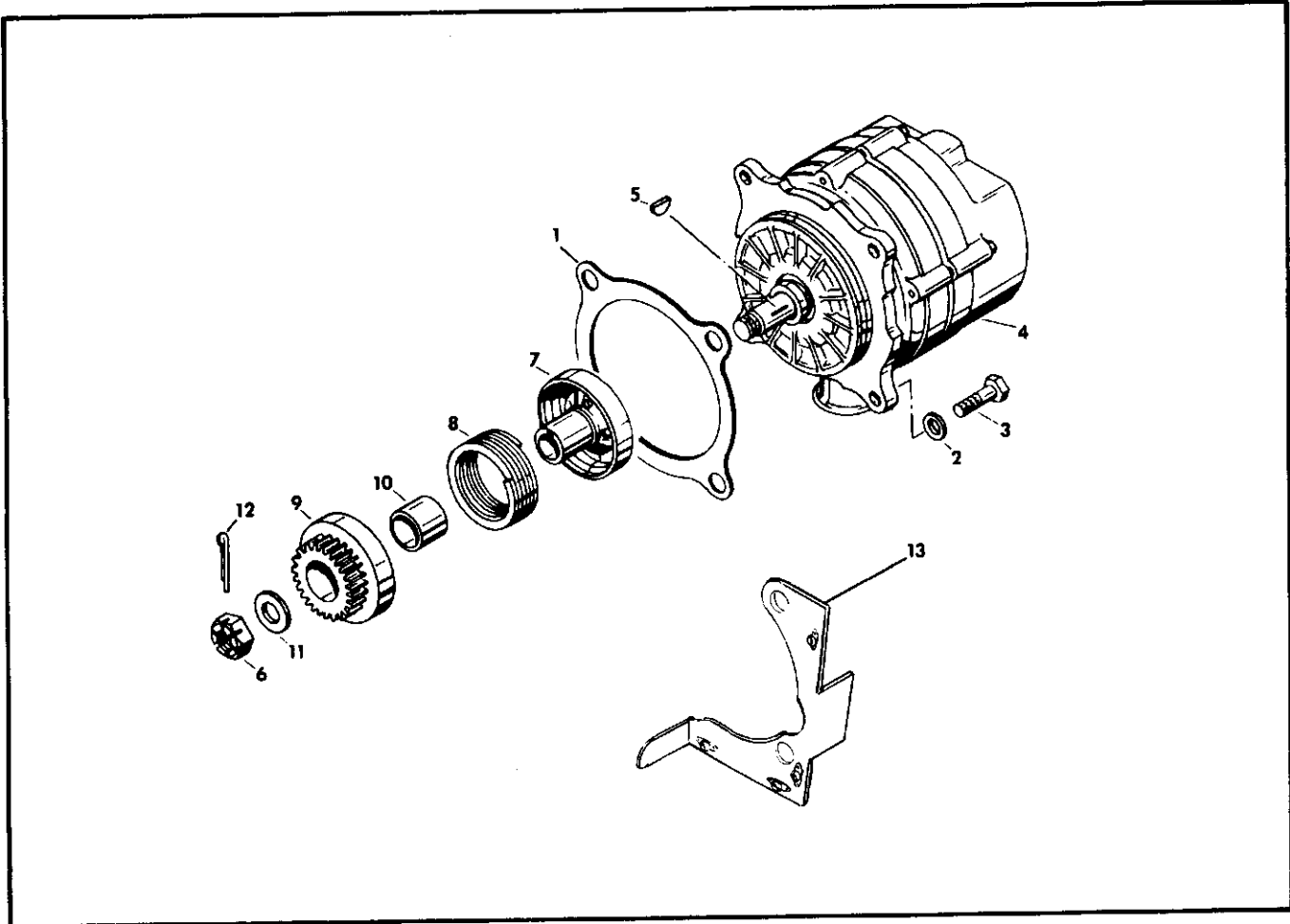

Figure 19. Alternator Assembly.

FIGURE & INDEX NO.	PART NUMBER	DESCRIPTION	1 2 3 4 5 6 7							UNITS PER ASS'Y.	USABLE ON CODE
20- 1	539547-32.00	Belt, Generator Driven . . . . .								1	E
- 2	536213	Spacer, Generator Driven . . . . .								1	E
- 3	627377	Sheave, Generator Driven . . . . .								1	E
- 4	629417	Generator, 24 Volt, 50 Amp . . . . .								1	E
ATTACHING PARTS											
- 5	AN5-17A	Bolt, 5/16-24 X 1-31/32 In. Lg. . . . .								1	E
- 6	AN5-15A	Bolt, 5/16-24 X 1-23/32 In. Lg. . . . .								1	E
- 7	2555	Washer, Plain . . . . .								1	E
- 8	2473	Washer, Plain . . . . .								1	E
- 9	AN315-5R	Nut, Plain, Hex . . . . .								2	E
-10	2560	Palnut . . . . .								2	E
-11	AN75A6	Bolt, 5/16-18 X 51/64 In. Lg. . . . .								1	E
-12	537539	Washer, Plain . . . . .								1	E
* - - - - *											
-13	627673-2	Pin, Idler Kiss . . . . .								1	E
-14	22661	Nut, Elastic Stop . . . . .								1	E
-15	629825	Bracket Assembly, Generator Belt Adj., Upper . . . . .								1	E
-16	AN75A10	Bolt, 5/16-18 X 1-3/64 In. Lg. . . . .								1	E
-17	627279	Washer, Special . . . . .								4	E
-18	627281	Bushing . . . . .								2	E
-19	627282	Bushing . . . . .								4	E
-20	630039	Bracket Assembly, Generator Belt Adj., Upper . . . . .								1	E
-21	628004	Bracket, Generator, Mounting . . . . .								1	E

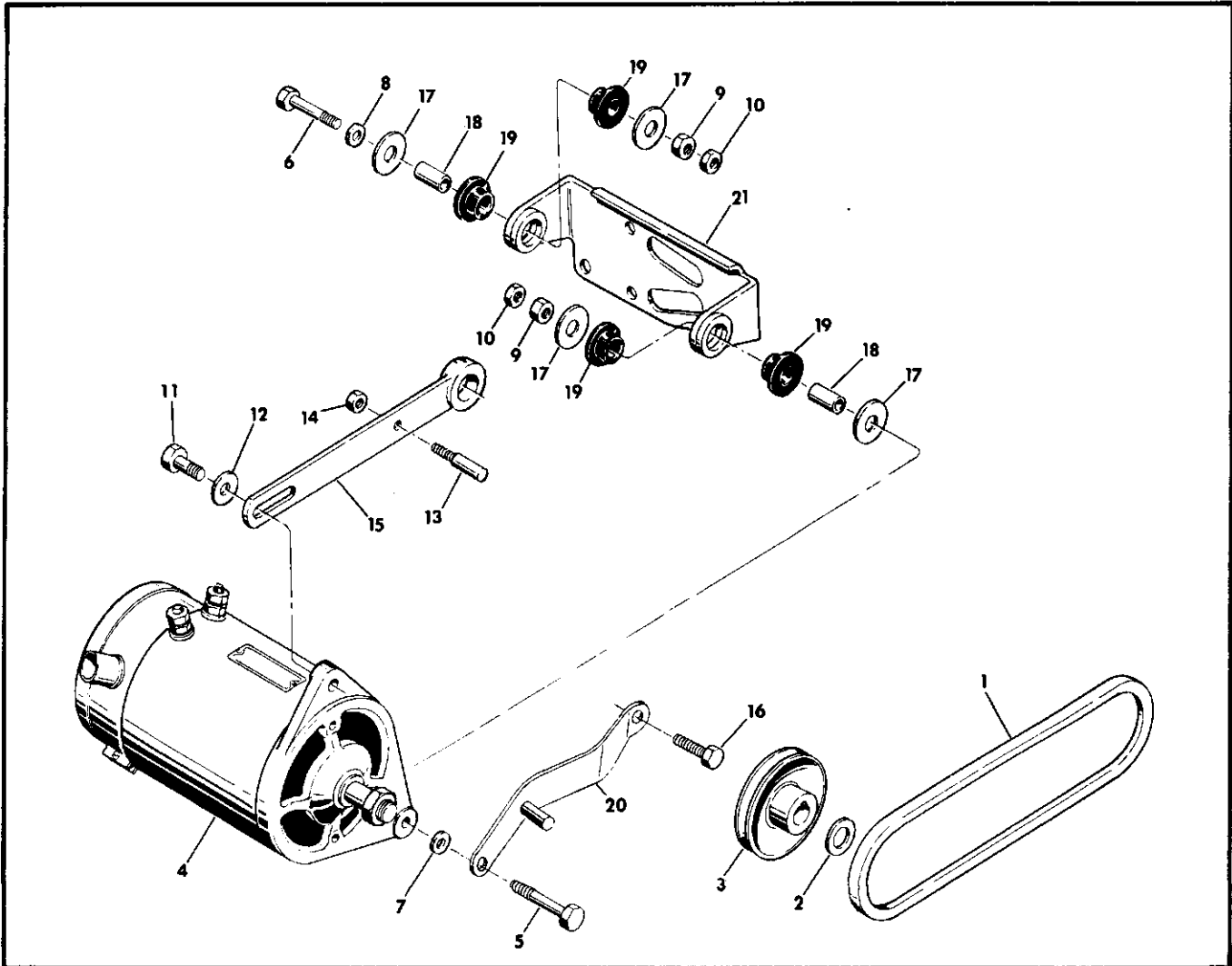

Figure 20. Generator Assembly.

FIGURE & INDEX NO.	PART NUMBER	DESCRIPTION	1 2 3 4 5 6 7							UNITS PER ASSY.	USABLE ON CODE
21- 1	634693	Alternator . . . . .								1	K
- 2	630691	Lockwasher . . . . .								1	K
- 3	632436	Nut . . . . .								1	K
- 4	632437	Key . . . . .								1	K
ATTACHING PARTS											
- 5	2561	Palnut . . . . .								1	K
- 6	2441	Nut . . . . .								1	K
- 7	22786	Washer . . . . .								2	K
- 8	24239	Washer . . . . .								2	K
- 9	634657	Bolt . . . . .								1	K
- - - * - - -											
-10	634571	Sheave . . . . .								1	K
-11	634617	Bracket . . . . .								1	K
ATTACHING PARTS											
-12	530346	Screw . . . . .								1	K
-13	13XX202B	Lockwasher . . . . .								1	K
-14	537539	Washer . . . . .								2	K
-15	537750	Screw . . . . .								1	K
-16	501868	Washer, Tab . . . . .								1	K
- - - * - - -											
-17	539547-32.00	Belt, 32 In. Lg. . . . .								1	K

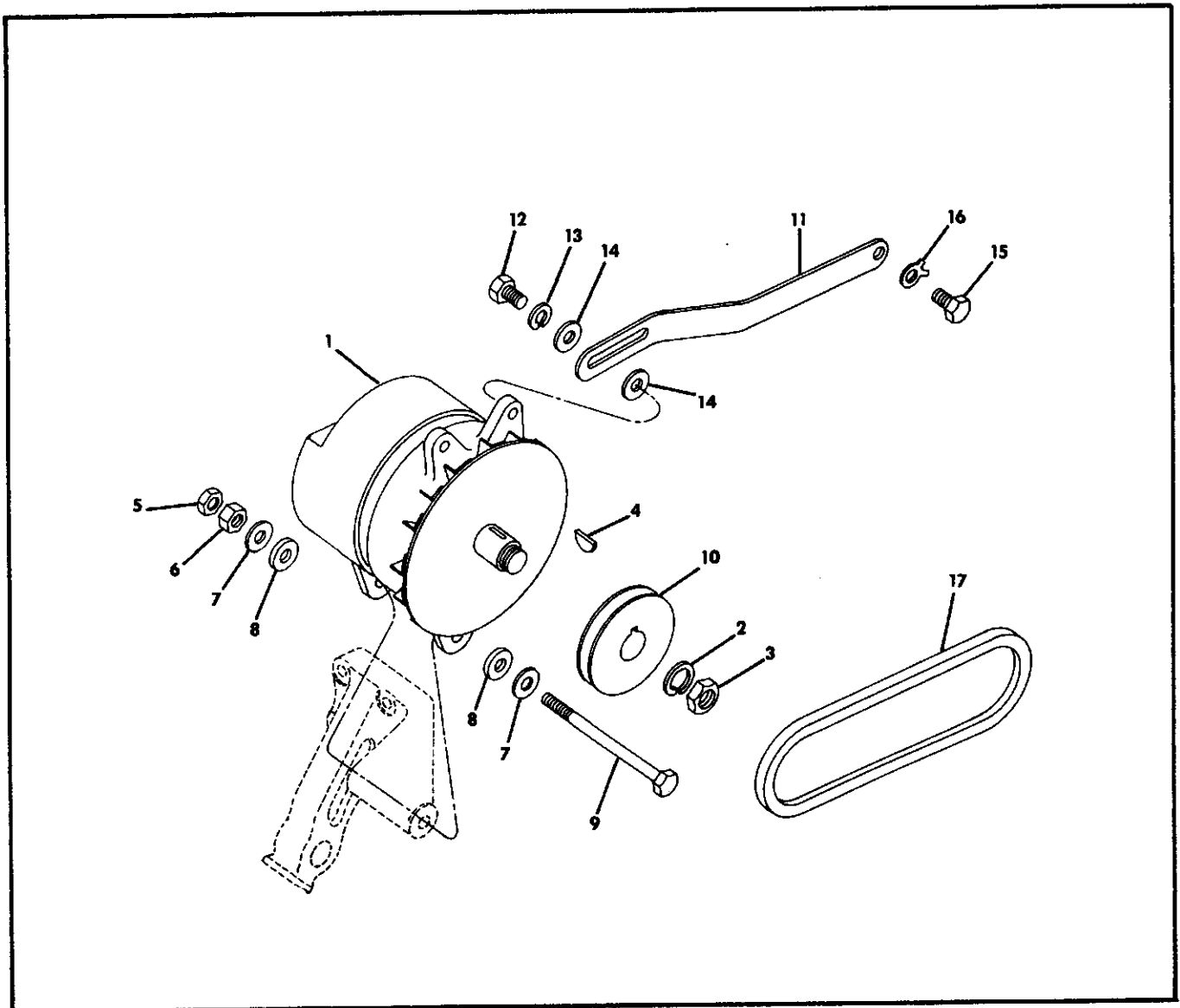

Figure 21. Alternator Assembly



FIGURE & INDEX NO.	PART NUMBER	DESCRIPTION	UNITS PER ASS'Y.							USABLE ON CODE	
			1	2	3	4	5	6	7		
22- 1	625303	\$ Gasket, Crankcase-to-Plate . . . . .								1	ADEFJKL
- 2	537312	Plate, Oil Cooler Adapter . . . . .								1	ADEFJKL
ATTACHING PARTS											
- 3	20522	Washer, Plain . . . . .								5	ADEFJKL
- 4	AN936A416	Washer, Lock . . . . .								5	ADEFJKL
- 5	2437	Nut, Plain, Hex . . . . .								5	ADEF
* - - - -											
- 6	2026	Plug, Pipe, 1/4-18 . . . . .								1	ADEFJKL
- 7	537282	\$ Gasket, Oil Cooler . . . . .								1	ADEFJKL
- 8	626189A	Cooler Assembly, Oil. . . . .								1	ADEFJKL
ATTACHING PARTS											
- 9	2473	Washer, Plain . . . . .								12	ADEF
-10	AN936A416	Washer, Lock . . . . .								12	ADEFJKL
-11	535631	Screw, 1/4-20 X 1 In. Lg. . . . .								12	ADEFJKL
- - - * - - -											
-12	632823	Bracket, Oil Cooler Support . . . . .								1	ADEFJKL
-13	632824	Bracket, Oil Cooler Support . . . . .								1	ADEFJKL
-14	629806	Bolt, Special Off Set Head . . . . .								1	ADEFJKL
-15	536779	Washer, Drain . . . . .								1	ADEFJKL
-16	2437	Nut, Plain, Hex . . . . .								1	ADEF
-17	2886	Palnut, 1/4 . . . . .								1	ADEFJKL

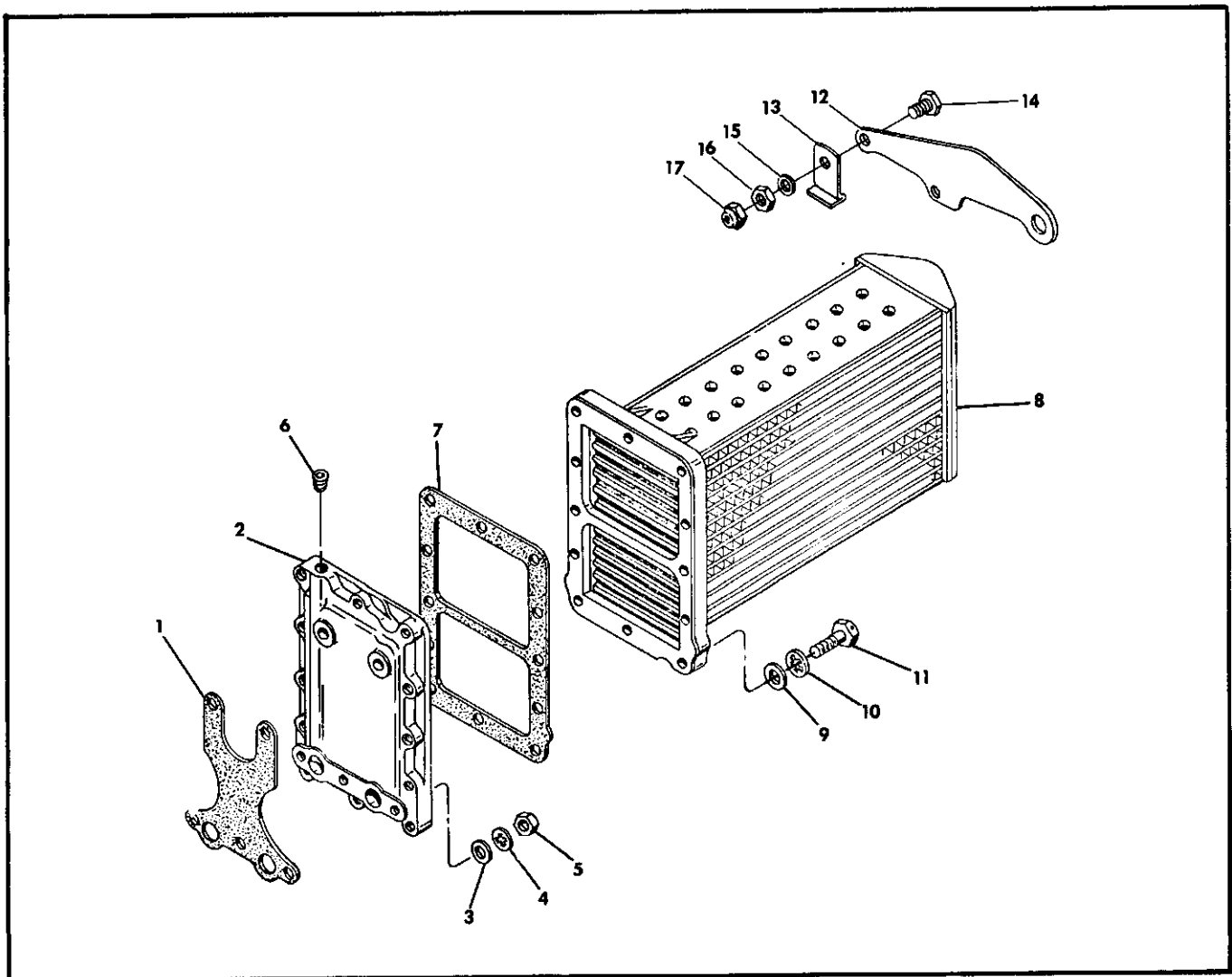

Figure 22. Oil Cooler.

FIGURE & INDEX NO.	PART NUMBER	DESCRIPTION	UNITS	USABLE
			PER ASSY.	ON CODE
23- 1	630849	\$ Gasket, Oil Cooler-to-Crankcase, Top . . . . .	2	B
- 2	631059	\$ Gasket, Crankcase-to-Oil Cooler. . . . .	1	B
- 3	MS9021-017	\$ O-Ring, Oil Cooler-to-Engine Mounting Bracket . . . . .	2	C
	633287	Oil Cooler & Baffle Assembly . . . . .	1	B
	633288 —	Oil Cooler & Baffle Assembly . . . . .	1	C
ATTACHING PARTS				
- 4	2474	Washer, Plain . . . . .	4	BC
- 5	AN936A616	Washer, Lock . . . . .	4	BC
- 6	2441	Nut, Plain, Hex . . . . .	4	BC
- 7	2473	Washer, Plain . . . . .	1	B
- 8	AN936A516	Washer, Lock . . . . .	1	B
- 9	AN315-5R	Nut, Plain, Hex . . . . .	1	B
		* — — —		
-10	634063	. Cooler, Oil . . . . .	1	BC
-11	632224	. Baffle, Oil Cooler . . . . .	1	B
-11	632276	. Baffle, Oil Cooler . . . . .	1	C
-12	634628	Elbow, 90 Degree, 1/8 NPTF to 1/8 Tube. . . . .	1	B
-12	631658	Elbow, 90 Degree, 1/8 NPTF to 1/4 Tube. . . . .	1	C
-13	626972-1	Closure, 1/8 Tube . . . . .	1	BC
-14	2025	Plug, Oil Cooler Oil Outlet . . . . .	1	C
-15	634065	Valve Assembly, Vernatherm Control . . . . .	1	BC
-16	632126	Support Assembly, Baffle . . . . .	1	BC

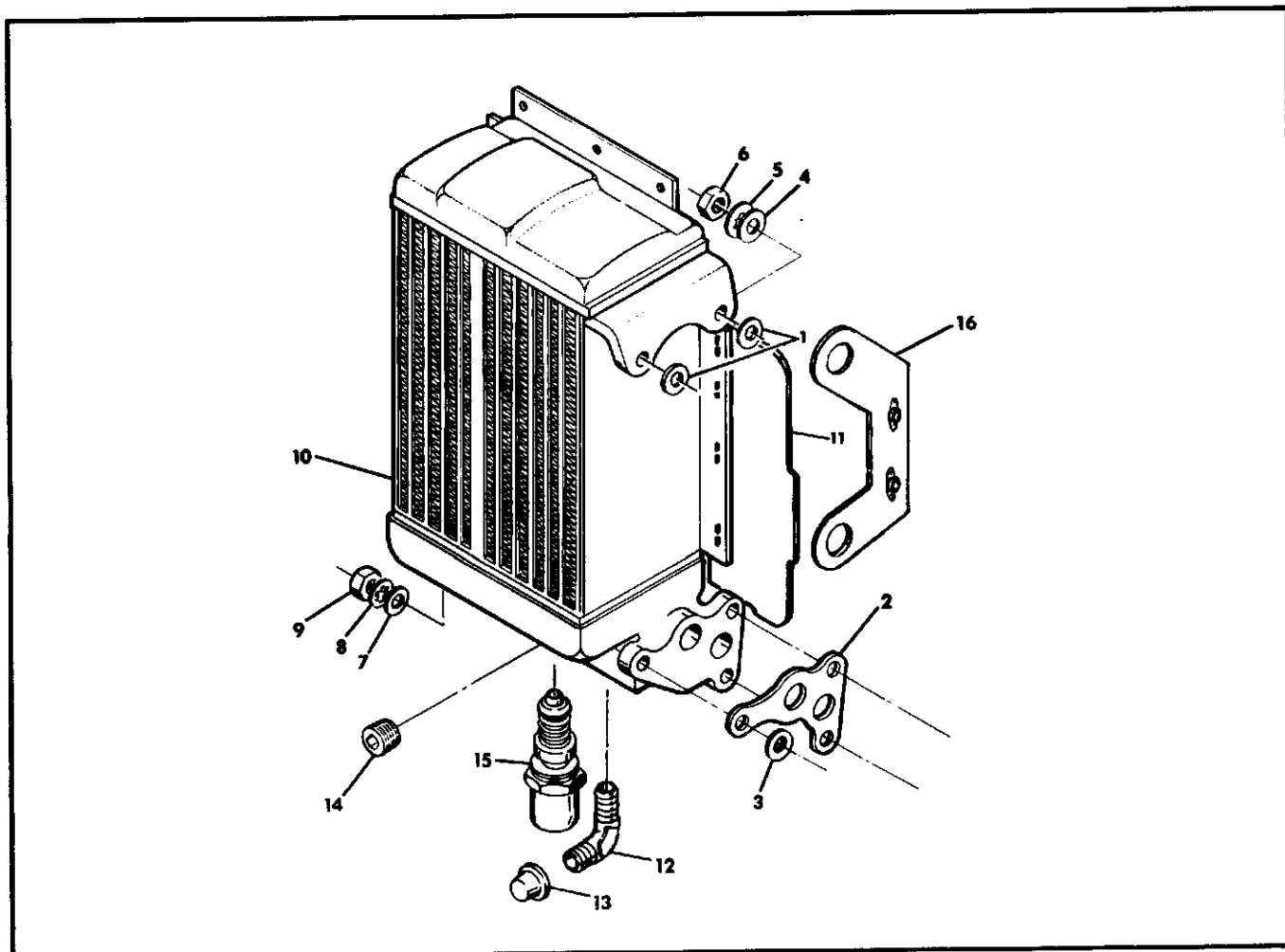

Figure 23. Oil Cooler.

FIGURE & INDEX NO.	PART NUMBER	DESCRIPTION	UNITS PER ASSY.							USABLE ON CODE	
			1	2	3	4	5	6	7		
24- 1	534940	\$ Gasket, Suction Tube Assembly . . . . .								1	ADEFK
- 2	625207	Tube Assembly, Suction, Oil Pump. . . . .								1	ADEFK
		ATTACHING PARTS									
- 3	20522	Washer, Plain . . . . .								2	ADEFK
- 4	AN74A4	Bolt. . . . .								2	ADEFK
- 5	AN74A3	Bolt. . . . .								2	ADEFK
		-----*									
- 6	632946	Tube Assembly, Suction, Oil Pump. . . . .								1	C
		ATTACHING PARTS									
- 7	631367	Washer, Special . . . . .								1	C
- 8	AN4-17A	Bolt. . . . .								1	C
		-----*									
- 9	AN900-10	\$ Gasket, Annular . . . . .								1	C
-10	AN900-12	\$ Gasket, Annular . . . . .								1	C
-11	2265	Plug, Hex Head . . . . .								1	C
-12	534743	\$ Gasket, Oil Sump. . . . .								1	ACDEFK
-13	633412	Sump Assembly, Oil . . . . .								1	AF
-13	537650	Sump Assembly, Oil . . . . .								1	CDK
-13	628698A1	Sump Assembly, Oil . . . . .								1	E
		ATTACHING PARTS									
-14	2473	Washer, Plain . . . . .								28	ACDEFK
-15	13XX202B	Washer, Lock . . . . .								28	ACDEFK
-16	530346	Screw, 5/16-18 X 7/8 In. Lg. . . . .								28	ACDEFK
		-----*									
-17	AN900-10	\$ . Gasket, Annular . . . . .								1	AEF
-17	AN900-10	\$ . Gasket, Annular . . . . .								2	CDK
-18	532432	. Plug, Oil Drain. . . . .								1	AEF
-18	532432	. Plug, Oil Drain. . . . .								2	CDK

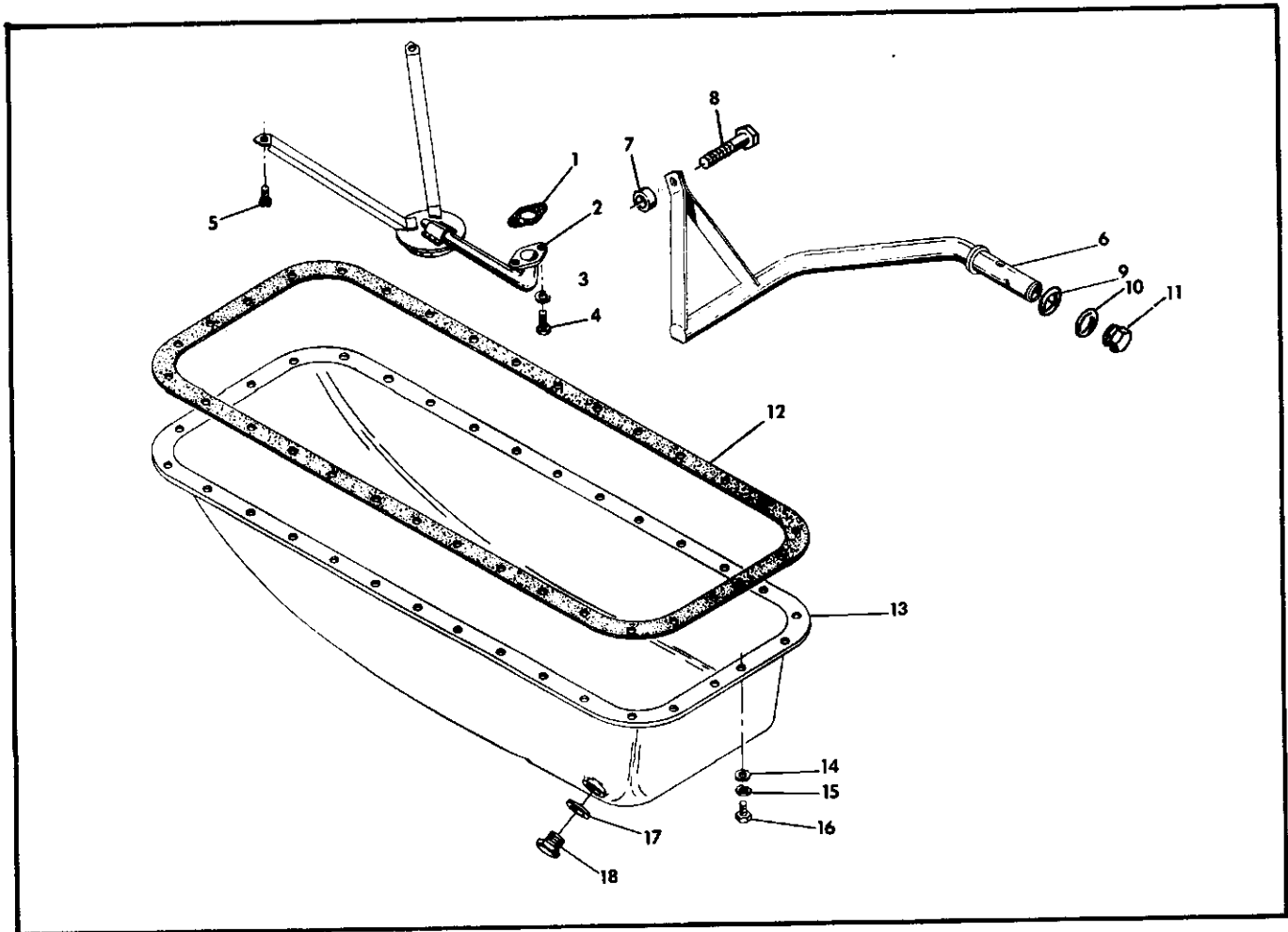

Figure 24. Oil Sump.

FIGURE & INDEX NO.	PART NUMBER	DESCRIPTION	UNITS PER ASS'Y.							USABLE ON CODE	
			1	2	3	4	5	6	7		
25- 1	631008	Tube Assembly, Suction, Oil Pump. . . . .								1	B
		ATTACHING PARTS									
- 2	630966-.56	Bolt, 5/16-18 X 9/16 In. Lg. . . . .								2	B
		* - - - -									
- 3	AN900-12	\$ Gasket, Annular . . . . .								1	B
- 4	2265	Plug. . . . .								1	B
- 5	534743	\$ Gasket, Oil Sump. . . . .								1	B
	628372A4	Studding Assembly, Sump . . . . .								1	B
		ATTACHING PARTS									
- 6	2473	Washer, Plain . . . . .								30	B
- 7	13XX202B	Washer, Lock . . . . .								30	B
- 8	537750	Bolt, 5/16-18 X 1-1/8 In. Lg. . . . .								30	B
		* - - - -									
- 9	401860	† . Stud, 3/8 X 1-9/16 In. Lg. . . . .								12	B
-10	628372A2	. Sump, Oil . . . . .								1	B
-11	AN900-10	\$ . Gasket, Annular . . . . .								2	B
-12	2265	. Plug, Oil Drain . . . . .								1	B
-13	534625	Felt, 3-1/16 X 4-1/16 . . . . .								1	B
-14	632663	Bracket, Engine Mount . . . . .								4	B
		ATTACHING PARTS									
-15	AN960-616L	Washer, Plain . . . . .								12	B
-16	AN936A616	Washer, Lock . . . . .								12	B
-17	2441	Nut, Plain, Hex . . . . .								12	B
		* - - - -									

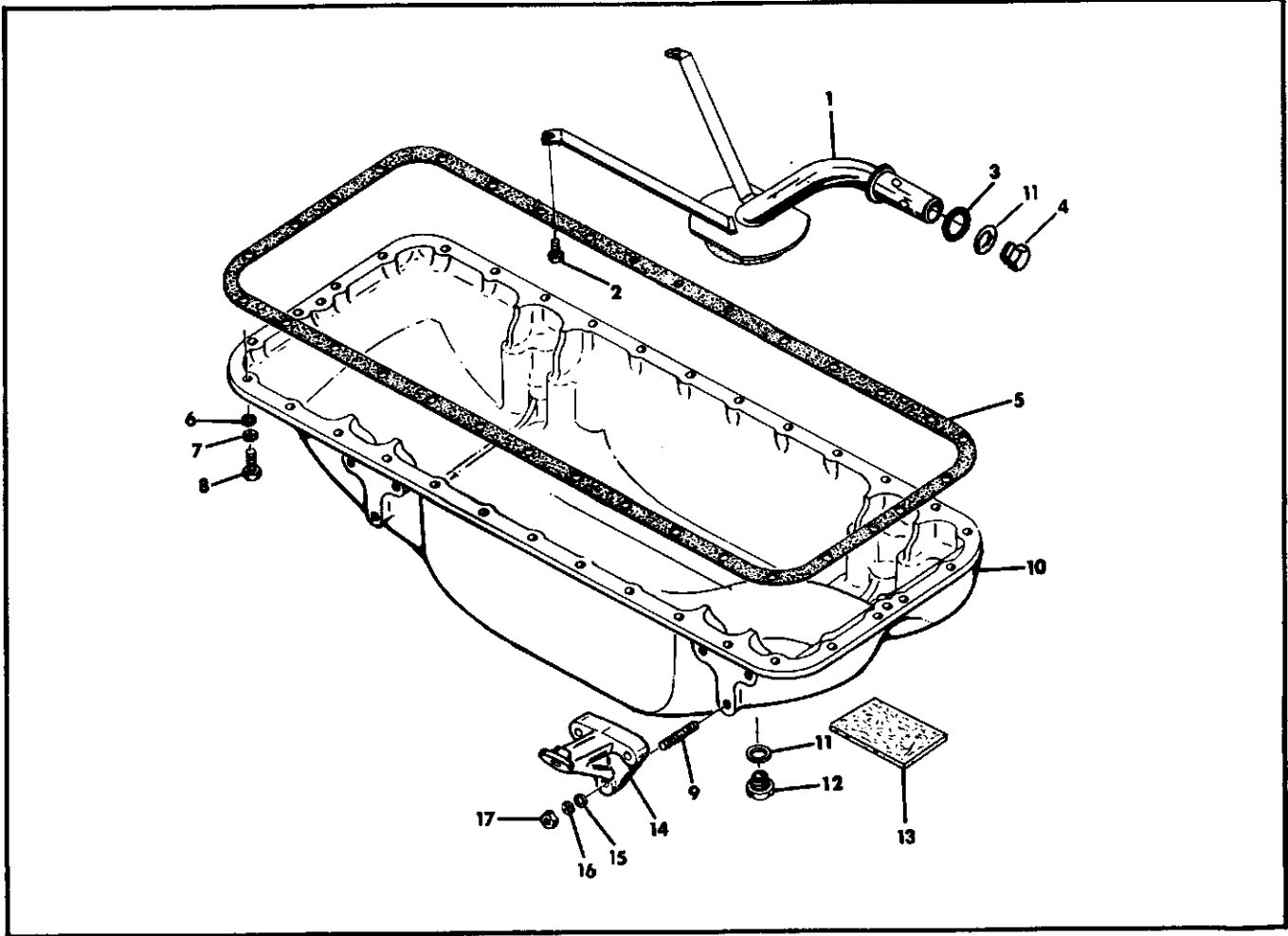

Figure 25. Oil Sump.

FIGURE & INDEX NO.	PART NUMBER	DESCRIPTION	UNITS PER ASS'Y.							USABLE ON CODE	
			1	2	3	4	5	6	7		
26- 1	534940	& Gasket, Suction Tube Assembly . . . . .								1	JL
- 2	635640	Tube Assembly, Oil Pump Suction . . . . .								1	JL
- 3	20522	Washer, Plain . . . . .								2	JL
- 4	AN74A4	Bolt, 1/4 X 15/32 In. Lg. . . . .								2	JL
- 5	AN74A3	Bolt. . . . .								2	JL
- 6	534743	& Gasket . . . . .								1	JL
- 7	635616	Sump Assembly, Oil . . . . .								1	JL
- 8	AN960-516L	Washer, Plain . . . . .								28	JL
- 9	13XX202B	Washer, Lock . . . . .								28	JL
-10	530346	Screw, 5/16 X 7/8 . . . . .								28	JL
-11	AN900-10	& Gasket. . . . .								1	JL
-12	532432	Plug . . . . .								1	JL

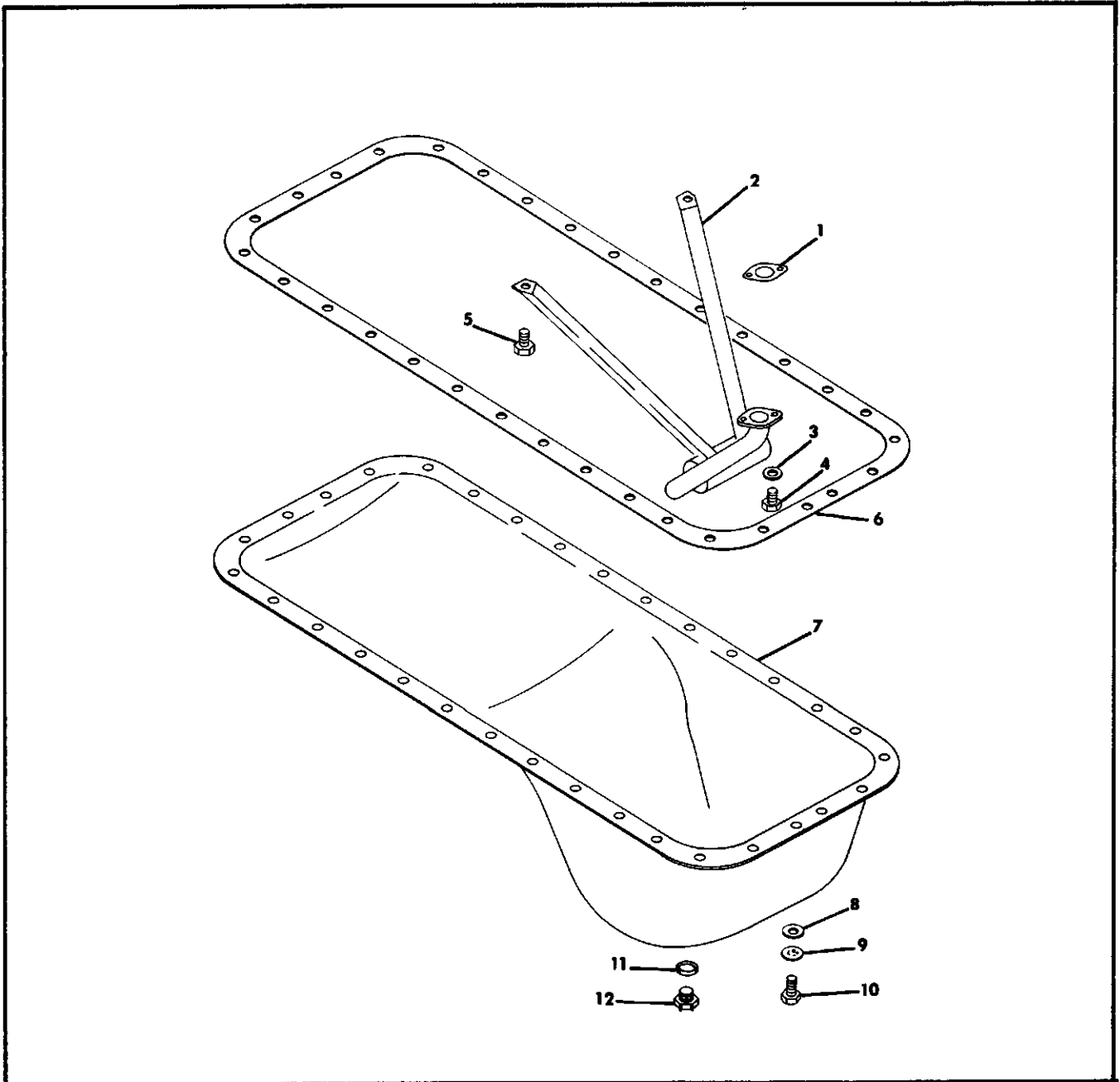

Figure 26. Oil Sump

FIGURE & INDEX NO.	PART NUMBER	DESCRIPTION	UNITS PER ASS'Y.							USABLE ON CODE	
			1	2	3	4	5	6	7		
27- 1	536413	\$ Gasket, Intake Manifold Flange . . . . .								6	D
- 2	629138	Tube Assembly, Intake Manifold, 1-2-3-4-5 Cylinder. . . . .								5	D
- 3	629325	Tube Assembly, Intake Manifold, No. 6 Cylinder. . . . .								1	D
ATTACHING PARTS											
- 4	20522	Washer, Plain . . . . .								24	D
- 5	AN936A416	Washer, Lock . . . . .								24	D
- 6	24835	Screw, 1/4-20 X 7/8 In. Lg. . . . .								24	D
* - - -											
- 7	631972	Clamp, Hose . . . . .								8	D
- 8	36151L	Clamp, Hose . . . . .								8	D
- 9	539487	Clamp Assembly, Hose . . . . .								2	D
-10	539571	Hose, Intake Manifold. . . . .								10	D
-11	535681	Tube, Elbow, 2-4-6 Side . . . . .								1	D
-12	627820	Tube Assembly, Elbow 1-3-5 Side . . . . .								1	D
-13	633435	Bracket, Balance Tube . . . . .								1	D
-14	AN737TW46	Clamp, Balance Tube Bracket . . . . .								1	D
-15	633434	Tube Assembly, Balance . . . . .								1	D
ATTACHING PARTS											
-16	13XX202B	Washer, Lock . . . . .								RF	D
-17	530346	Screw, 5/16-18 X 7/8 In. Lg. . . . .								RF	D
* - - -											
-18	629411A1	Throttle Assembly, Air (See Figure 29). . . . .								1	D
ATTACHING PARTS											
-19	AN960-516	Washer, Plain . . . . .								4	D
-20	AN75A15	Bolt . . . . .								2	D
-21	AN75A26	Bolt . . . . .								2	D
* - - -											
-22	2024	Plug, Pipe, 1/8-27 NPTF . . . . .								1	D

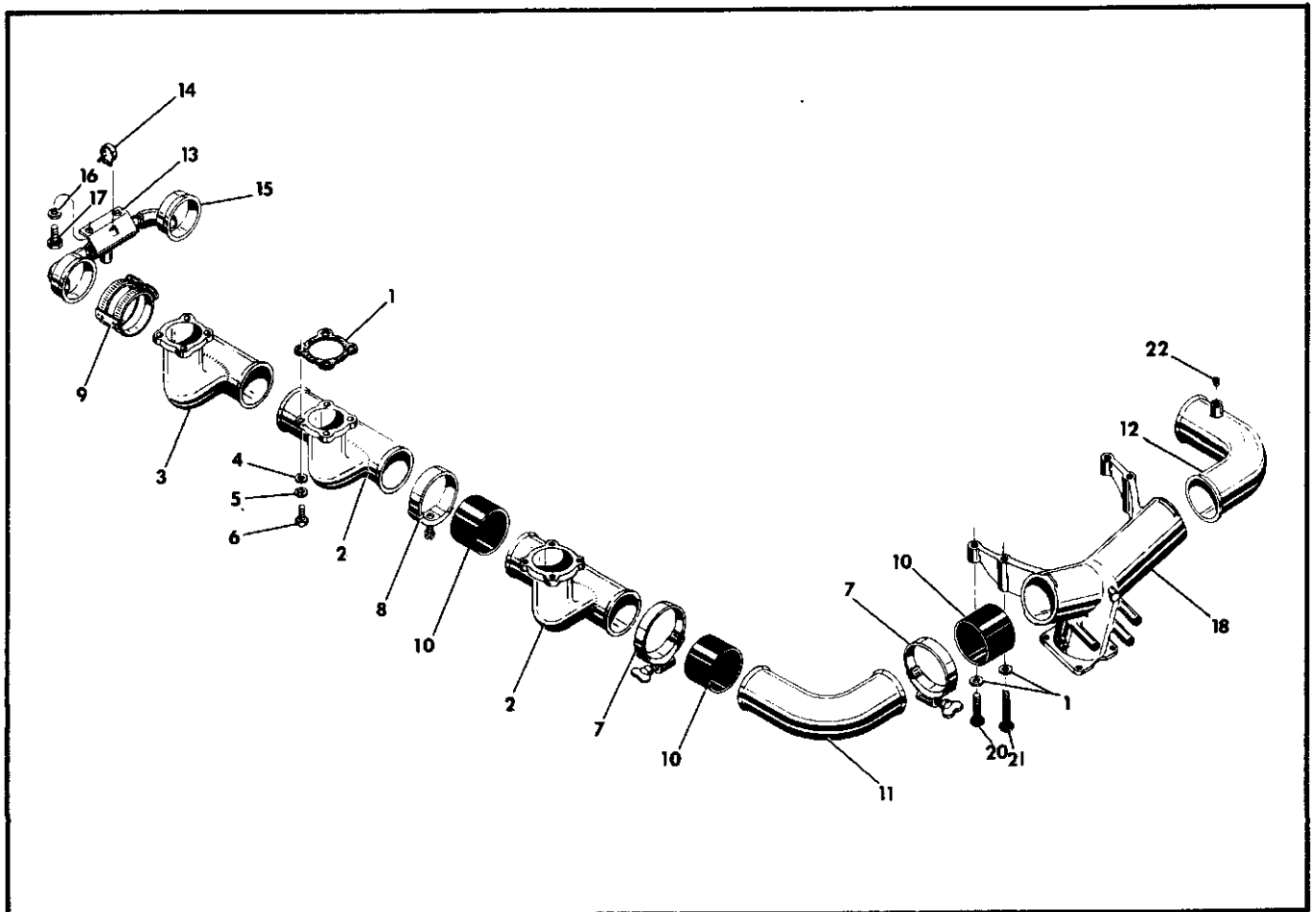

Figure 27. Induction System.

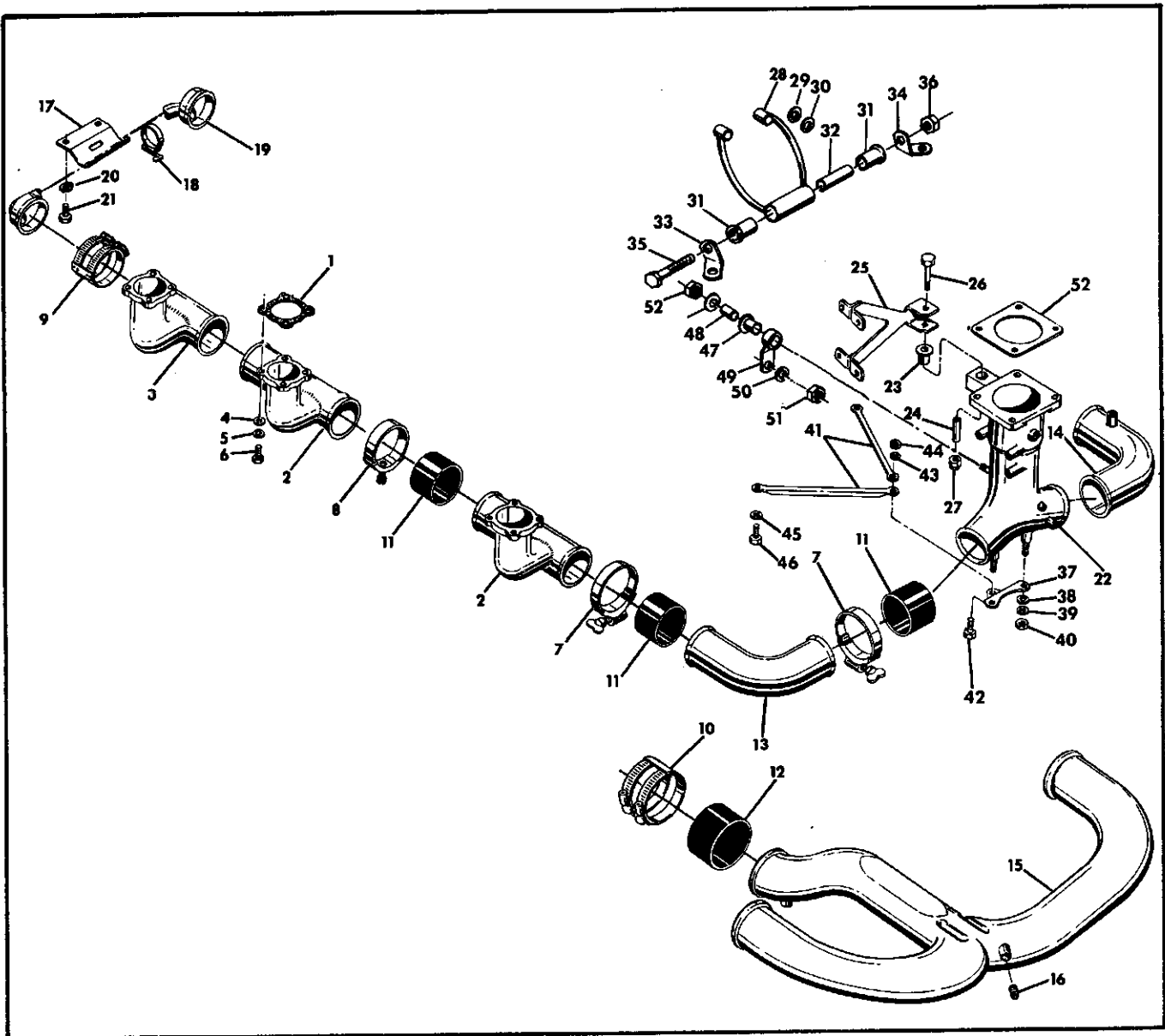

Figure 28. Induction System.

FIGURE & INDEX NO.	PART NUMBER	DESCRIPTION	UNITS PER ASS'Y.							USABLE ON CODE
			1	2	3	4	5	6	7	
28- 1	536413	\$ Gasket, Intake Manifold Flange . . . . .							6	ABC FJKL
- 2	629138	Tube Assembly, Intake Manifold, 1-2-3-4-5 Cylinder. . . . .							5	ABC FJKL
- 3	629325	Tube Assembly, Intake Manifold, No. 6 Cylinder . . . . .							1	ABC FJKL
ATTACHING PARTS										
- 4	20522	Washer, Plain . . . . .							24	ABC FJKL
- 5	AN936A416	Washer, Lock . . . . .							24	ABC FJKL
- 6	24835	Screw, 1/4-20 X 7/8 In. Lg. . . . .							24	ABC FJKL
- - - * - - -										
- 7	631972	Clamp, Hose . . . . .							8	AC FJKL
- 8	36151L	Clamp, Hose . . . . .							8	ABC FJKL
- 9	539487	Clamp Assembly, Hose . . . . .							2	AC FJKL
- 9	539487	Clamp Assembly, Hose . . . . .							4	B
-10	629163	Clamp Assembly, Hose . . . . .							1	B
-11	539571	Hose, Intake Manifold. . . . .							10	ABC FJKL
-11	539571	Hose, Intake Manifold. . . . .							8	B
-12	539023	Hose, Throttle Body-to-Manifold. . . . .							1	B
-13	627011	Tube Assembly, Elbow, 2-4-6 Side. . . . .							1	AFJKL
-13	630868	Tube Assembly, Elbow, 2-4-6 Side. . . . .							1	C

FIGURE & INDEX NO.	PART NUMBER	DESCRIPTION	UNITS	USABLE
			PER ASS'Y.	ON CODE
		1 2 3 4 5 6 7		
28-14	629595	Tube Assembly, Elbow, 1-3-5 Side. . . . .	1	AFJKL
-14	630866	Tube Assembly, Elbow, 1-3-5 Side. . . . .	1	C
-15	629601	Manifold Assembly . . . . .	1	B
-16	629518-1H	Plug, Pipe, 1/8-27 NPTF . . . . .	1	B
-17	628700	Bracket, Balance Tube . . . . .	1	AJ
-17	631406	Bracket, Balance Tube . . . . .	1	B
-17	632280	Bracket, Balance Tube . . . . .	1	C
-17	633129	Bracket, Balance Tube . . . . .	1	FL
-17	631790	Bracket, Balance Tube . . . . .	1	K
-18	AN737TW46	Clamp, Balance Tube Bracket . . . . .	1	ACFJK
-18	AN737TW48	Clamp, Band, Balance Tube . . . . .	1	L
-18	632444-2	Clamp, Band, Balance Tube . . . . .	1	B
-19	632369	Tube Assembly, Balance . . . . .	1	AJ
-19	631220	Tube Assembly, Balance . . . . .	1	B
-19	631661	Tube Assembly, Balance . . . . .	1	C
-19	633125	Tube Assembly, Balance . . . . .	1	F
-19	631745	Tube Assembly, Balance . . . . .	1	K
-19	635645	Tube Assembly, Balance . . . . .	1	L
		ATTACHING PARTS		
-20	13XX202B	Washer, Lock . . . . .	RF	ABCF
-21	530346	Screw, 5/16-18 X 7/8 In. Lg. . . . .	RF	AF
-21	539003	Bolt, 5/16-18 X 1-3/8 In. Lg. . . . .	2	B
-21	537961	Bolt, 5/16-18 X 1 In. Lg. . . . .	2	C
		* - - - *		
-22	629397A1	Throttle Assembly, Air (See Figure 26). . . . .	1	AFJKL
-22	631287A1	Throttle Assembly, Air (See Figure 28). . . . .	1	C
-23	629353	Bushing, Rubber, Air Valve Support . . . . .	2	AFJKL
-24	629354	Sleeve, Air Valve Support . . . . .	1	AFJKL
-25	630474	Bracket, Air Throttle Support . . . . .	1	AFJKL
		ATTACHING PARTS		
-26	537728	Bolt, 1/4-28 X 1-25/32 In. Lg. . . . .	1	AFJKL
-27	22661	Nut, Self Locking. . . . .	1	AFJKL
		* - - - *		
-28	631832	Bracket Assembly, Throttle Body Support. . . . .	1	C
		ATTACHING PARTS		
-29	24239	Spacer . . . . .	1	C
-30	539374	Washer . . . . .	1	C
		* - - - *		
-31	538468	Bushing, Throttle Body Support Bracket . . . . .	2	C
-32	539114	Sleeve, Throttle Body Support Bracket . . . . .	1	C
-33	632016	Bracket, Throttle Body Support Bracket L. H. . . . .	1	C
-34	632015	Bracket, Throttle Body Support Bracket R. H. . . . .	1	C
-35	AN4-26A	Bolt, 1/4-28 X 2-29/32 In. Lg. . . . .	1	C
-36	AN364-428	Nut, Self Locking. . . . .	1	C
-37	627836	Bracket, Air Valve Support . . . . .	1	AFJKL
		ATTACHING PARTS		
-38	20522	Washer, Plain . . . . .	2	AFJKL
-39	AN936A416	Washer, Lock . . . . .	2	AFJKL
-40	2437	Nut, Plain, Hex . . . . .	2	AFJKL
		* - - - *		
-41	627681	Bracket, Crankcase-to-Air Throttle . . . . .	2	AFJKL
		ATTACHING PARTS		
-42	535666	Screw, 5/16-24 X 25/32 In. Lg. . . . .	1	AFJKL
-43	AN936A516	Washer, Lock . . . . .	1	AFJKL
-44	AN315-5R	Nut, Plain, Hex . . . . .	1	AFJKL
-45	13XX202B	Washer, Lock . . . . .	RF	AFK
-46	537750	Screw, 5/16-18 X 1-1/8 In. Lg. . . . .	2	AFK
		* - - - *		
-47	631836	Bushing, Throttle Support Bracket . . . . .	2	C
-48	631837	Sleeve, Throttle Support Bracket. . . . .	1	C
-49	631840	Bracket Assembly, Air Valve Support . . . . .	1	C
		ATTACHING PARTS		
-50	538100	Washer, Plain . . . . .	2	C
-51	2437	Nut, Plain, Hex . . . . .	2	C
		* - - - *		
-52	630350	\$ Gasket, Air Throttle Body. . . . .	1	AFJKL
-52	627368	\$ Gasket, Air Throttle Body. . . . .	1	C



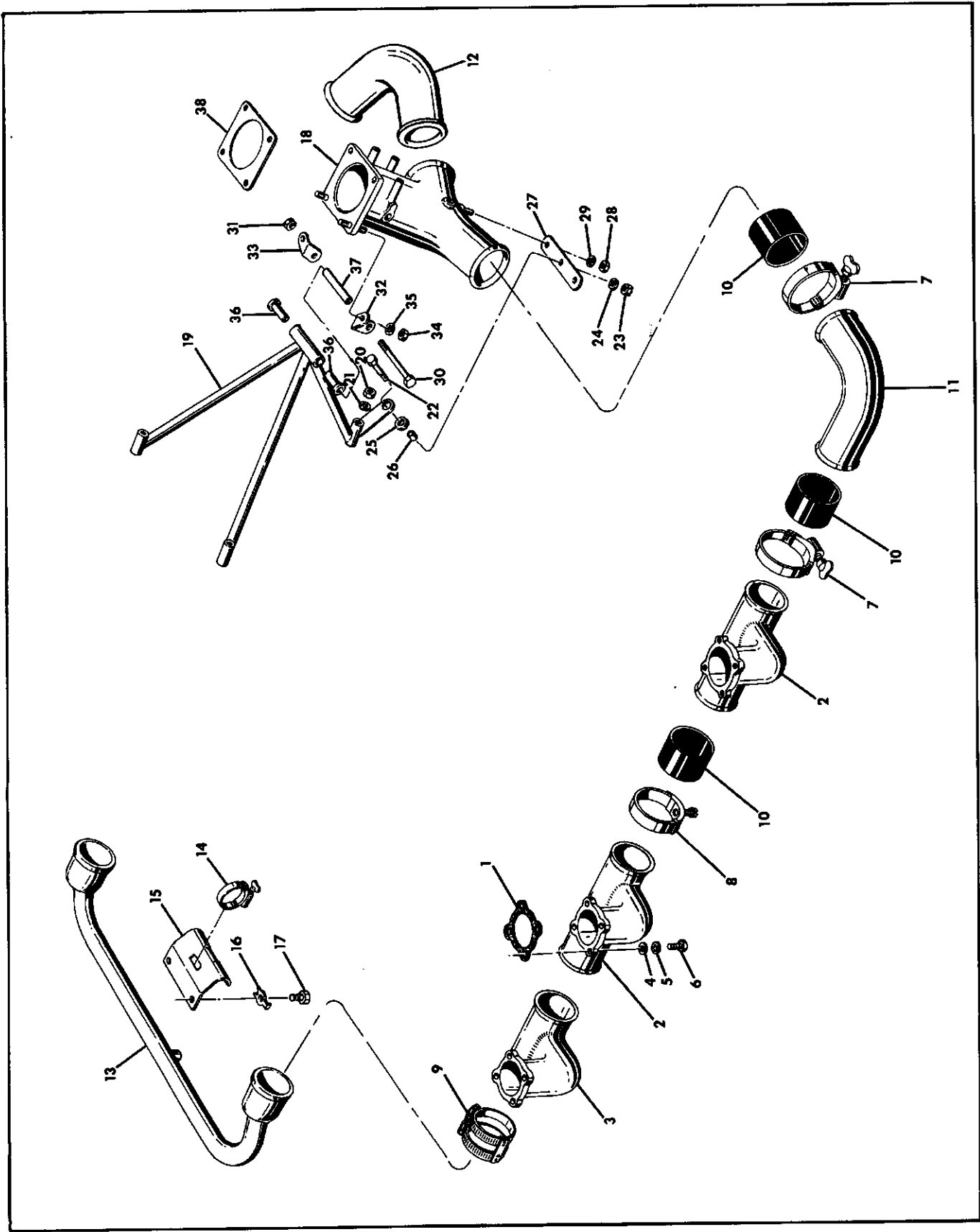

Figure 29. Induction System.

FIGURE & INDEX NO.	PART NUMBER	DESCRIPTION	UNITS	USABLE
			PER ASSY.	ON CODE
		1 2 3 4 5 6 7		
29- 1	536413	\$ Gasket, Intake Manifold Flange . . . . .	6	E
- 2	629138	Tube Assembly, Intake Manifold, 1-2-3-4-5 Cylinder. . . . .	5	E
- 3	629325	Tube Assembly, Intake Manifold, No. 6 Cylinder . . . . .	1	E
		ATTACHING PARTS		
- 4	20522	Washer, Plain . . . . .	24	E
- 5	AN936A416	Washer, Lock . . . . .	24	E
- 6	24835	Screw, 1/4-20 X 7/8 In. Lg. . . . .	24	E
		- - - * - - -		
- 7	631972	Clamp, Hose . . . . .	8	E
- 8	36151L	Clamp, Hose . . . . .	8	E
- 9	539487	Clamp Assembly, Hose . . . . .	2	E
-10	539571	Hose, Intake Manifold. . . . .	10	E
-11	633822	Tube Assembly, Elbow, 2-4-6 Side. . . . .	1	E
-12	633821	Tube Assembly, Elbow, 1-3-5 Side. . . . .	1	E
-13	628766	Tube Assembly, Balance . . . . .	1	E
-14	AN737TW46	Clamp, Balance Tube Bracket . . . . .	1	E
-15	633435	Bracket, Balance Tube-to-Sump . . . . .	1	E
		ATTACHING PARTS		
-16	13XX202B	Washer, Lock . . . . .	RF	E
-17	530346	Screw, 5/16-18 X 7/8 In. Lg. . . . .	RF	E
		- - - * - - -		
-18	628861A1	Throttle Assembly, Air . . . . .	1	E
-19	633823	Bracket Assembly, Air Throttle Support . . . . .	1	E
-20	2437	Nut, Hex, 1/4-28. . . . .	1	E
-21	AN936A416	Washer, Lock . . . . .	1	E
-22	AN4-7A	Bolt, 1/4-28 X 29/32 In. Lg. . . . .	1	E
-23	22661	Nut, Self Locking, 1/4-28 . . . . .	1	E
-24	538100	Washer, Grommet-to-Bracket . . . . .	1	E
-25	M330S208	Grommet, Air Throttle Bracket . . . . .	1	E
-26	628833	Sleeve, Air Throttle Bracket. . . . .	1	E
-27	628816	Bracket, Air Throttle Lower. . . . .	1	E
		ATTACHING PARTS		
-28	2437	Nut, Hex, 1/4-28. . . . .	2	E
-29	AN936A416	Washer, Lock, 1/4 In. . . . .	2	E
		- - - * - - -		
-30	AN4-26A	Bolt, 1/4-28 X 2-25/32 In. Lg. . . . .	1	E
-31	22661	Nut, Self-Locking, 1/4-28. . . . .	1	E
-32	538470	Bracket, Air Valve Support, Left Side . . . . .	1	E
-33	539113	Bracket, Air Valve Support, Right Side . . . . .	1	E
-34	23890	Nut, Hex, 1/4-20. . . . .	2	E
-35	AN936A416	Washer, Lock, 1/4 In. . . . .	2	E
-36	538468	Bushing, Air Valve Support . . . . .	2	E
-37	539114	Sleeve, Air Valve Support, Upper . . . . .	1	E
-38	630350	\$ Gasket, Air Throttle Body. . . . .	1	E

FIGURE & INDEX NO.	PART NUMBER	DESCRIPTION	UNITS	USABLE
			PER ASS'Y.	ON CODE
		1 2 3 4 5 6 7		
30- 1	631684	Gear Assembly, Fuel Pump . . . . .	1	AFJKL
- 2	539634	. Plug . . . . .	1	AFJKL
- 3	No Number	. Gear . . . . .	NS	AFJKL
- 4	631685	\$ Gasket, Fuel Pump-to-Crankcase . . . . .	1	AFJKL
- 5	631683	Coupling, Fuel Pump Drive . . . . .	1	AFJKL
	EQ5991A	Fuel Injector Equipment, Complete. . . . .	1	AFJKL
	630947-1A1	. Fuel Pump Assembly, Complete . . . . .	1	AFJKL
- 6	No Number	. . Fuel Pump Assembly . . . . .	NS	AFJKL
- 7	631882	. . Elbow, 90 Degree, Fuel Pump Inlet . . . . .	1	AFJKL
- 8	628436	. . Elbow, 45 Degree, Fuel Pump-to-Metering Unit . . . . .	1	AFJKL
- 9	627119	. . Elbow, 90 Degree, Mixture Return at Fuel Pump . . . . .	1	AFJKL
-10	628476	. . Elbow, 45 Degree, Mixture Return at Fuel Pump . . . . .	1	AFJKL
-11	628438	. . Fitting, Vapor Return. . . . .	1	AFJKL
-12	627119	. . Elbow, 90 Degree, Vapor Return. . . . .	1	AFJKL
-13	628438	. . Fitting, Fuel Pump Seal Drain. . . . .	1	AFJKL
-14	631932	. . Shroud Assembly . . . . .	1	AFJKL
-15	532377	. . Spring . . . . .	1	AFJKL
-16	626879-1	. . Grommet . . . . .	3	AFJKL
-17	AN526-1024-4	. . Screw . . . . .	2	AFJKL
-18	534337	. . Nut, Speed. . . . .	2	AFJKL
	629399A1	. Throttle Body & Control Assembly . . . . .	1	AFJKL
	629397A1	. . Throttle & Lever Assembly . . . . .	1	AFJKL
-19	631819	. . Shaft, Air Throttle . . . . .	1	AFJKL
-20	625601	. . . Plate, Air Throttle . . . . .	1	AFJKL
ATTACHING PARTS				
-21	539942	. . . Screw . . . . .	2	AFJKL
		* - - -		
-22	625457	. . . Washer, Plain . . . . .	2	AFJKL
-23	625327-1	. . . Washer, Wave . . . . .	2	AFJKL
-24	629329	. . . Lever, Throttle Shaft . . . . .	1	AFJKL
-25	631818	. . . Lever, Throttle Shaft . . . . .	1	AFJKL
-26	626813	. . . Pin, Tubular. . . . .	2	AFJKL
-27	626634	. . . Spring, Idle Adjusting. . . . .	1	AFJKL
-28	626586	. . . Screw, Idle Adjusting. . . . .	1	AFJKL
-29	402711	† . . Stud, 1/4 X 7/8 In. Lg. . . . .	2	AF
-30	629703-2A2	. . Control Assembly. . . . .	1	AFJKL
-31	629351	. . . Lever, Mixture Control . . . . .	1	AFJKL
-32	626813-1	. . . Pin, Tubular. . . . .	1	AFJKL
-33	630119	. . . Adapter, Fuel Inlet From Pump . . . . .	1	AFJKL
-34	628478	. . . Elbow, 90 Degree, Fuel Inlet From Pump. . . . .	1	AFJKL
-35	628438	. . . Fitting, Fuel Outlet-to-Manifold Valve . . . . .	1	AFJKL
-36	628478	. . . Elbow, 90 Degree, Mixture Return-to-Fuel Pump . . . . .	1	AFJKL
-37	626183	. . . Gasket . . . . .	1	AFJKL
-38	539959	. . . Screen and Plug Assembly. . . . .	1	AFJKL
-39	AN932-2	. . . Plug, Pipe . . . . .	2	AFJKL
-40	629364	. . Rod Assembly, Link . . . . .	1	AFJKL
-41	626634	. . Spring . . . . .	1	AFJKL
-42	629330	. . Rod End . . . . .	1	AFJKL
-43	MS20365-1032A	. . Nut, Self Locking. . . . .	1	AFJKL
-44	625327-2	. . Washer, Wave . . . . .	2	AFJKL
-45	537690	. . Washer, Plain . . . . .	2	AFJKL
-46	2500	. . Pin, Cotter . . . . .	2	AFJKL
-47	501867	. . Washer, Tab. . . . .	3	AFJKL
-48	630387	. . Screw . . . . .	3	AFJKL
-49	629338	. Shroud. . . . .	1	AFJKL
ATTACHING PARTS				
-50	20522	. Washer, Plain . . . . .	3	AFJKL
-51	AN936A416	. Washer, Lock . . . . .	3	AFJKL
-52	2437	. Nut . . . . .	3	AFJKL
		* - - -		
-53	635158-14.00	. . Hose Assembly, Fuel Pump-to-Control . . . . .	1	AFJKL
-54	635158-10.00	. . Hose Assembly, Control-to-Fuel Pump . . . . .	1	AFJKL
-55	635158-32.00	. . Hose Assembly, Control-to-Manifold Valve . . . . .	1	AFJKL
	631351A10	. Fuel Manifold Valve Assembly . . . . .	1	AFJKL
-56	631720	. . Elbow, 90 Degree, Pressure Connector. . . . .	1	AFJKL
-57	628437	. . Elbow, 90 Degree, Fuel Inlet . . . . .	1	AFJKL
-58	627331	. . Elbow, 45 Degree, Cylinder 1-2-5-6 . . . . .	4	AFJKL
-59	AN780-2	. . Nipple, Union, Cylinder 3-4 . . . . .	2	AFJKL

FIGURE & INDEX NO.	PART NUMBER	DESCRIPTION	UNITS PER ASS'Y.							USABLE ON CODE	
			1	2	3	4	5	6	7		
30-60	634011	Bracket, Fuel Manifold-to-Crankcase								1	AFJKL
ATTACHING PARTS											
-61	AN500-10-5	Screw								2	AFJKL
-62	AN936A10	Washer, Lock								2	AFJKL
- - - * - - -											
-63	631330	Seal								1	AFJKL
-64	626557	Screen								1	AFJKL
-65	630184	Spring								1	AFJKL
-66	626553	Cover								1	AFJKL
ATTACHING PARTS											
-67	AN500A8-10	Screw								4	AFJKL
- - - * - - -											
-68	628154	Tube Assembly, Cylinder 1 & 6								2	AFJKL
	628153	Tube Assembly, Cylinder 2 & 5								2	AFJKL
	628152	Tube Assembly, Cylinder 3 & 4								2	AFJKL
-69	628301	Bracket, Fuel Discharge Tube								1	AFJKL
	628295	Bracket, Fuel Discharge Tube								1	AFJKL
-70	626577-2	Clamp								6	AFJKL
-71	627335D13	* Nozzle Assembly								6	AFJKL

NOTE: (\*) Check dash number on old nozzle for complete part number.

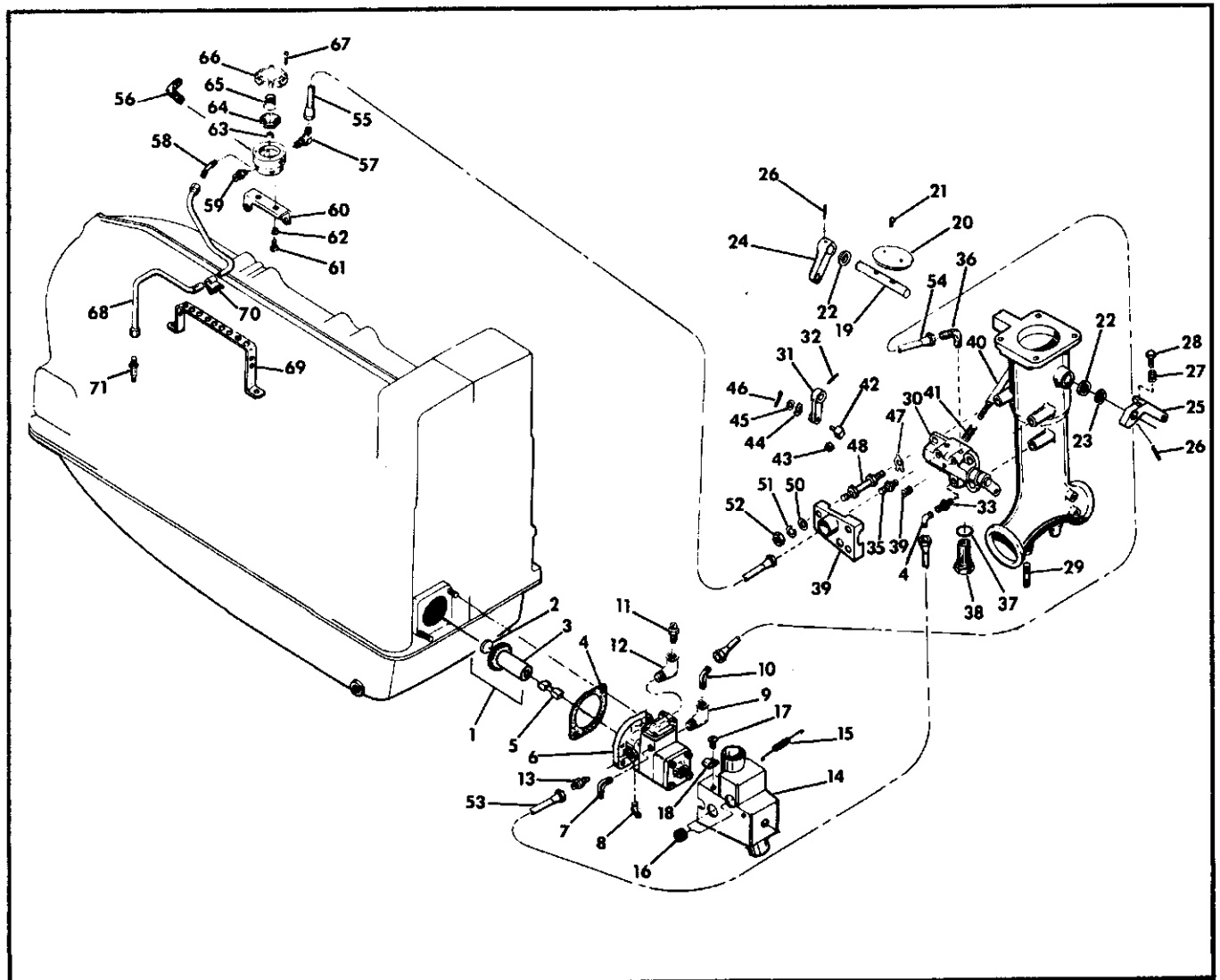

Figure 30. Fuel Injection System.

FIGURE & INDEX NO.	PART NUMBER	DESCRIPTION	UNITS PER ASS'Y.	USABLE ON CODE		
					1	2
31- 1	630763	\$ Gasket . . . . .	1	B		
- 2	631263	Coupling, Crankshaft Gear. . . . .	1	B		
	EQ5965B	Fuel Injector Equipment, Complete. . . . .	1	B		
	630947-2A1	Fuel Pump Assembly, Complete . . . . .	1	B		
- 3	No Number	Fuel Pump Assembly . . . . .	NS	B		
- 4	632017	Elbow, 90 Degree, Fuel Pump Inlet . . . . .	1	B		
- 5	628437	Elbow, 90 Degree, Fuel Pump Outlet . . . . .	1	B		
- 6	628478	Elbow, 90 Degree, Mixture Return . . . . .	1	B		
- 7	628476	Elbow, 45 Degree, Vapor Return. . . . .	1	B		
- 8	632115	Elbow, Hose, 45 Degree, Drain . . . . .	1	B		
- 9	631764	Shroud Assembly, Fuel Pump . . . . .	1	B		
-10	626879-1	Grommet . . . . .	3	B		
	631415A1	Throttle Body & Control Assembly . . . . .	1	B		
	631408A1	Throttle & Lever Assembly . . . . .	1	B		
-11	630124	Shaft, Throttle . . . . .	1	B		
-12	625601	Plate, Throttle . . . . .	1	B		
		ATTACHING PARTS				
-13	539942	Screw . . . . .	2	B		
		- - - * - - -				
-14	625327	Washer, Wave . . . . .	1	B		
-15	625457	Washer, Plain . . . . .	2	B		
-16	625238	Collar, Air Throttle . . . . .	1	B		
-17	629871	Lever Assembly, Throttle Nut Control . . . . .	1	B		
-18	626813	Pin, Tubular. . . . .	2	B		
-19	626634	Spring. . . . .	1	B		
-20	626586	Screw, Adjusting . . . . .	1	B		
-21	629904-2A2	Control Assembly. . . . .	1	B		
-22	632081	Lever, Throttle Control. . . . .	1	B		
-23	2457	Nut . . . . .	1	B		
-24	X604	Pin, Cotter . . . . .	1	B		
-25	628478	Elbow, Fuel Inlet & Fuel Return-to-Pump. . . . .	2	B		
-26	AN932-2	Plug. . . . .	2	B		
-27	630119	Adapter . . . . .	1	B		
-28	627119	Elbow . . . . .	1	B		
-29	630119	Adapter . . . . .	1	B		
-30	628437	Elbow, 90 Degree, Fuel Outlet. . . . .	1	B		
-31	626183	Gasket . . . . .	1	B		
-32	539959	Screen & Plug Assembly. . . . .	1	B		
-33	625539A1	Rod Assembly, Link . . . . .	1	B		
-34	626634	Spring. . . . .	1	B		
-35	625542	Rod, End . . . . .	1	B		
-36	MS20365-1032A	Nut, Self Locking. . . . .	1	B		
-37	625327-2	Washer, Wave . . . . .	2	B		
-38	537690	Washer, Plain . . . . .	2	B		
-39	2500	Pin, Cotter . . . . .	2	B		
-40	501867	Washer, Tab. . . . .	3	B		
-41	630327	Screw . . . . .	3	B		
-42	632859	Shroud. . . . .	1	B		
		ATTACHING PARTS				
-43	20522	Washer . . . . .	3	B		
-44	AN936A416	Washer, Lock . . . . .	3	B		
-45	2437	Nut . . . . .	3	B		
		- - - * - - -				
-46	635158-38.00	Hose Assembly, Control-to-Fuel Pump Outlet & Return . . . . .	2	B		
-47	635158-32.00	Hose, Control-to-Manifold Valve. . . . .	1	B		
	631427A6	Fuel Manifold Valve Assembly . . . . .	1	B		
-48	628437	Elbow, 90 Degree . . . . .	1	B		
-49	631658	Elbow, Fuel Pressure. . . . .	1	B		
-50	627331	Elbow, Union, 45 Degree . . . . .	4	B		
-51	AN780-2	Nipple, Union . . . . .	2	B		
-52	634011	Bracket, Fuel Manifold-to-Crankcase . . . . .	1	B		
		ATTACHING PARTS				
-53	AN500-10-5	Screw . . . . .	2	B		
-54	AN936A10	Washer, Lock . . . . .	2	B		
		- - - * - - -				
-55	631330	Seal. . . . .	1	B		
-56	626557	Screen . . . . .	1	B		
-57	627378	Spring. . . . .	1	B		

FIGURE & INDEX NO.	PART NUMBER	DESCRIPTION							UNITS PER ASS'Y.	USABLE ON CODE
		1	2	3	4	5	6	7		
-58	628553	. .	Cover . . . . .	. . . . .	. . . . .	. . . . .	. . . . .	. . . . .	1	B
ATTACHING PARTS										
-59	AN500A8-10	. .	Screw . . . . .	. . . . .	. . . . .	. . . . .	. . . . .	. . . . .	4	B
31-60	628154	. .	Tube Assembly . . . . .	. . . . .	. . . . .	. . . . .	. . . . .	. . . . .	2	B
	628153	. .	Tube Assembly . . . . .	. . . . .	. . . . .	. . . . .	. . . . .	. . . . .	2	B
	628152	. .	Tube Assembly . . . . .	. . . . .	. . . . .	. . . . .	. . . . .	. . . . .	2	B
-61	631246	. .	Bracket, Fuel Discharge Tube . . . . .	. . . . .	. . . . .	. . . . .	. . . . .	. . . . .	1	B
-61	626486	. .	Bracket, Fuel Discharge Tube . . . . .	. . . . .	. . . . .	. . . . .	. . . . .	. . . . .	1	B
-62	626577-2	. .	Clamp . . . . .	. . . . .	. . . . .	. . . . .	. . . . .	. . . . .	6	B
-63	627335D13	* .	Nozzle . . . . .	. . . . .	. . . . .	. . . . .	. . . . .	. . . . .	6	B

NOTE: (\*) Check dash number on old nozzle for complete part number.

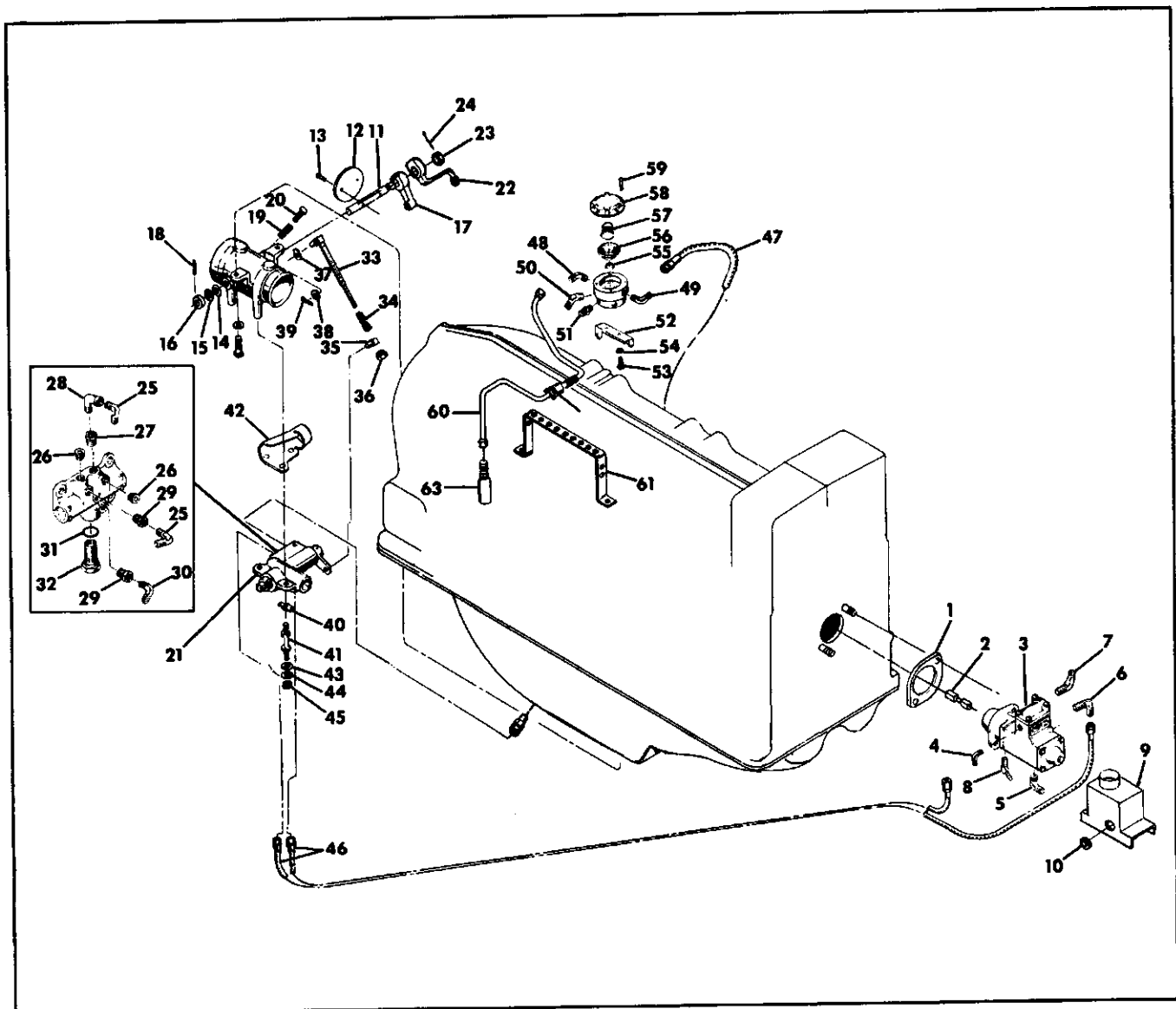

Figure 31. Fuel Injection System.

FIGURE & INDEX NO.	PART NUMBER	DESCRIPTION	UNITS PER ASSY.	USABLE ON CODE		
					1	2
32- 1	630763	\$ Gasket, Fuel Pump Adapter . . . . .	1	C		
- 2	631263	Coupling, Crankshaft Gear-to-Fuel Pump . . . . .	1	C		
	EQ5966C	Fuel Injector Equipment, Complete . . . . .	1	C		
	630947-2A2	Fuel Pump Assembly, Complete . . . . .	1	C		
- 3	No Number	Fuel Pump Assembly . . . . .	NS	C		
- 4	632017	Elbow, Fuel Pump Inlet . . . . .	1	C		
- 5	633121	Elbow, 45 Degree. . . . .	1	C		
- 6	628437	Elbow, 90 Degree. . . . .	1	C		
- 7	628476	Elbow, 45 Degree . . . . .	1	C		
- 8	628438	Fitting, Connector . . . . .	1	C		
- 9	631308	Connector . . . . .	1	C		
-10	632115	Elbow, 45 Degree, Drain . . . . .	1	C		
-11	631764	Shroud Assembly . . . . .	1	C		
-12	626879-1	Grommet . . . . .	1	C		
	631550A1	Throttle Body & Control Assembly . . . . .	1	C		
	631287A1	Throttle & Lever Assembly . . . . .	1	C		
-13	633379	Shaft, Throttle . . . . .	1	C		
-14	625601	Plate, Throttle. . . . .	1	C		
		ATTACHING PARTS				
-15	539942	Screw . . . . .	1	C		
		* - - - *				
-16	625327-1	Washer, Wave . . . . .	1	C		
-17	625238	Collar, Air Throttle . . . . .	1	C		
-18	625457	Washer, Plain . . . . .	2	C		
-19	632556	Lever Assembly, Throttle Heat Control. . . . .	1	C		
-20	626813	Pin, Tubular. . . . .	2	C		
-21	626634	Spring, Compression . . . . .	1	C		
-22	626586	Screw, Adjusting . . . . .	1	C		
-23	632916-2A1	Control Assembly. . . . .	1	C		
-24	630146-3	Lever, Mixture Control . . . . .	1	C		
-25	X604	Pin, Cotter . . . . .	1	C		
-26	2457	Nut . . . . .	1	C		
-27	628437	Elbow, 90 Degree, Fuel Inlet . . . . .	1	C		
-28	628478	Elbow, 90 Degree, Metering Unit-to-Manifold Valve . . . . .	1	C		
-29	628437	Elbow, 90 Degree, Mixture Return-to-Pump. . . . .	1	C		
-30	626183	Gasket . . . . .	1	C		
-31	539959	Plug & Screen Assembly. . . . .	2	C		
-32	AN932-2	Plug, Pipe . . . . .	1	C		
-33	632558A1	Rod Assembly, Link . . . . .	1	C		
-34	626634	Spring. . . . .	1	C		
-35	632557	Rod End . . . . .	1	C		
-36	MS20365-1032A	Nut, Self Locking. . . . .	1	C		
-37	625327-2	Washer, Wave . . . . .	2	C		
-38	537690	Washer . . . . .	2	C		
-39	2500	Pin, Cotter . . . . .	2	C		
-40	501867	Washer, Tab. . . . .	2	C		
-41	630387	Screw . . . . .	1	C		
-42	537629	Screw . . . . .	1	C		
-43	632551	Shroud . . . . .	1	C		
		ATTACHING PARTS				
-44	20522	Washer, Plain . . . . .	1	C		
-45	AN936A416	Washer, Lock . . . . .	1	C		
-46	2437	Nut . . . . .	1	C		
		* - - - *				
-47	635158-12.00	Hose Assembly. . . . .	2	C		
-48	635158-40.00	Hose Assembly. . . . .	1	C		
	631427A10	Fuel Manifold Valve Assembly . . . . .	1	C		
-49	631658	Elbow, 90 Degree, Pressure Connector. . . . .	1	C		
-50	628437	Elbow, 90 Degree, Fuel Inlet . . . . .	4	C		
-51	627331	Elbow, Union, 45 Degree . . . . .	2	C		
-52	AN780-2	Nipple, Union . . . . .	1	C		
-53	634011	Bracket, Fuel Manifold-to-Crankcase . . . . .	1	C		
		ATTACHING PARTS				
-54	AN500-10-5	Screw . . . . .	2	C		
-55	AN936A10	Washer, Lock . . . . .	2	C		
		* - - - *				

FIGURE & INDEX NO.	PART NUMBER	DESCRIPTION							UNITS PER ASS'Y.	USABLE ON CODE
		1	2	3	4	5	6	7		
32-56	631330	..	..	..	..	..	..	..	1	C
-57	627378	..	..	..	..	..	..	..	1	C
-58	626553	..	..	..	..	..	..	..	1	C
ATTACHING PARTS										
-60	AN500A8-10	..	..	..	..	..	..	..	4	C
- - - *										
-61	628154	..	..	..	..	..	..	..	2	C
	628153	..	..	..	..	..	..	..	2	C
	628152	..	..	..	..	..	..	..	2	C
-62	631246	..	..	..	..	..	..	..	2	C
-63	626577-2	..	..	..	..	..	..	..	6	C
-64	627335D13	* ..	..	..	..	..	..	..	6	C

NOTE: (\*) Check dash number on old nozzle for complete part number.

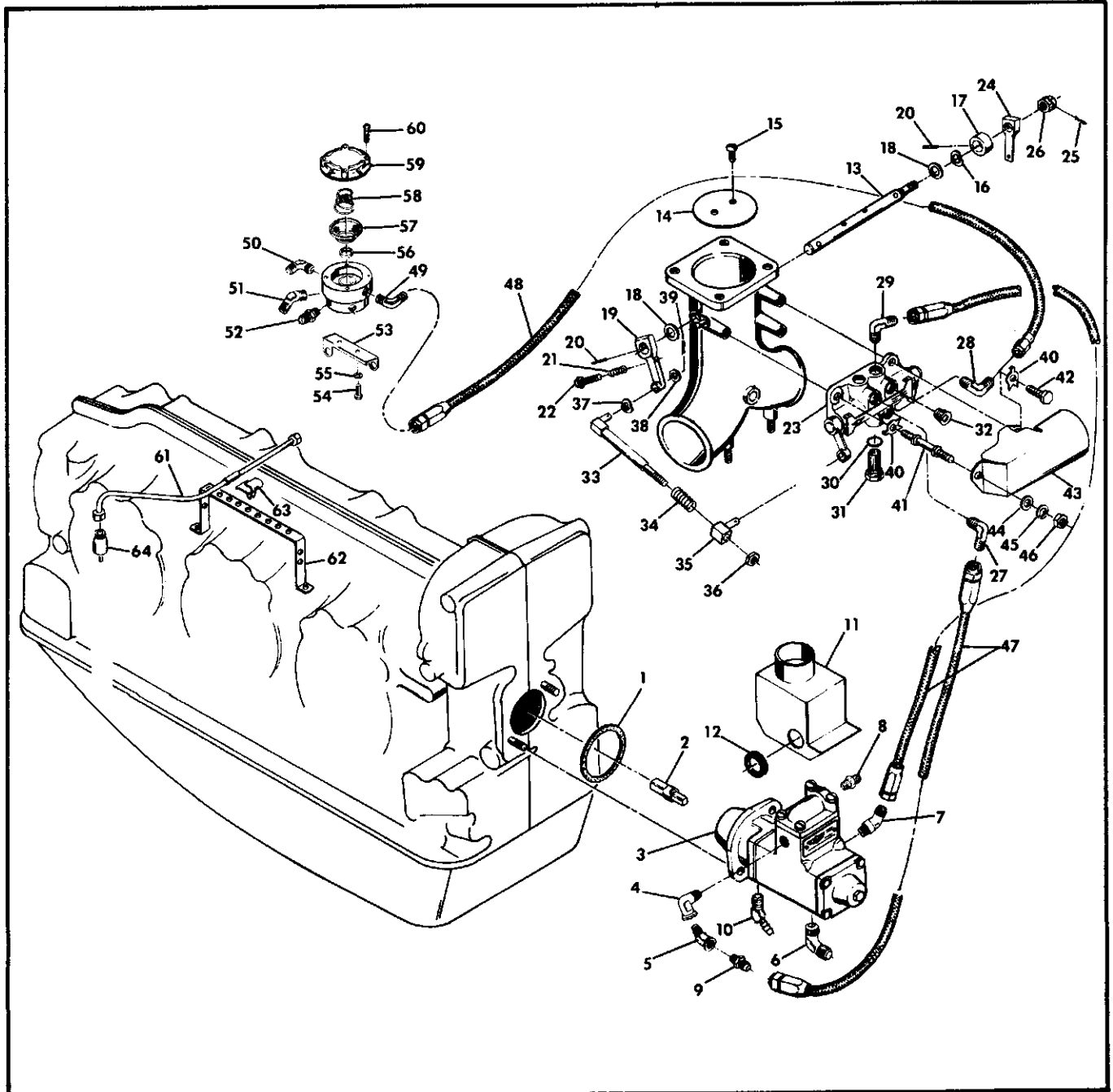

Figure 32. Fuel Injection System.



FIGURE & INDEX NO.	PART NUMBER	DESCRIPTION	UNITS	USABLE
			PER ASS'Y.	ON CODE
33- 1	631684	Gear Assembly, Fuel Pump . . . . .	1	D
- 2	539634	. Plug . . . . .	1	D
- 3	No Number	. Gear . . . . .	NS	D
- 4	631685	Gasket, Fuel Pump-to-Crankcase . . . . .	1	D
- 5	631683	Coupling, Fuel Pump Drive . . . . .	1	D
	EQ6085D	Fuel Injector Equipment, Complete . . . . .	1	D
	630947-1A3	. Fuel Pump Assembly, Complete . . . . .	1	D
- 6	No Number	. Fuel Pump Assembly . . . . .	NS	D
- 7	628475	. Elbow, 90 Degree, Fuel Pump Inlet . . . . .	1	D
- 8	628438	. Fitting, Fuel Outlet. . . . .	1	D
- 9	627119	. Elbow, 90 Degree, Mixture Return-at-Fuel Pump . . . . .	1	D
-10	628476	. Elbow, 45 Degree, Mixture Return-at-Fuel Pump . . . . .	1	D
-11	628437	. Fitting, Fuel Return . . . . .	1	D
-12	628438	. Fitting, Drain . . . . .	1	D
-13	631764	. Shroud Assembly . . . . .	1	D
-14	626879-1	. Grommet . . . . .	3	D
-15	AN526-1024-4	. Screw . . . . .	1	D
-16	534337	. Nut, Speed. . . . .	1	D
	629431A2	Throttle Body & Control Assembly . . . . .	1	D
	629411A1	. Throttle & Lever Assembly . . . . .	1	D
-17	625600	. Shaft, Air Throttle . . . . .	1	D
-18	625601	. Plate, Air Throttle . . . . .	1	D
ATTACHING PARTS				
-19	539942	. . . . Screw . . . . .	2	D
		- - - * - - -		
-20	625457	. . . . Washer, Plain . . . . .	2	D
-21	625327-1	. . . . Washer, Wave . . . . .	1	D
-22	625228	. . . . Lever, Throttle Control. . . . .	1	D
-23	626813	. . . . Pin, Tubular. . . . .	1	D
-24	626634	. . . . Spring, Idle Adjusting. . . . .	1	D
-25	626586	. . . . Screw, Idle Adjusting. . . . .	1	D
-26	625219-2A13	. . . . Control Assembly. . . . .	1	D
-27	627819	. . . . Lever, Mixture Control . . . . .	1	D
-28	626813	. . . . Pin, Tubular . . . . .	1	D
-29	AN500-10-10	. . . . Screw . . . . .	1	D
-30	13XX260	. . . . Lockwasher . . . . .	1	D
-31	630119	. . . . Adapter, Fuel Inlet-from-Pump . . . . .	1	D
-32	628437	. . . . Elbow, 90 Degree, Fuel Inlet . . . . .	1	D
-33	628437	. . . . Elbow, 90 Degree, Fuel Outlet-to-Manifold Valve . . . . .	1	D
-34	628476	. . . . Elbow, 45 Degree, Mixture Return-to-Fuel Pump . . . . .	1	D
-35	630119	. . . . Adapter, Fuel Return-to-Pump. . . . .	1	D
-36	626183	. . . . Gasket . . . . .	1	D
-37	539959	. . . . Screen & Plug Assembly. . . . .	1	D
-38	AN932-2	. . . . Plug, Pipe. . . . .	2	D
-39	625539	. . . . Rod Assembly, Link . . . . .	1	D
-40	626634	. . . . Spring . . . . .	1	D
-41	625542	. . . . Rod End . . . . .	1	D
-42	MS20365-1032A	. . . . Nut, Self Locking . . . . .	1	D
-43	625327-2	. . . . Washer, Wave . . . . .	2	D
-44	537690	. . . . Washer, Plain . . . . .	2	D
-45	2500	. . . . Pin, Cotter . . . . .	2	D
-46	501867	. . . . Washer, Tab. . . . .	3	D
-47	630327	. . . . Screw . . . . .	3	D
-48	632859	. Shroud. . . . .	1	D
ATTACHING PARTS				
-49	20522	. Washer, Plain . . . . .	3	D
-50	AN936A416	. Washer, Lock . . . . .	3	D
-51	AN315-4R	. Nut, Plain . . . . .	3	D
		- - - * - - -		
-52	635158-12.00	. . Hose Assembly. . . . .	1	D
-53	635158-10.00	. . Hose Assembly. . . . .	1	D
-54	635158-40.00	. . Hose Assembly. . . . .	1	D
	631351A6	. Fuel Manifold Valve Assembly . . . . .	1	D
-55	631720	. . Elbow, 90 Degree, Pressure Connector . . . . .	1	D
-56	628437	. . Elbow, 90 Degree, Fuel Inlet . . . . .	1	D
-57	627331	. . Elbow, 45 Degree, Cylinder 1-2-5-6 . . . . .	4	D
-58	AN780-2	. . Nipple, Union, Cylinder 3-4 . . . . .	2	D
-59	634011	. . Bracket, Fuel Manifold-to-Crankcase. . . . .	1	D
ATTACHING PARTS				
-60	AN500-10-5	. . Screw . . . . .	2	D
-61	AN936A10	. . Washer . . . . .	2	D
		- - - * - - -		

FIGURE & INDEX NO.	PART NUMBER	DESCRIPTION							UNITS PER ASS'Y.	USABLE ON CODE
		1	2	3	4	5	6	7		
33-62	631330	..	..	..	..	..	..	..	1	D
-63	626557	..	..	..	..	..	..	..	1	D
-64	630184	..	..	..	..	..	..	..	1	D
-65	626553	..	..	..	..	..	..	..	1	D
ATTACHING PARTS										
-66	AN500A8-10	..	..	..	..	..	..	..	4	D
-67	628154	..	..	..	..	..	..	..	2	D
	628153	..	..	..	..	..	..	..	2	D
	628152	..	..	..	..	..	..	..	2	D
-68	628301	..	..	..	..	..	..	..	1	D
	628295	..	..	..	..	..	..	..	1	D
-69	626577-2	..	..	..	..	..	..	..	6	D
-70	627335D13	* ..	..	..	..	..	..	..	6	D

NOTE: (\*) Check dash number on old nozzle for complete part number.

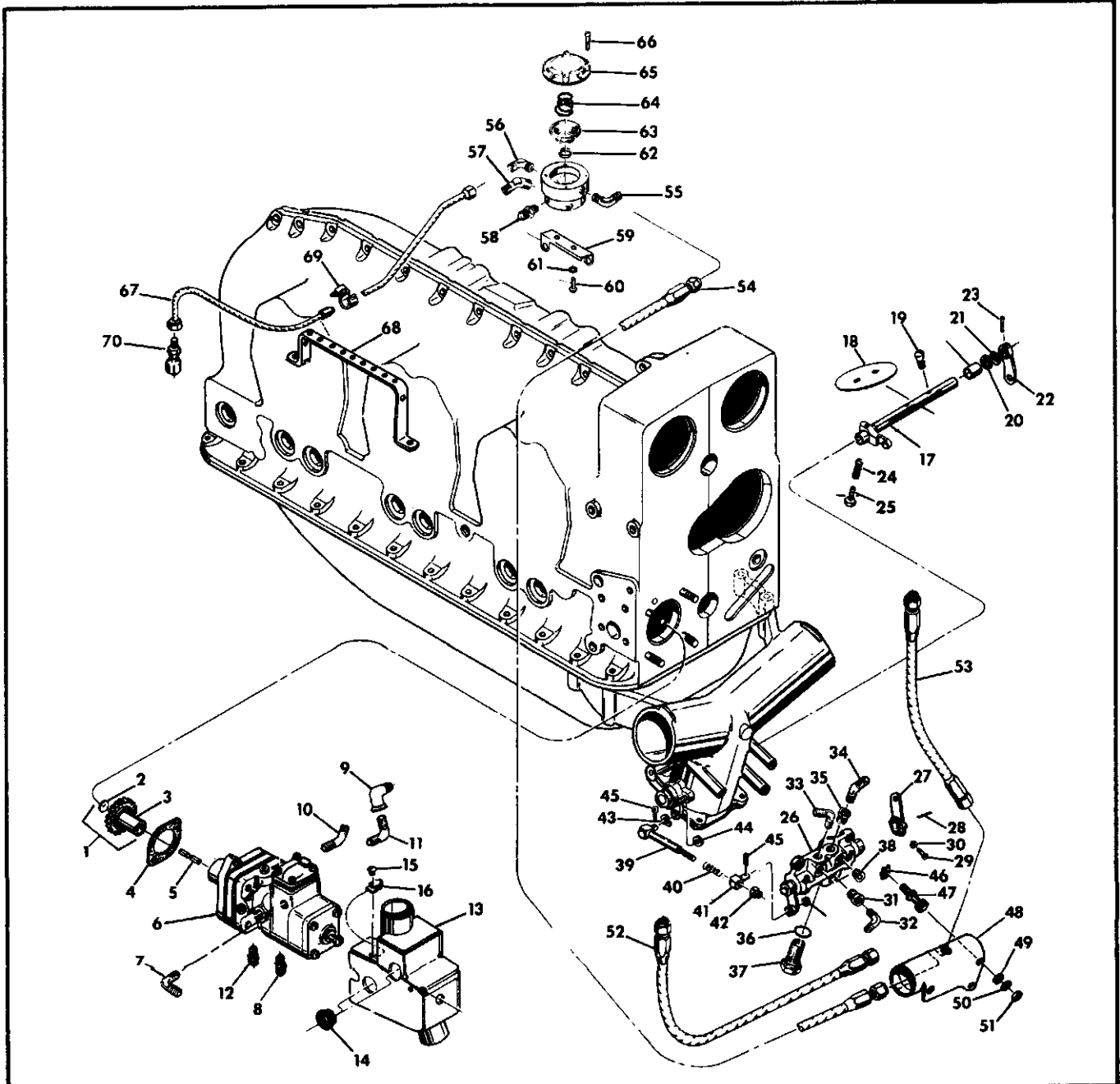

Figure 33. Fuel Injection System.

FIGURE & INDEX NO.	PART NUMBER	DESCRIPTION	UNITS PER ASS'Y.							USABLE ON CODE	
			1	2	3	4	5	6	7		
34- 1	534863	\$ Gasket, Adapter-to-Crankcase . . . . .								2	All
- 2	534861	Adapter Assembly, Magneto & Accessory Drive . . . . .								2	All
ATTACHING PARTS											
- 3	2473	Washer, Plain . . . . .								6	All
- 4	401507	Washer, Plain . . . . .								2	All
- 5	AN936A516	Washer, Lock . . . . .								6	All
- 6	AN936A616	Washer, Lock . . . . .								2	All
- 7	AN315-5R	Nut, Plain, Hex, 5/16-24 . . . . .								6	All
- 8	2441	Nut, Plain, Hex, 3/8-24 . . . . .								2	All
* - - -											
- 9	No Number	. Adapter, Magneto & Accessory Drive . . . . .								NS	All
-10	534742	. Bushing, Adapter . . . . .								1	All
-11	25102	\$ . Seal, Oil . . . . .								1	All
-12	25008	† . Stud, 1/4 X 1-3/8 In. Lg. . . . .								4	All
-13	629076	Gear Assembly, Magneto & Accessory Drive . . . . .								2	AEFJKL
-13	629422	Gear Assembly, Magneto & Accessory Drive . . . . .								2	BCD
-14	No Number	. Gear, Drive . . . . .								NS	All
-15	629077	. Sleeve, Drive Gear . . . . .								1	All
-16	531178	Retainer, Magneto Drive Coupling . . . . .								2	All
-17	531179	Bushing, Drive Coupling, Rubber . . . . .								4	All
-18	AN4045-1	\$ Gasket, Adapter-to-Cover . . . . .								2	All
-19	633068	Cover, Accessory Drive . . . . .								2	All
ATTACHING PARTS											
-20	2472	Washer, Plain . . . . .								8	All
-21	AN936A616	Washer, Lock . . . . .								8	All
-22	AN315-4R	Nut, Plain, Hex, 1/4-28 . . . . .								8	All
* - - -											

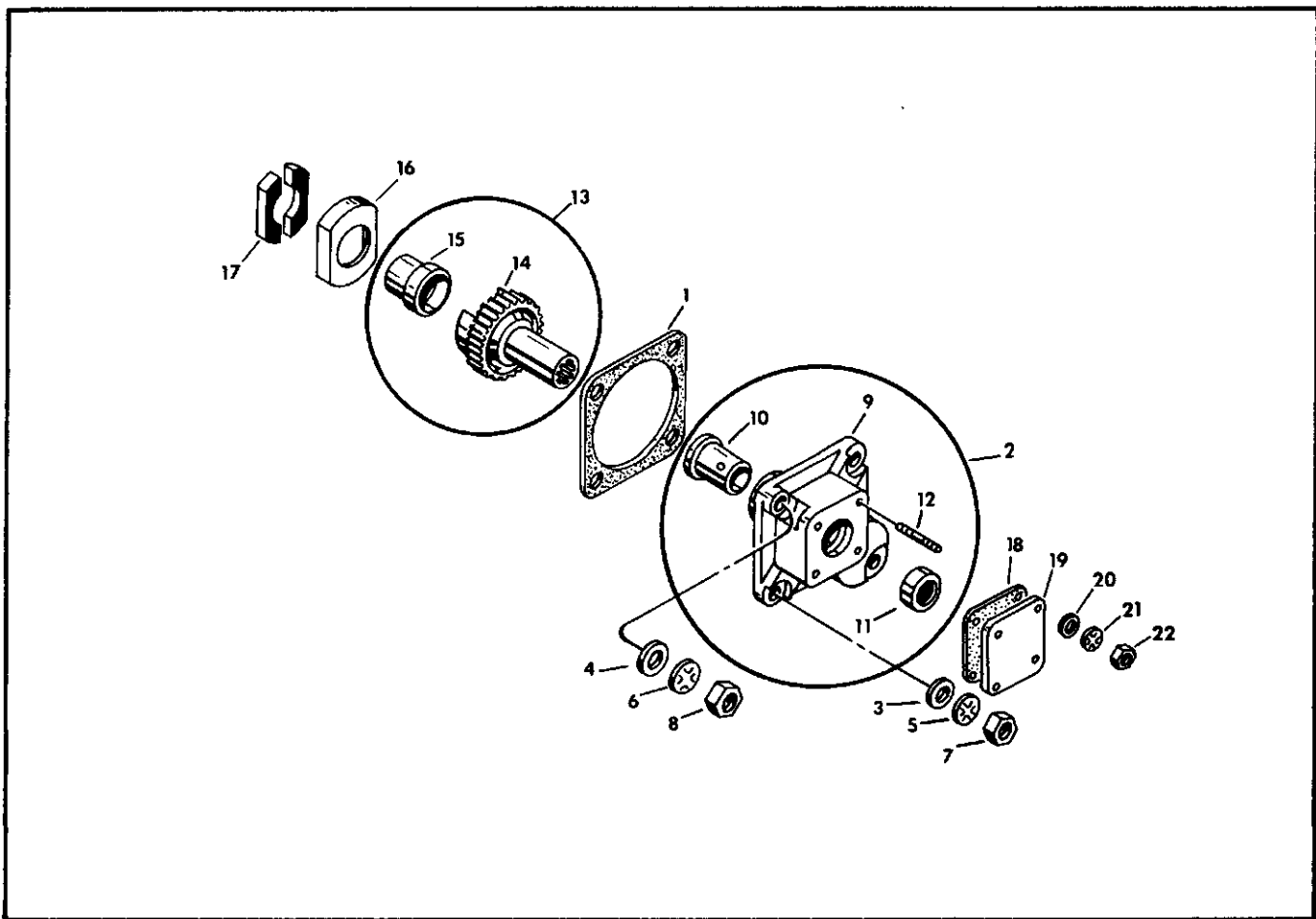

Figure 34. Magneto and Accessory Drive Assembly.

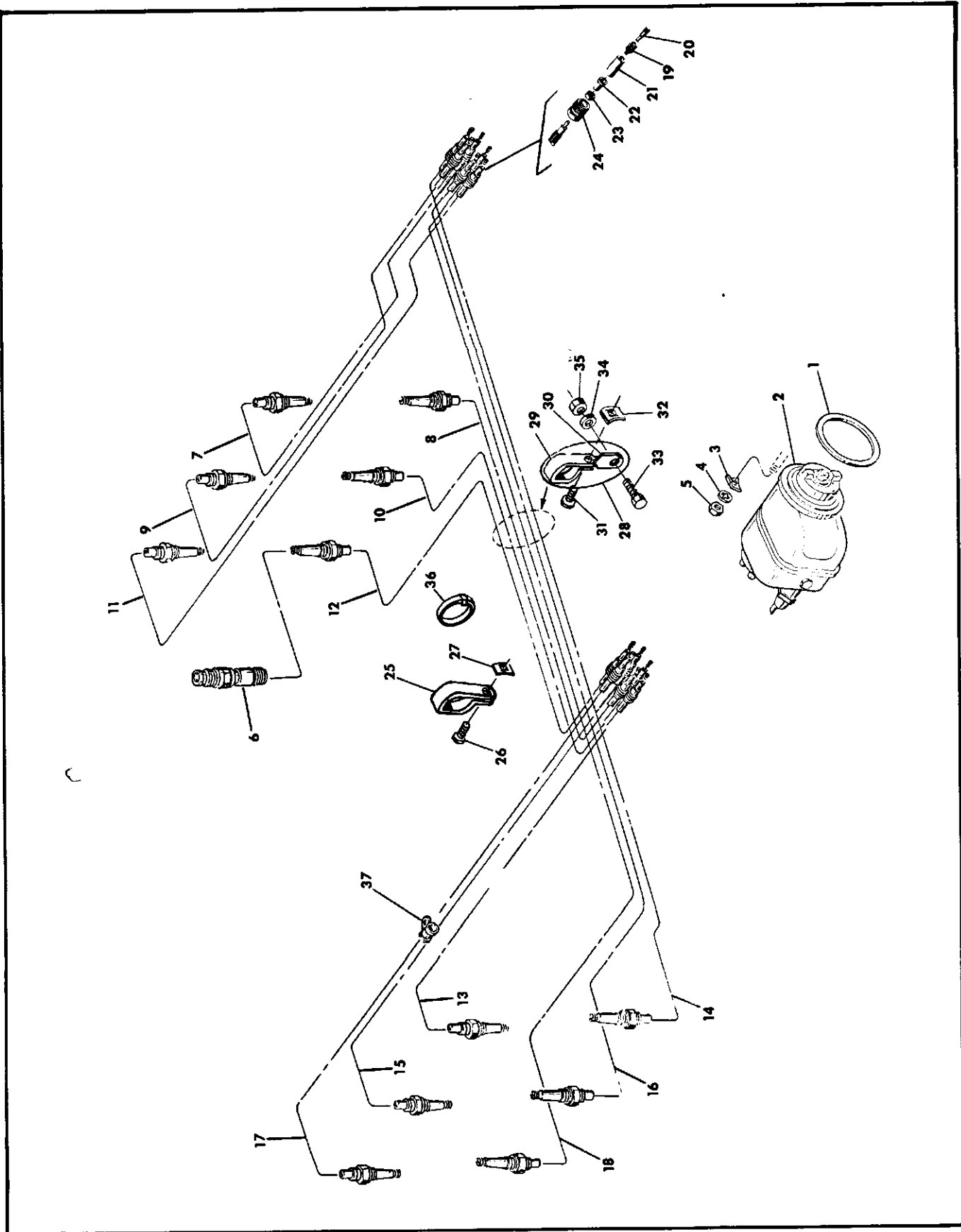

Figure 35. Ignition System.

FIGURE & INDEX NO.	PART NUMBER	DESCRIPTION	UNITS	USABLE
			PER ASS'Y.	ON CODE
		1 2 3 4 5 6 7		
35- 1	534750	\$ Gasket, Magneto-to-Crankcase . . . . .	2	ADFJL
- 2	625765	Magneto Assembly, Slick Electro Model No. 662 . . . . .	2	ADFJL
		ATTACHING PARTS		
- 3	535847	Washer, Magneto Holding . . . . .	4	ADFJL
- 4	AN936A516	Washer, Lock . . . . .	4	ADFJL
- 5	AN315-5R	Nut, Plain, Hex . . . . .	4	ADFJL
		- - - * - - -		
- 6	630533	Spark Plug, AC-No. 27 . . . . .	12	ADFJL
	633311	Harness Assembly, Right and Left Magneto . . . . .	1	ADFJL
- 7	633580	* . Cable Assembly, No. 1 Upper 19 In. Lg. . . . .	1	ADFJL
- 8	633579	* . Cable Assembly, No. 1 Lower 38 In. Lg. . . . .	1	ADFJL
- 9	633580	* . Cable Assembly, No. 3 Upper 22 In. Lg. . . . .	1	ADFJL
-10	633579	* . Cable Assembly, No. 3 Lower 42 In. Lg. . . . .	1	ADFJL
-11	633579	* . Cable Assembly, No. 5 Upper 29 In. Lg. . . . .	1	ADFJL
-12	633579	* . Cable Assembly, No. 5 Lower 49 In. Lg. . . . .	1	ADFJL
-13	633580	* . Cable Assembly, No. 2 Upper 21 In. Lg. . . . .	1	ADFJL
-14	633579	* . Cable Assembly, No. 2 Lower 41 In. Lg. . . . .	1	ADFJL
-15	633580	* . Cable Assembly, No. 4 Upper 17 In. Lg. . . . .	1	ADFJL
-16	633579	* . Cable Assembly, No. 4 Lower 38 In. Lg. . . . .	1	ADFJL
-17	633580	* . Cable Assembly, No. 6 Upper 25 In. Lg. . . . .	1	ADFJL
-18	633579	* . Cable Assembly, No. 6 Lower 42 In. Lg. . . . .	1	ADFJL
-19	633586	. Spring . . . . .	1	ADFJL
-20	633585	. Screw, Electro. . . . .	1	ADFJL
-21	633584	. Sleeve, Insulating . . . . .	1	ADFJL
-22	633583	. Ferrule, Drive. . . . .	1	ADFJL
-23	633582	. Washer . . . . .	1	ADFJL
-24	633581	. Nut, Magneto End . . . . .	1	ADFJL
-25	636692	. Clamp Assembly . . . . .	2	ADFJL
-26	632105	. Screw . . . . .	2	ADFJL
-27	629837	. Nut, Tinnerman . . . . .	2	ADFJL
-28	636689	. Clamp Assembly . . . . .	1	ADFJL
-29	636690	. . Clamp . . . . .	1	ADFJL
-30	636691	. . Bracket . . . . .	1	ADFJL
-31	632105	. Screw . . . . .	1	ADFJL
-32	629837	. Nut, Tinnerman . . . . .	1	ADFJL
-33	AN501-10-8	. Screw . . . . .	1	ADFJL
-34	AN936A10	. Washer, Lock . . . . .	1	ADFJL
-35	MS20365-1032A	. Nut, Elastic Stop . . . . .	1	ADFJL
-36	636688	. Ty-Rap . . . . .	10	ADFJL
-37	636684	. Clamp . . . . .	12	ADFJL

NOTE: (\*) Replacement leads are sold in two lengths only, with magneto end not terminated.  
Part Number 633580 cable assembly for leads up to 28 inches long.  
Part Number 633579 cable assembly for leads up to 50 inches long.

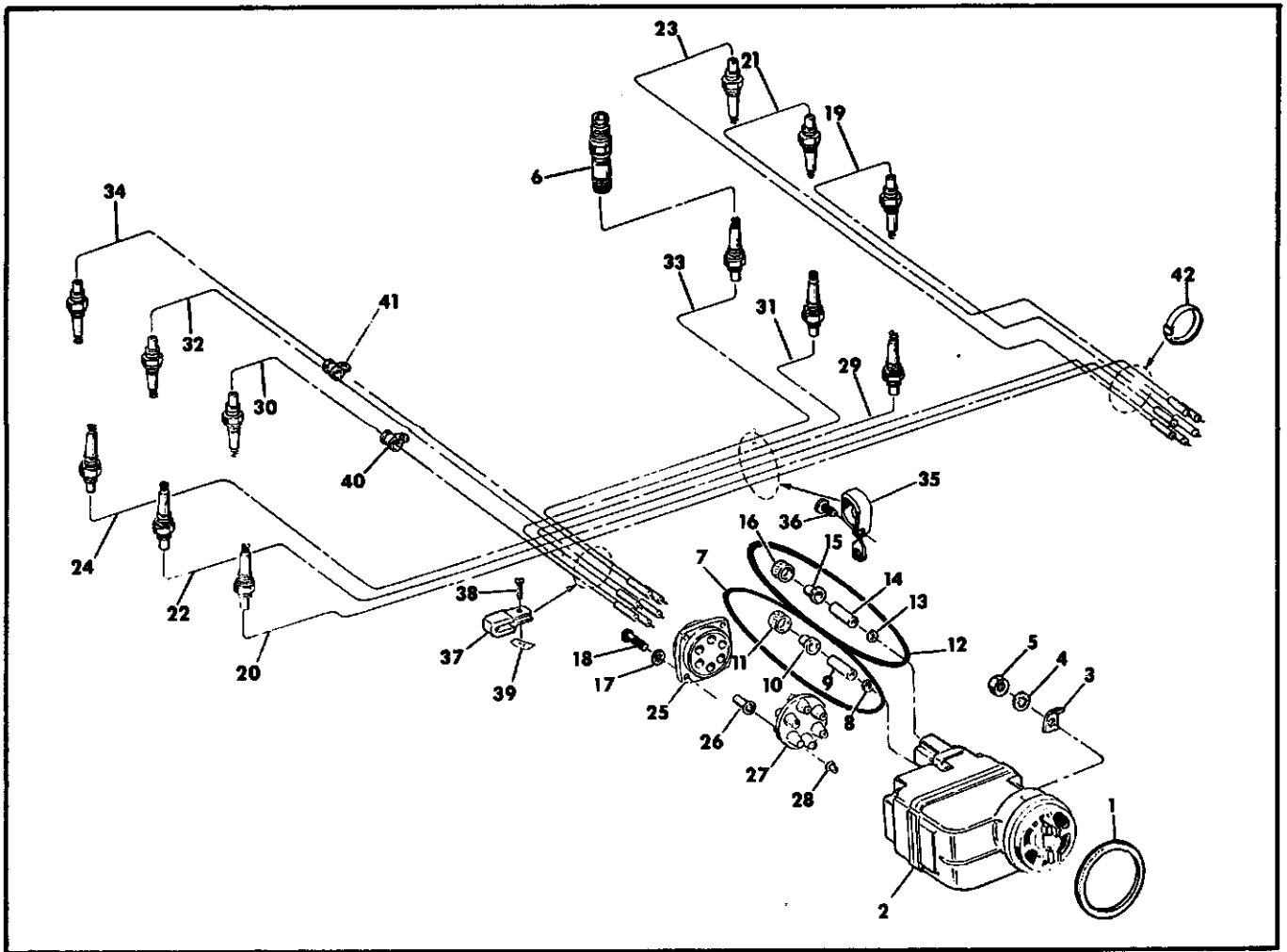

Figure 36. Ignition System.

TABULATED DATA

		B	C	E & K
RIGHT MAGNETO	1T	15.250	16.28	15.250
	2B	39.060	39.45	39.060
	3T	20.060	20.84	20.060
	4B	35.690	37.07	35.690
	5T	28.060	29.44	28.060
	6B	42.060	43.17	42.060
LEFT MAGNETO	1B	35.690	37.55	35.690
	2T	22.060	21.61	22.000
	3B	40.560	41.94	40.560
	4T	18.940	17.98	17.190
	5B	47.560	48.67	47.560
	6T	26.560	25.53	23.060

FIGURE & INDEX NO.	PART NUMBER	DESCRIPTION	UNITS	USABLE
			PER ASS'Y.	ON CODE
		1 2 3 4 5 6 7		
36- 1	534750	\$ Gasket, Magneto-to-Crankcase . . . . .	2	BCEK
- 2	628472	Magneto Assembly, L. H. Model S6RN-201 . . . . .	1	BE
		Bendix Scintilla No. 10-163020-3		
- 2	632958	Magneto Assembly, L. H. Model S6RN-1201 . . . . .	1	C
		Bendix Scintilla No. 10-349220-1		
- 2	628473	Magneto Assembly, R. H. Model S6RN-205 . . . . .	1	BE
		Bendix Scintilla No. 10-163060-1		
- 2	632959	Magneto Assembly, R. H. Model S6RN-1205 . . . . .	1	C
		Bendix Scintilla No. 10-349260-1		
- 2	631237	Magneto Assembly (Left & Right). . . . .	2	K
		Bendix Scintilla No. 10-7902-10		
		ATTACHING PARTS		
- 3	535847	Washer, Magneto Holding . . . . .	4	BCEK
- 4	AN936A516	Washer, Lock . . . . .	4	BCEK
- 5	AN315-5R	Nut, Plain, Hex . . . . .	4	BCEK
		* - - - - *		
- 6	628036	Spark Plug, Champion No. RHB33E . . . . .	12	BCE
- 6	630533	Spark Plug . . . . .	12	K
- 7	628739	Kit, Retard Terminal, L. H. Magneto . . . . .	1	BCEK
- 8	629010	Washer, Plain . . . . .	1	BCEK
- 9	629009	Bushing, Insulating . . . . .	1	BCEK
-10	629008	Bushing, Shouldered . . . . .	1	BCEK
-11	629007	Nut, Coupling, 3/8-32 . . . . .	2	BCEK
-12	628740	Kit, Ground Terminal, L. H. & R. H. Magneto . . . . .	1	BCEK
-13	629010	Washer, Plain . . . . .	1	BCEK
-14	629009	Bushing, Insulating . . . . .	1	BCEK
-15	629008	Bushing, Shouldered . . . . .	1	BCEK
-16	629011	Nut, Coupling, 7/16-28 . . . . .	1	B
	632992	Harness Assembly, Complete . . . . .	1	C
	633051	Harness Assembly, Complete . . . . .	1	EK
	633005	Harness Assembly, Complete . . . . .	1	EK
		ATTACHING PARTS		
-17	AN935-10	Washer, Lock . . . . .	8	BCEK
-18	AN501-10-10	Screw . . . . .	8	BCEK
		* - - - - *		
	No Number	Harness Assembly, Right Magneto . . . . .	NS	BCEK
-19	633008-127	** Cable Assembly, No. 1 Upper (For Lengths See Tab Data) . . . . .	1	BCEK
-20	633008-127	** Cable Assembly, No. 2 Lower (For Lengths See Tab Data) . . . . .	1	BCEK
-21	633008-127	** Cable Assembly, No. 3 Upper (For Lengths See Tab Data) . . . . .	1	BCEK
-22	633008-127	** Cable Assembly, No. 4 Lower (For Lengths See Tab Data) . . . . .	1	BCEK
-23	633008-127	** Cable Assembly, No. 5 Upper (For Lengths See Tab Data) . . . . .	1	BCEK
-24	633008-127	** Cable Assembly, No. 6 Lower (For Lengths See Tab Data) . . . . .	1	BCEK
-25	633009	* Plate, Cable Outlet . . . . .	6	BCEK
-26	629498	* Ferrule, Cable . . . . .	1	BCEK
-27	629496	* Grommet, Plate . . . . .	6	BCEK
-28	629495	* Eyelet, Cable Contact . . . . .	NS	BCEK
	No Number	Harness Assembly, Left Magneto . . . . .	1	BCEK
-29	633008-127	** Cable Assembly, No. 1 Lower (For Lengths See Tab Data) . . . . .	1	BCEK
-30	633008-127	** Cable Assembly, No. 2 Upper (For Lengths See Tab Data) . . . . .	1	BCEK
-31	633008-127	** Cable Assembly, No. 3 Lower (For Lengths See Tab Data) . . . . .	1	BCEK
-32	633008-127	** Cable Assembly, No. 4 Upper (For Lengths See Tab Data) . . . . .	1	C
-33	633008-128	** Cable Assembly, No. 5 Lower (For Lengths See Tab Data) . . . . .	1	BEK
-33	633008-127	** Cable Assembly, No. 5 Lower (For Lengths See Tab Data) . . . . .	1	BCEK
-34	633008-127	** Cable Assembly, No. 6 Upper (For Lengths See Tab Data) . . . . .	1	BCEK
-35	635982	Clamp Assembly . . . . .	1	BCEK
-36	635987	Screw . . . . .	1	BCEK
-37	631739	Clamp Assembly . . . . .	1	BCEK
-38	632105	Screw . . . . .	2	BCEK
-39	629837	Nut, Speed . . . . .	13	BCEK
-40	632106	Clamp . . . . .	2	BC
-41	631737	Clamp . . . . .	9	BCEK
-42	629494	Strap . . . . .		

NOTES: (#) Service Sleeve - Use Thomas & Betts Crimping Tool #WT-217.  
 (\*) Index Nos. 25 through 28 are applicable to Right and Left Harnesses.  
 (\*\*) Replacement leads are sold in two lengths only with magneto end not terminated.  
 633008-127 Cable assembly for leads up to 48" long.  
 633008-128 Cable assembly for leads up to 72" long.

## SECTION III

## OVERSIZE AND UNDERSIZE PARTS LIST

PART NO.	NAME	DESCRIPTION	PART NO.	NAME	DESCRIPTION
22319P003	Stud	.003" OS on PD	401870P003	Stud	.003" OS on PD
22319P006	Stud	.006" OS on PD	401870P007	Stud	.007" OS on PD
22319P009	Stud	.009" OS on PD	401870P012	Stud	.012" OS on PD
25008P003	Stud	.003" OS on PD	401885P003	Stud	.003" OS on PD
25008P006	Stud	.006" OS on PD	401885P007	Stud	.007" OS on PD
25008P009	Stud	.009" OS on PD	401885P012	Stud	.012" OS on PD
350997P0015	Bushing - C/shaft	.0015" OS on OD	401893P003	Stud	.003" OS on PD
350997P003	Bushing - C/shaft	.003" OS on OD	401893P007	Stud	.007" OS on PD
350997P005	Bushing - C/shaft	.005" OS on OD	401893P012	Stud	.012" OS on PD
35967P005	Insert	.005" OS on OD	401927P003	Stud	.003" OS on PD
35967P010	Insert	.010" OS on OD	401927P007	Stud	.007" OS on PD
35967P015	Insert	.015" OS on OD	401927P012	Stud	.012" OS on PD
35967P020	Insert	.020" OS on OD	401932P003	Stud	.003" OS on PD
35967P030	Insert	.030" OS on OD	401932P007	Stud	.007" OS on PD
350998P0015	Bushing - C/shaft	.0015" OS on OD	401932P012	Stud	.012" OS on PD
350998P003	Bushing - C/shaft	.003" OS on OD	401936P003	Stud	.003" OS on PD
350998P005	Bushing - C/shaft	.005" OS on OD	401936P007	Stud	.007" OS on PD
401800P003	Stud	.003" OS on PD	401936P012	Stud	.012" OS on PD
401800P007	Stud	.007" OS on PD	401944P003	Stud	.003" OS on PD
401800P012	Stud	.012" OS on PD	401944P007	Stud	.007" OS on PD
401801P003	Stud	.003" OS on PD	401944P012	Stud	.012" OS on PD
401801P007	Stud	.007" OS on PD	401962P003	Stud	.003" OS on PD
401801P012	Stud	.012" OS on PD	401962P007	Stud	.007" OS on PD
401804P003	Stud	.003" OS on PD	401962P012	Stud	.012" OS on PD
401804P007	Stud	.007" OS on PD	401963P003	Stud	.003" OS on PD
401804P012	Stud	.012" OS on PD	401963P007	Stud	.007" OS on PD
401808P003	Stud	.003" OS on PD	401963P012	Stud	.012" OS on PD
401808P007	Stud	.007" OS on PD	401965P003	Stud	.003" OS on PD
401808P012	Stud	.012" OS on PD	401965P007	Stud	.007" OS on PD
401814P003	Stud	.003" OS on PD	401965P012	Stud	.012" OS on PD
401814P007	Stud	.007" OS on PD	401977P003	Stud	.003" OS on PD
401814P012	Stud	.012" OS on PD	401977P007	Stud	.007" OS on PD
401863P003	Stud	.003" OS on PD	401977P012	Stud	.012" OS on PD
401863P007	Stud	.007" OS on PD	402034P003	Stud	.003" OS on PD
401863P012	Stud	.012" OS on PD	402034P007	Stud	.007" OS on PD
401842P003	Stud	.003" OS on PD	402034P012	Stud	.012" OS on PD
401842P007	Stud	.007" OS on PD	402127P003	Stud	.003" OS on PD
401842P012	Stud	.012" OS on PD	402127P007	Stud	.007" OS on PD
401852P003	Stud	.003" OS on PD	402127P012	Stud	.012" OS on PD
401852P007	Stud	.007" OS on PD	402129P003	Stud	.003" OS on PD
401852P012	Stud	.012" OS on PD	402129P007	Stud	.007" OS on PD
401860P003	Stud	.003" OS on PD	402129P012	Stud	.012" OS on PD
401860P007	Stud	.007" OS on PD	402131P003	Stud	.003" OS on PD
401860P012	Stud	.012" OS on PD	402131P007	Stud	.007" OS on PD
401861P003	Stud	.003" OS on PD	402131P012	Stud	.012" OS on PD
401861P007	Stud	.007" OS on PD	402151P003	Stud	.003" OS on PD
401861P012	Stud	.012" OS on PD	402151P007	Stud	.007" OS on PD
401863P003	Stud	.003" OS on PD	402151P012	Stud	.012" OS on PD
401863P007	Stud	.007" OS on PD			
401863P012	Stud	.012" OS on PD			



OVERSIZE AND UNDERSIZE PARTS LIST (CONT'D)

PART NO.	NAME	DESCRIPTION	PART NO.	NAME	DESCRIPTION
402153P003	Stud	.003" OS on PD	629726P020	Camshaft	.020" OS on OD
402153P007	Stud	.007" OS on PD			
402153P012	Stud	.012" OS on PD	630046P005	Pin - Piston	.005" OS on OD
402158P003	Stud	.003" OS on PD	630464M010	Bearing - C/shaft	.010" US on ID
402158P007	Stud	.007" OS on PD			
402158P012	Stud	.012" OS on PD	630591P005	Insert	.005" OS on OD
402159P003	Stud	.003" OS on PD	630591P010	Insert	.010" OS on OD
402159P007	Stud	.007" OS on PD	630591P015	Insert	.015" OS on OD
402159P012	Stud	.012" OS on PD	630591P020	Insert	.020" OS on OD
			630591P030	Insert	.030" OS on OD
402711P003	Stud	.003" OS on PD	630752P005	Ring - Piston	.005" OS on OD
402711P007	Stud	.007" OS on PD	630752P010	Ring - Piston	.015" OS on OD
402711P012	Stud	.012" OS on PD	630752P015	Ring - Piston	.015" OS on OD
524183P003	Stud	.003" OS on PD	630753P005	Ring - Piston	.005" OS on OD
524183P007	Stud	.007" OS on PD	630753P010	Ring - Piston	.010" OS on OD
524183P012	Stud	.012" OS on PD	630753P015	Ring - Piston	.015" OS on OD
531590P003	Stud	.003" OS on PD	630789M010	Bearing - C/shaft	.010" US on ID
531590P007	Stud	.007" OS on PD			
531590P012	Stud	.012" OS on PD	631475P010	Piston	.010" OS on OD
535661P020	Camshaft	.020" OS on OD	631475P015	Piston	.015" OS on OD
535956P003	Stud	.003" OS on PD	631496P005	Guide - Valve	.005" OS on OD
535956P006	Stud	.006" OS on PD	631496P010	Guide - Valve	.010" OS on OD
535956P009	Stud	.009" OS on PD	631496P015	Guide - Valve	.015" OS on OD
			631496P020	Guide - Valve	.020" OS on OD
536563P005	Dowel	.005" OS on OD	631496P030	Guide - Valve	.030" OS on OD
538404P003	Stud	.003" OS on PD	631729P005	Ring - Piston	.005" OS on OD
538404P006	Stud	.006" OS on PD	631729P010	Ring - Piston	.010" OS on OD
538404P009	Stud	.009" OS on PD	631729P015	Ring - Piston	.015" OS on OD
628750M010.	Bearing - C/Rod	.010" US on ID	631867P003	Stud	.003" OS on PD
			631867P006	Stud	.006" OS on PD
			631867P012	Stud	.009" OS on PD
629401P005	Ring - Piston	.005" OS on OD			
629401P010	Ring - Piston	.010" OS on OD			
629401P015	Ring - Piston	.015" OS on OD			

SECTION IV  
REPAIR PARTS SETS AND MATERIALS

PART NUMBER	DESCRIPTION	SIZE	CODE
20705-1	Gasket Paste - Tite Seal, lightweight	1 oz. tube	ALL
632424A1	Gasket Set - Complete Overhaul	Standard	ADEF
632429A1	Gasket Set - Complete Overhaul	Standard	B
632430A1	Gasket Set - Complete Overhaul	Standard	C
630752A2	Ring Set - Complete Engine	Standard	ALL
630752A2P005	Ring Set - Complete Engine	.005" OS on OD	ALL
630752A2P010	Ring Set - Complete Engine	.010" OS on OD	ALL
630752A2P015	Ring Set - Complete Engine	.015" OS on OD	ALL
630464A1	Bearing Set - Crankshaft	Standard	ADEF
630464A1M010	Bearing Set - Crankshaft	.010" US on ID	ADEF
635439A2	Bearing Set - Crankshaft	Standard	BC
630789A2M010	Bearing Set - Crankshaft	.010" US on ID	BC
626531-1	Enamel - Gold, Engine	1 Quart	ALL
626531-2	Enamel, Gold, Engine	1 Gallon	ALL
535011	Lockwire - 0.040 in. dia. steel	Order by the foot	ALL

**SECTION V**  
**NUMERICAL PARTS LIST**

PART NUMBER	FIGURE & INDEX	QTY PER ASSY
AN100043	14-42	1
	15-36	1
AN123861	2-15	1
	3-37	1
	5-32	1
AN123862	2-19	2
	5-08	2
	16-23	1
AN123902	17-24	1
AN123962	8-30	1
AN123965	7-26	1
AN280H405	9-05	1
	10-06	1
	16-11	1
	16-30	1
	17-20	1
AN315-4R	6-18	2
	6-32	2
	14-45	4
	15-23	6
	15-39	4
	33-51	3
	34-22	8
AN315-5R	2-14	12
	2-28	1
	2-34	2
	3-13	1
	3-31	4
	5-16	1
	5-22	2
	5-26	12
	6-13	4
	6-27	1
	16-05	2
	17-04	2
	17-28	5
	18-08	2
	20-09	2
	23-09	1
	28-44	1
	34-07	6
	35-05	4
	36-05	4
AN315-6R	16-45	2
AN316-9	16-34	1
AN356-820	2-10	3
	3-10	1
	5-29	16
	13-05	12
AN364-428	28-36	1
AN381-25-10	11-06	12
AN4-13A	5-39	6
AN4-15A	5-39	5
AN4-17A	24-08	1
AN4-26A	28-35	1
	29-30	1

PART NUMBER	FIGURE & INDEX	QTY PER ASSY
AN4-7A	29-22	1
AN4045-1	14-41	1
	15-35	1
	34-18	2
AN5-11A	5-14	1
	5-23	9
AN5-12A	2-11	9
	2-26	1
	5-14	1
AN5-14A	2-31	2
AN5-15A	18-06	2
	20-06	1
AN5-17A	20-05	1
AN5-20A	18-05	1
AN500-10-5	30-61	2
	31-53	2
	32-54	2
	33-60	2
AN500-10-10	33-29	1
AN500A10-4	2-36	2
AN500A416-8	3-34	3
AN500A8-10	30-67	4
	31-59	4
	32-60	4
	33-66	4
AN501-10-6	3-44	1
AN501-10-8	35-33	1
AN501-10-10	36-18	8
AN526-10-24-4	30-17	2
	33-15	1
AN737 TW46	27-14	1
	28-18	1
	29-14	1
AN737 TW48	28-18	1
AN74A3	24-05	2
	26-05	2
AN74A4	24-04	2
	26-04	2
AN75A6	18-10	1
	20-11	1
AN75A10	20-16	1
AN75A15	18-15	1
	27-20	2
AN75A26	27-21	2
AN780-2	30-59	2
	31-51	2
	32-52	2
	33-58	2
AN900-10	1-26	1
	4-29	1
	24-09	1
	24-17	2
	25-11	2
	26-11	1
AN900-12	24-10	1
	25-03	1

PART NUMBER	FIGURE & INDEX	QTY PER ASSY
AN900-14	14-55	1
AN900-18	14-15	1
	15-13	2
AN900-22	15-42	1
AN900-28	14-51	1
AN932-2	30-39	2
	31-26	2
	32-32	2
	33-38	2
AN932C2	4-25	2
AN935-10	36-17	8
AN936A10	3-24	4
	3-46	1
	6-35	4
	30-62	2
	31-54	2
	32-55	2
	33-61	2
	35-34	1
AN936A416	3-19	2
	6-17	2
	6-31	2
	13-34	48
	14-03	7
	14-25	6
	14-28	2
	14-44	4
	15-03	1
	15-22	6
	15-38	4
	22-04	5
	22-10	12
	27-05	24
	28-05	24
	28-39	2
	29-05	24
	29-21	1
	29-29	2
	29-35	2
	30-51	3
	31-44	3
	32-45	1
	33-50	3
AN936A516	2-13	12
	2-27	1
	2-33	2
	3-12	1
	3-15	1
	3-30	4
	5-15	1
	5-21	2
	5-25	12
	5-31	5
	6-05	2
	6-12	4
	6-26	1
	16-03	3
	16-28	3
	16-38	2
	17-03	2
	17-27	5
	23-08	1
	28-43	1
	34-05	6
	35-04	4
	36-04	4

PART NUMBER	FIGURE & INDEX	QTY PER ASSY
AN936A616	2-21	1
	3-04	16
	5-10	2
	6-23	9
	15-47	3
	16-44	2
	23-05	4
	25-16	12
	34-06	2
	34-21	8
AN960-10L	3-23	4
	6-34	4
AN960-416L	6-30	2
AN960-516	2-12	12
	2-25	2
	2-32	2
	27-19	4
AN960-516L	26-08	28
AN960-616L	15-46	3
	25-15	12
	16-32	1
AN960C916	31-	1
EQ5965B	32-	1
EQ5966C	30-	1
EQ5991A	33-	1
EQ6085D	13-10	24
MS122121	4-05	9
MS122122	1-05	5
MS122162	4-05	5
MS20073-05.25	5-36	4
MS20365-1032A	30-43	1
	31-36	1
	32-36	1
	33-42	1
	35-35	1
MS24665-302	19-12	1
MS9021-017	6-19	2
	23-03	2
MS9021-038	16-41	1
	17-29	1
MS9021-210	6-01	1
M330S208	29-25	1
X13041	16-13	1
	17-22	1
X1454	7-22	1
	8-23	1
X1473	14-17	1
	15-15	1
X604	31-24	1
	32-25	1
13XX1896	3-25	4
	3-47	1
	6-36	4
13XX202B	21-13	1
	24-15	28
	25-07	30
	26-09	28
13XX260	33-30	1
13XX299	16-33	1
20202	5-03	4
2024	1-21	1
	14-08	1
	27-22	1
2025	1-22	4
	4-27	1
	23-14	1

PART NUMBER	FIGURE & INDEX	QTY PER ASSY
2026	22-06	1
20522	5-40	12
	13-33	48
	14-02	7
	14-24	6
	14-27	2
	15-02	1
	15-21	6
	22-03	5
	24-03	2
	26-03	2
	27-04	24
	28-04	24
	28-38	2
	29-04	24
	30-50	3
	31-43	3
	32-44	1
	33-49	3
20655	14-50	4
	15-34	4
21007	13-26	6
	13-29	6
21163	14-40	1
	15-41	1
21208A1	14-38	1
	15-	1
21247	13-37	24
22319	15-26	4
22535	3-28	4
	6-10	4
2265	4-28	1
	24-11	1
	25-04	1
	25-12	1
22661	18-13	1
	20-14	1
	28-27	1
	29-23	1
	29-31	1
22786	21-07	2
22910	14-49	4
	15-33	4
23024	15-08	2
23890	29-34	2
24239	2-20	2
	5-09	2
	21-08	2
	28-29	1
2437	3-20	2
	14-04	7
	14-26	6
	14-29	2
	15-04	1
	22-05	5
	22-16	1
	28-40	2
	28-51	2
	29-20	1
	29-28	2
	30-52	3
	31-45	3
	32-46	1

PART NUMBER	FIGURE & INDEX	QTY PER ASSY
2441	2-23	1
	3-05	16
	5-11	2
	6-24	9
	15-48	3
	17-32	2
	21-06	1
	23-06	4
	25-17	12
	34-08	2
2457	31-23	1
	32-26	1
2471	3-45	1
	14-48	4
	15-32	4
2472	34-20	8
2473	2-17	4
	3-14	1
	3-29	4
	5-13	2
	5-30	5
	5-37	8
	6-04	2
	6-11	4
	6-25	1
	13-22	12
	16-02	3
	16-27	3
	16-37	2
	17-02	2
	17-26	5
	18-07	2
	19-02	4
	20-08	1
	22-09	12
	23-07	1
	24-14	28
	25-06	30
	34-03	6
2474	6-22	9
	23-04	4
24764	2-38	6
	6-38	6
24802	13-20	24
24835	27-06	24
	28-06	24
	29-06	24
2500	30-46	2
	31-39	2
	32-39	2
	33-45	2
	34-12	8
25008	34-11	2
25102	2-05	12
25171	20-07	1
2555	18-09	2
2560	20-10	2
	17-33	2
2561	21-05	1
	3-11	1
2794	22-17	1
2886	2-07	12
2958	5-05	4
	13-03	36

PART NUMBER	FIGURE & INDEX	QTY PER ASSY
350997	7-05	8
	7-07	8
	8-05	8
	8-07	8
350998	7-02	8
	8-02	8
352117	7-	2
	8-	2
35967	13-12	6
35971	13-18	6
36151L	27-08	8
	28-08	8
	29-08	8
36151R	3-41	2
36181	3-27	1
	6-09	1
401506	2-16	1
401507	17-31	2
	34-04	2
401752	4-24	4
401800	14-06	1
401801	15-06	2
401804	4-06	2
401808	1-06	5
401814	1-07	4
	4-07	4
401816	14-33	1
401836	4-08	1
401842	4-09	2
401860	25-09	12
401861	1-08	16
401863	4-17	2
401870	1-09	2
401885	1-10	12
	4-10	10
401893	1-11	1
	7-18	2
	8-18	2
	13-09	24
	14-32	4
401927	4-11	3
401932	4-12	2
401936	4-13	5
401944	4-14	3
401962	4-15	1
401963	4-16	2
	14-07	1
401965	1-12	2
	4-14	2
401977	4-18	4
402034	4-19	1
402127	4-09	2
	16-06	2
	17-07	2
402129	1-13	2
402131	17-08	2
402151	1-14	2
	4-20	2
	17-06	3
402153	4-21	2
402158	1-15	5
402159	1-16	2
402711	15-27	1
	30-29	2
402941	4-26	4

PART NUMBER	FIGURE & INDEX	QTY PER ASSY
501867	16-18	1
	17-14	1
	30-47	3
	31-40	3
	32-40	2
	33-46	3
501868	21-16	1
502287	16-14	1
	17-23	1
	13-07	12
520112-1	17-17	1
521649	4-19	1
524183	10-02	1
524818	21-12	1
530346	24-16	28
	26-10	28
530658	11-03	6
531001	2-06	12
	5-04	4
	13-02	36
531083	3-26	1
	6-08	1
531178	34-16	2
531179	34-17	4
531378	14-31	1
	15-25	1
531547	14-43	4
	15-37	4
531548	1-04	2
531590	1-17	1
532377	30-15	1
532432	1-25	1
	24-18	2
	26-12	1
534337	30-18	2
	33-16	1
534487	13-30	24
534609	13-39	48
534610	13-40	24
534625	25-13	1
534632	3-	1
534639	13-	6
534655	9-06	1
534685	16-21	1
	17-16	1
534715	16-22	1
534728	3-18	1
534740	3-17	1
	6-15	1
534741	7-29	1
534742	34-10	2
534743	24-12	1
	25-05	1
	26-06	1
534750	35-01	2
	36-01	2
534757	7-	1
534775	16-31	1
534857	13-31	6
534861	34-02	2
534863	34-01	2
534938	16-24	1
534940	24-01	1
	26-01	1
534980	16-25	1

PART NUMBER	FIGURE & INDEX	QTY PER ASSY
535008	14-22	1
	15-19	1
535118	13-35	48
535631	22-11	12
535634	14-21	1
	15-18	1
535661	9-01	1
535662	9-03	1
535666	9-04	4
	28-42	1
535681	27-11	1
535810	2-22	1
535823	3-35	1
535847	35-03	4
	36-03	4
535885	14-46	1
	15-30	1
535887	14-47	1
	15-31	1
535900	14-22	1
	15-19	1
535908	14-36	1
	15-29	1
535956	1-18	4
	4-22	4
536033	13-25	12
	13-28	12
536038	13-37	24
536213	18-02	1
	20-02	1
536379	7-23	6
	8-24	6
536413	27-01	6
	28-01	6
	29-01	6
536421	7-21	1
536552	16-10	1
	17-19	1
536563	7-20	1
	8-20	1
536615	7-25	1
	8-29	1
536779	22-15	1
537019	13-23	12
537282	22-07	1
537296	13-38	12
537299	1-28	1
537312	22-02	1
537379	13-36	6
537505	1-29	1
537539	18-11	1
	20-12	1
	21-14	2
537629	32-42	1
537650	24-13	1
537690	30-45	2
	31-38	2
	32-38	2
	33-44	2
537721	1-03	1
537728	28-26	1
537738	16-26	1
537742	16-04	1
537745	16-01	1
537749	16-20	1

PART NUMBER	FIGURE & INDEX	QTY PER ASSY
537750	5-33	1
	16-29	1
	16-39	1
	21-15	1
	25-08	30
	28-46	2
537961	28-21	2
538076	9-07	1
538100	28-50	2
	29-24	1
538185	14-01	1
538304	13-42	12
538404	1-19	24
538468	28-31	2
	29-36	2
538470	29-32	1
538607	5-20	2
538650	2-29	1
	5-17	1
538727	14-52	1
538773	3-33	1
538801	3-33	1
538804	3-32	1
538944-5.31	5-01	1
538944-6.19	5-02	1
538944-8.88	2-02	2
538944-10.50	2-01	4
538949	2-30	1
	5-18	2
538969	3-09	1
	5-28	16
	13-04	12
538989	2-08	4
	3-08	1
538999	16-35	2
	16-40	1
539003	5-34	1
	28-21	2
539023	28-12	1
539050-9.81	2-03	1
539050-10.75	2-04	7
	5-06	8
539058	3-03	16
	16-43	2
539113	29-33	1
539114	28-32	1
	29-37	1
539291	3-	1
539374	5-19	1
	5-24	11
539374	28-30	1
539487	27-09	2
	28-09	4
	29-09	2
539518	3-01	4
539523	14-10	2
539547-31.19	18-01	1
539547-32.00	20-01	1
	21-17	1
539568	16-15	1
539571	27-10	10
	28-11	10
	29-10	10
539605	6-06	2

PART NUMBER	FIGURE & INDEX	QTY PER ASSY
539634	30-02	1
	33-02	1
539740	13-21	12
539742	13-	6
539785	16-16	1
539800	16-17	1
	17-13	1
539805	16-09	1
	17-21	1
539942	30-21	2
	31-13	2
	32-15	1
	33-19	2
539952	2-09	3
539959	30-38	1
	31-32	1
	32-31	1
	33-37	1
539988	13-13	6
625207	24-02	1
625219-2A13	33-26	1
625228	33-22	1
625238	31-16	1
	32-17	1
625303	22-01	1
625327	31-14	1
625327-1	30-23	2
	32-16	1
	33-21	1
625327-2	30-44	2
	31-37	2
	32-37	2
	33-43	2
625393	13-17	12
625457	30-22	2
	31-15	2
	32-18	2
	33-20	2
625539	33-39	1
625539A1	31-33	1
625542	31-35	1
	33-41	1
625600	33-17	1
625601	30-20	1
	31-12	1
	32-14	1
	33-18	1
625615	13-32	6
625765	35-02	2
625885	14-34	1
625886	14-23	1
626147	13-41	12
626183	30-37	1
	31-31	1
	32-30	1
	33-36	1
626189A	22-08	1
626486	31-61	1
626553	30-66	1
	31-58	1
	32-58	1
	33-65	1
626557	30-64	1
	31-56	1
	33-63	1

PART NUMBER	FIGURE & INDEX	QTY PER ASSY
626577-2	30-70	6
	31-62	6
	32-63	6
	33-69	6
626586	30-28	1
	31-20	1
	32-22	1
	33-25	1
626634	30-27	1
	30-41	1
	31-19	1
	31-34	1
	32-21	1
	32-34	1
	33-24	1
	33-40	1
626739	7-16	1
626813	30-26	2
	31-18	2
	32-20	2
	33-23	1
	33-28	1
626813-1	30-32	1
626879-1	30-16	3
	31-10	3
	32-12	1
	33-14	3
626889	7-17	2
	8-17	2
626890	7-27	1
626963	3-22	2
	6-33	2
626972-1	23-13	1
626974	7-24	1
	8-28	1
626990	2-35	1
627011	28-13	1
627068	18-19	1
627119	30-09	1
	30-12	1
	31-28	1
	33-09	1
627272	18-04	1
627276	18-14	1
627279	18-16	6
	20-17	4
627281	18-17	3
	20-18	2
627282	18-18	6
	20-19	4
627331	30-58	4
	31-50	4
	32-51	4
	33-57	4
627335D13	30-71	6
	31-63	6
	32-64	6
	33-70	6
627368	28-52	1
627377	18-03	1
	20-03	1
627378	31-57	1
	32-57	1
627412	3-21	1

PART NUMBER	FIGURE & INDEX	QTY PER ASSY
627433	2-18	5
	3-16	1
627673	18-12	1
627673-2	20-13	1
627681	28-41	2
627690	3-07	1
627819	33-27	1
627820	27-12	1
627836	28-37	1
627841	16-42	1
	17-30	1
628004	20-21	1
628036	36-06	12
628109	11-05	12
628136	7-14	4
	8-14	4
628152	30-	2
	31-	2
	32-	2
	33-	2
628153	30-	2
	31-	2
	32-	2
	33-	2
628154	30-68	2
	31-60	2
	32-61	2
	33-67	2
628257	3-02	1
628295	30-	1
	33-	1
628301	30-69	1
	33-68	1
628372A2	25-10	1
628372A4	25-	1
628436	30-08	1
628437	30-57	1
	31-05	1
	31-30	1
	31-48	1
	32-06	1
	32-27	1
	32-29	1
	32-50	1
	33-11	1
	33-32	1
	33-33	1
	33-56	1
628438	30-11	1
	30-13	1
	30-35	1
	32-08	1
	33-08	1
	33-12	1
628472	36-02	1
628473	36-02	1
628475	33-07	1
628476	30-10	1
	31-07	1
	32-07	1
	33-10	1
	33-34	1

PART NUMBER	FIGURE & INDEX	QTY PER ASSY
628478	30-34	1
	30-36	1
	31-06	1
	31-25	2
	32-28	1
628488	9-	12
	10-	12
628491	9-14	12
	10-15	12
628698A1	24-13	1
628700	28-17	1
628730	19-03	4
638739	36-07	1
628740	36-12	2
628750	7-15	6
	8-15	6
628760	16-36	1
628766	29-13	1
628816	29-27	1
628833	29-26	1
628859	14-	1
628861A1	29-18	1
629007	36-11	1
629008	36-10	1
	36-15	1
629009	36-09	1
	36-14	1
629010	36-08	1
	36-13	1
629011	36-16	1
629076	34-13	2
629077	34-15	2
629104	7-12	16
	8-12	16
629105	8-11	16
629117	13-19	6
629138	27-02	5
	28-02	5
	29-02	5
	28-10	1
629163	16-42	1
629176	17-30	1
	6-29	1
629201	6-28	1
629202	14-	1
629218	27-03	1
629325	28-03	1
	29-03	1
629329	30-24	1
629330	30-42	1
629338	30-49	1
629340	11-04	12
629351	30-31	1
629353	28-23	2
629354	28-24	1
629360	8-31	1
629364	30-40	1
629397A1	28-22	1
	30-	1
629399A1	30-	1
629401	12-05	6



PART NUMBER	FIGURE & INDEX	QTY PER ASSY
629411A1	27-18	1
	33-	1
629417	20-04	1
629422	34-13	2
629431A2	33-	1
629436	19-01	1
629448	14-19	1
629494	36-42	9
629495	36-28	6
629496	36-27	1
629498	36-26	6
629518-1	1-23	1
629518-1H	28-16	1
629518-3	1-24	2
629595	28-14	1
629601	28-15	1
629638	19-10	1
629668	17-25	1
629680	8-16	1
629703-2A2	30-30	1
629713	16-08	1
	17-09	1
629726	10-01	1
629747	10-08	1
629748	10-07	1
629806	22-14	1
629825	20-15	1
629837	35-27	2
	35-32	1
	36-39	2
629846	1-31	6
	4-31	6
629847	1-30	6
	4-30	6
629871	31-17	1
629904-2A2	31-21	1
630039	20-20	1
630046	12-06	6
630119	30-33	1
	31-27	1
	31-29	1
	33-31	1
	33-35	1
630124	31-11	1
630146-3	32-24	1
630184	30-65	1
	33-64	1
630261-27	7-08	2
	8-08	2
630261-3	7-09	2
	8-09	2
630261-4	7-10	4
	8-10	4
630327	31-41	3
	33-47	3
630350	28-52	1
	29-38	1
630387	30-48	3
	32-41	2
630464	7-13	10
630474	28-25	1
630533	35-06	12
	36-06	12
630590	19-	1
630591	13-11	6
630655	19-08	1
630680	17-11	1
630681	17-	1

PART NUMBER	FIGURE & INDEX	QTY PER ASSY
630691	19-11	1
	21-02	1
630693-10.44	5-07	1
630693-12.14	5-07	1
630694	6-20	1
630695	6-20	1
630752	12-02	6
	12-03	6
630763	31-01	1
	32-01	1
630849	23-01	2
630866	28-14	1
630868	28-13	1
630870	6-16	1
630871	6-14	1
630873	4-04	1
630892	6-02	1
630895	17-12	1
630899	4-03	1
630916	17-01	1
630947-1A1	30-	1
630947-1A3	33-	1
630947-2A1	31-	1
630947-2A2	32-	1
630966-.56	25-02	2
630966-4.0	5-35	3
630969	4-	1
631008	25-01	1
631014	15-	1
631016	15-	1
631034	15-01	1
631056	15-	1
631059	23-02	1
631075	15-	1
631088-.44	10-04	4
631096	4-	1
631121	19-	1
631220	28-19	1
631237	36-02	2
631246	31-61	1
	32-62	2
631252	16-12	1
	17-18	1
631263	31-02	1
	32-02	1
631266-1	3-42	1
631275-2	3-43	1
631287A1	28-22	1
	32-	1
631308	32-09	1
631330	30-63	1
	31-55	1
	32-56	1
	33-62	1
631351A10	30-	1
631351A6	33-	1
631367	24-07	1
631390	15-20	1
631393	6-21	1
631394	6-21	1
631406	28-17	1
631408A1	31-	1
631415A1	31-	1
631427A6	31-	1
631427A10	32-	1
631475	12-01	6
631478	14-54	1
631496	13-08	12

PART NUMBER	FIGURE & INDEX	QTY PER ASSY
631520	12-16	12
631521	13-15	12
631544	13-36	6
631547	19-04	1
631550A1	32-	1
631596	1-	1
631618	14-11	1
	15-09	1
631638	14-53	1
631641	15-	1
631645	15-49	1
631646	15-50	1
631650	14-35	1
	15-28	1
631653	14-13	1
	15-11	1
631658	23-12	1
	31-49	1
	32-49	1
631661	28-19	1
631674	13-01	6
631683	30-05	1
	33-05	1
631684	30-01	1
	33-01	1
631685	30-04	1
	33-04	1
631714	14-	1
631714A1	14-	1
631714A2	14-	1
631716A2	7-	1
631720	30-56	1
	33-55	1
631729	12-04	6
631737	36-41	2
631739	36-37	1
631745	28-19	1
631755	3-	1
631764	31-09	1
	32-11	1
	33-13	1
631783	15-52	1
631784	15-51	1
631790	28-17	1
631818	30-25	1
631819	30-19	1
631832	28-28	1
631836	28-47	2
631837	28-48	1
631840	28-49	1
631845	9-02	1
	10-03	1
631867	1-20	12
	4-23	36
631882	30-07	1
631915	3-40	1
631927	1-27	1
631928	3-39	1
631932	30-14	1
631968	7-	2
	8-	2
631972	27-07	8
	28-07	8
	29-07	8
631995	14-56	1
632015	28-34	1
632016	28-33	1
632017	31-04	1
	32-04	1

PART NUMBER	FIGURE & INDEX	QTY PER ASSY
632018	8-25	1
632020	6-37	1
632062-12	3-38	1
632062-15	3-38	1
632062-16	3-38	1
632062-2A1	3-	1
632062-4	3-38	1
632081	31-22	1
632085	14-37	1
632092-4	10-05	1
632105	35-26	2
	35-31	1
	36-38	1
632106	36-40	13
632112	18-20	1
632115	31-08	1
	32-10	1
632120	5-27	4
632125	19-13	1
632126	23-16	1
632149	3-43	1
632151	3-40	1
632224	23-11	1
632266	15-43	1
632276	23-11	1
632280	28-17	1
632357	3-06	1
632369	28-19	1
632379	15-53	1
632399	15-44	1
632436	19-06	1
	21-03	1
632437	19-05	1
	21-04	1
632443-4	5-41	6
	7-19	2
	8-19	2
632443-6	5-38	4
632444-2	28-18	1
632551	32-43	1
632556	32-19	1
632557	32-35	1
632558A1	32-33	1
632590	19-04	1
632663	25-14	4
632761	14-14	1
	15-12	1
632762	14-18	1
	15-16	1
632823	22-12	1
632824	22-13	1
632859	31-42	1
	33-48	1
632881	15-45	1
632892	8-21	1
632893	8-22	1
632916-2A1	32-23	1
632946	24-06	1
632958	36-02	1
632959	36-02	1
632964-1	6-03	1
632964-2	6-03	1
632970	15-	1
632977	15-	1
632977A1	15-	1
632992	36-	1
633005	36-	1

PART NUMBER	FIGURE & INDEX	QTY PER ASSY
633008-127	36-19	1
	36-20	1
	36-21	1
	36-22	1
	36-23	1
	36-24	1
	36-29	1
	36-30	1
	36-31	1
	36-32	1
	36-33	1
	36-34	1
633008-128	36-33	1
633009	36-25	1
633051	36-	1
633068	34-19	2
633121	32-05	1
633125	28-19	1
633129	28-17	1
633178	14-16	1
	15-14	1
633189	7-03	1
	8-03	1
633191	2-37	1
633233-3	6-07	1
633287	23-	1
633288	23-	1
633311	35-	1
633379	32-13	1
633403	11-	6
633412	24-13	1
633434	27-15	1
633435	27-13	1
	29-15	1
633442	14-19	1
633450	2-37	1
633579	35-08	1
	35-10	1
	35-11	1
	35-12	1
	35-14	1
	35-16	1
	35-18	1
633580	35-07	1
	35-09	1
	35-13	1
	35-15	1
	35-17	1
633581	35-24	1
633582	35-23	1
633583	35-22	1
633584	35-21	1
633585	35-20	1
633586	35-19	1
633620A2	8-	1
633821	29-12	1
633822	29-11	1
633823	29-19	1
633845	16-19	1
	17-15	1

PART NUMBER	FIGURE & INDEX	QTY PER ASSY
633977	2-37	1
634011	30-60	1
	31-52	1
	32-53	1
	33-59	1
	8-27	2
634021	23-10	1
634063	23-15	1
634065	8-26	4
634080	14-12	1
634150	15-10	1
	21-10	1
634571	16-42	1
634592	21-11	1
634617	23-12	1
634628	3-40	1
634630	21-09	1
634657	3-02	1
634673	1-	1
634685	21-01	1
634693	2-37	1
634936	6-37	1
634937	17-	1
635049	17-	1
635049A1	16-	1
635050		
635050A4	16-	1
635158-10.00	30-54	1
	33-53	1
635158-12.00	32-47	2
	33-52	1
635158-14.00	30-53	1
635158-32.00	30-55	1
	31-47	1
635158-38.00	31-46	2
635158-40.00	32-48	1
	33-54	1
635169	16-31	1
635439	8-13	10
635448	13-	6
635448A1	13-	6
635616	24-13	1
	26-07	1
635623	7-11	16
635640	24-02	1
	26-02	1
635645	28-19	1
635720	13-14	6
635960	2-37	1
635982	36-35	1
635987	36-36	1
636190	2-37	1
636196	2-37	1
636684	35-37	12
636688	35-36	10
636689	35-28	1
636690	35-29	1
636691	35-30	1
636692	35-25	2

## TABLE OF CONTENTS

IO-520-A Spec. 4 . . . . .	A1
IO-520-A Spec. 5 . . . . .	A3
IO-520-A Spec. 6 . . . . .	A5
IO-520-A Spec. 9 . . . . .	A7
IO-520-B Spec. 2 . . . . .	B1
IO-520-B Spec. 6A . . . . .	B3
IO-520-C Spec. 3A . . . . .	C1
IO-520-D Spec. 2 . . . . .	D1
IO-520-D Spec. 4 . . . . .	D3
IO-520-D Spec. 7 . . . . .	D7
IO-520-D Spec. 9A . . . . .	D9
IO-520-D Spec. 11 . . . . .	D11
IO-520-D Spec. 17 . . . . .	D15
IO-520-F Spec. 2 . . . . .	F1
IO-520-F Spec. 3A . . . . .	F7

# IO-520-A SPEC 4

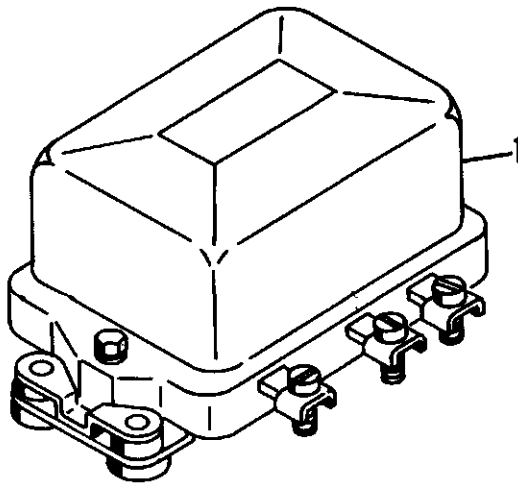

INDEX NO.	PART NUMBER	DESCRIPTION	UNITS PER ASSY.
- 1	627321	1 2 3 4 5 6 7 Regulator, Voltage, 12 Volt, 50 Amp. . . . .	1

# 10-520-A SPEC 5

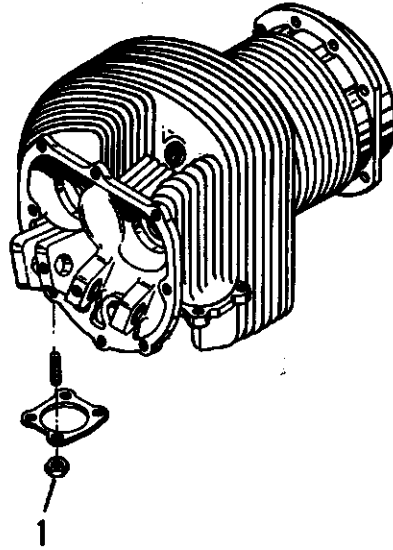

INDEX NO.	PART NUMBER	1	2	3	4	5	6	7	DESCRIPTION	UNITS PER ASSY.
- 1	536038								Nut, Special . . . . .	24

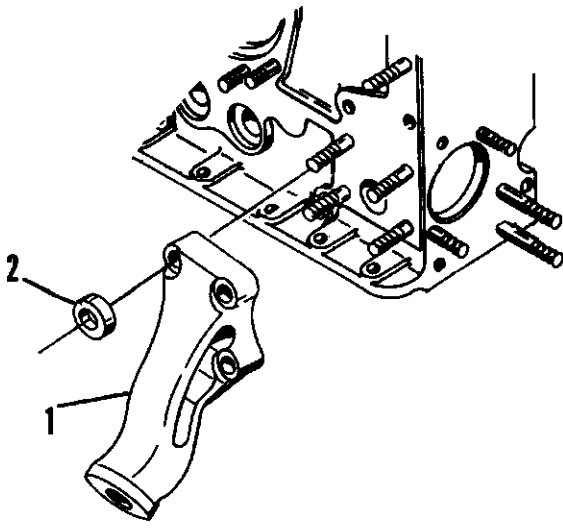

INDEX NO.	PART NUMBER	1	2	3	4	5	6	7	DESCRIPTION	UNITS PER ASSY.
- 1	628257								Bracket, Engine Mount . . . . .	1
- 2	632357								Spacer . . . . .	1

# IO-520-A SPEC 5

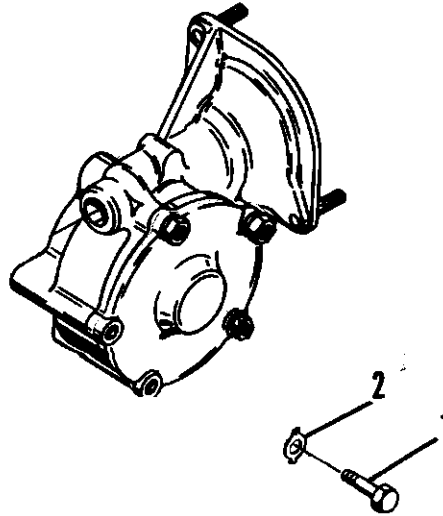

INDEX NO.	PART NUMBER	DESCRIPTION							UNITS PER ASSY.
		1	2	3	4	5	6	7	
- 1	537750	Bolt . . . . .							1
- 2	501868	Washer, Tab. . . . .							1

# IO-520-A SPEC 6

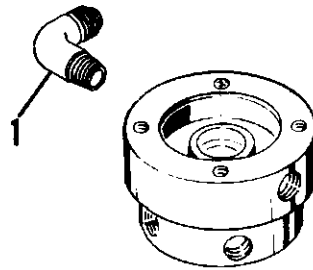

INDEX NO.	PART NUMBER	1	2	3	4	5	6	7	DESCRIPTION	UNITS PER ASS'Y.
- 1	631658								Elbow, 90 Degrees, Fuel Pressure-at-Manifold Valve . . . . .	1

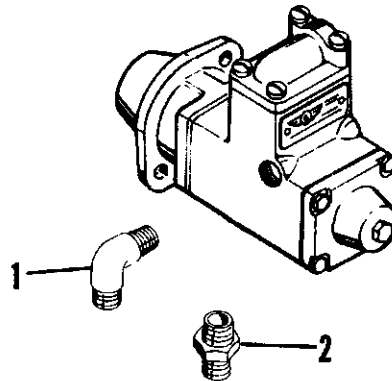

INDEX NO.	PART NUMBER	1	2	3	4	5	6	7	DESCRIPTION	UNITS PER ASS'Y.
- 1	628475								Elbow, 90 Degrees, Fuel Pump Inlet . . . . .	1
- 2	628434								Connector, Fuel Pump Adapter Drain . . . . .	1



# 10-520-A SPEC 6

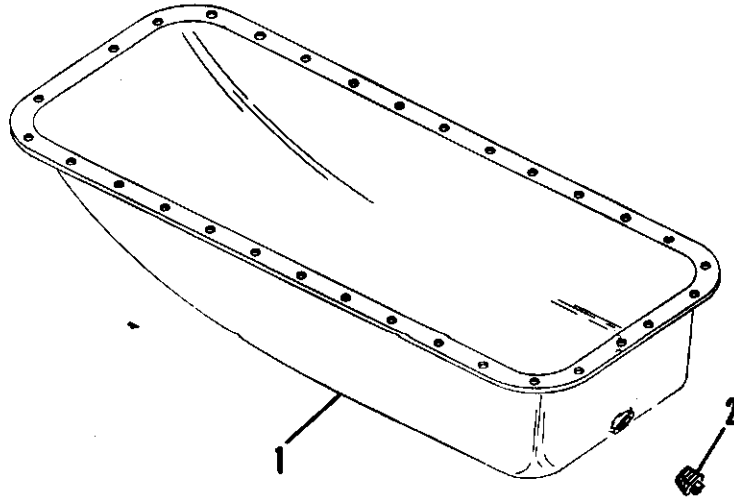

INDEX NO.	PART NUMBER	DESCRIPTION							UNITS PER ASS'Y.
		1	2	3	4	5	6	7	
	538517A1	Sump Assembly, Oil, Complete . . . . .							1
- 1	No Number	. Sump Assembly, Oil . . . . .							1
- 2	629518-4H	. Plug, Oil Drain . . . . .							1

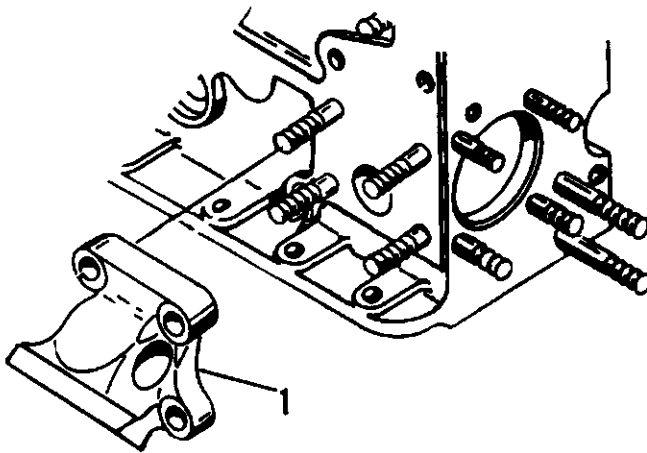

INDEX NO.	PART NUMBER	DESCRIPTION							UNITS PER ASS'Y.
		1	2	3	4	5	6	7	
- 1	539914	Bracket, Engine Mount . . . . .							4

# IO-520-A SPEC 9

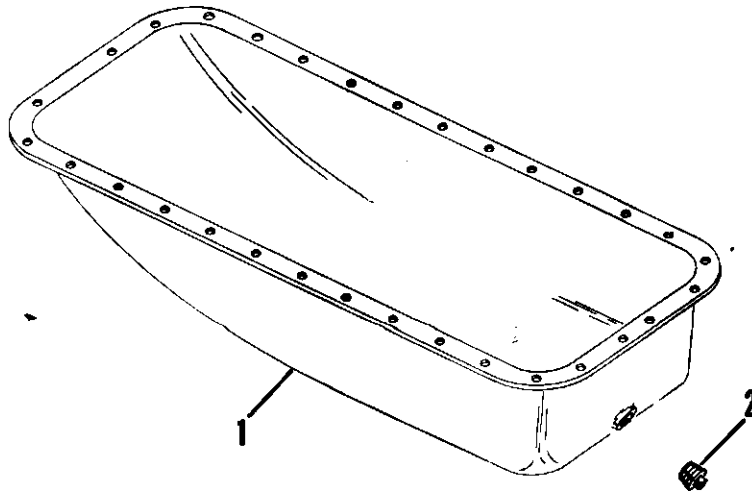

INDEX NO.	PART NUMBER	DESCRIPTION							UNITS PER ASS'Y.	
		1	2	3	4	5	6	7		
	538517A1	Sump Assembly, Oil, Complete	.	.	.	.	.	.	.	1
- 1	No Number	. Sump Assembly, Oil	.	.	.	.	.	.	.	1
- 2	629518-4H	. Plug, Oil Drain	.	.	.	.	.	.	.	1

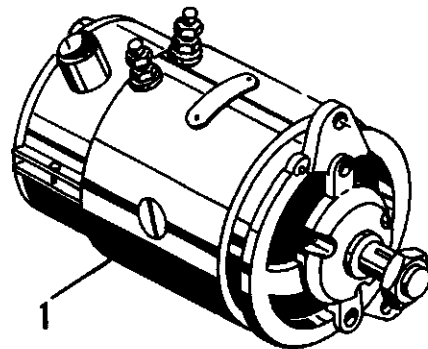
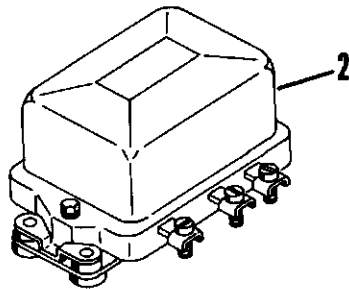

INDEX NO.	PART NUMBER	DESCRIPTION							UNITS PER ASS'Y.	
		1	2	3	4	5	6	7		
- 1	627273	Generator, 12 Volt, 35 Amp.	.	.	.	.	.	.	.	1
- 2	627322	Regulator, Voltage & Current	.	.	.	.	.	.	.	1

# 10-520-A SPEC 9

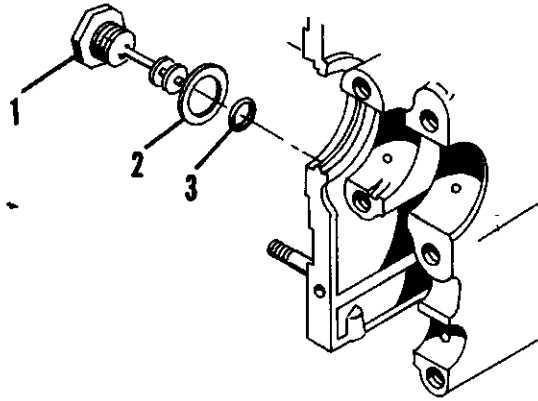

INDEX NO.	PART NUMBER	DESCRIPTION							UNITS PER ASS'Y.
		1	2	3	4	5	6	7	
- 1	626334								1
- 2	625966								1
- 3	AN123866								1

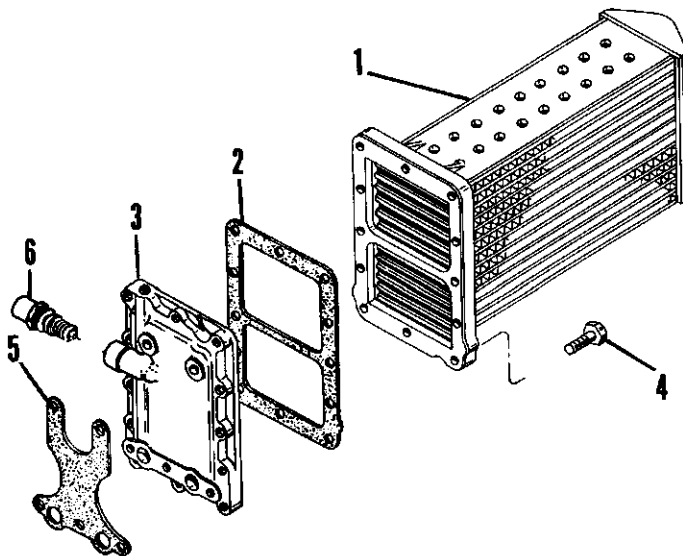

INDEX NO.	PART NUMBER	DESCRIPTION							UNITS PER ASS'Y.
		1	2	3	4	5	6	7	
- 1	630050								1
- 2	626342								1
- 3	626332								1
- 4	535668								12
- 5	632341								1
- 6	627702								1

# 10-520-A SPEC 9

INDEX NO.	PART NUMBER	DESCRIPTION							UNITS PER ASS'Y.
		1	2	3	4	5	6	7	
- 1	631237	Magneto Assembly, Model S6RN-25							
		Bendix Scintilla No. 10-79020-10. . . . .							2
- 2	352024	Kit, Ground Terminal, L. H. & R. H. Magneto							2
- 3	25318	. Nut, 5/8-24 . . . . .							1
- 4	25317	. Ferrule, Shielded Ground Wire, Outer . . . . .							1
- 5	25316	. Ferrule, Shielded Ground Wire, Inner . . . . .							1
- 6	530455	. Sleeve, Insulating . . . . .							1
- 7	25314	. Washer, Special . . . . .							1
- 8	25321	Washer, Lock . . . . .							8
- 9	25320	Screw, 10-32 X 5/8 In. Lg. . . . .							8
-10	25312	Plate, 6 Cylinder Shielded Cable Outlet . . . . .							2
-11	36219	Grommet, Plate . . . . .							2
-12	627001	Sleeve, Magneto Distributor Block . . . . .							12
-13	627002	Washer, Magneto Block . . . . .							12
	627805	Harness Assembly, Left Magneto. . . . .							1
-14	627040-36.94	. Cable Assembly, No. 1 Cylinder, Lower . . . . .							1
-15	627040-19.44	. Cable Assembly, No. 2 Cylinder, Upper . . . . .							1
-16	627040-37.19	. Cable Assembly, No. 3 Cylinder, Lower . . . . .							1
-17	627040-18.94	. Cable Assembly, No. 4 Cylinder, Upper . . . . .							1
-18	627040-42.19	. Cable Assembly, No. 5 Cylinder, Lower . . . . .							1
-19	627040-23.19	. Cable Assembly, No. 6 Cylinder, Upper . . . . .							1
	627804	Harness Assembly, Right Magneto . . . . .							1
-20	627040-16.19	. Cable Assembly, No. 1 Cylinder, Upper . . . . .							1
-21	627040-39.19	. Cable Assembly, No. 2 Cylinder, Lower . . . . .							1
-22	627040-19.44	. Cable Assembly, No. 3 Cylinder, Upper . . . . .							1
-23	627040-35.69	. Cable Assembly, No. 4 Cylinder, Lower . . . . .							1
-24	627040-22.69	. Cable Assembly, No. 5 Cylinder, Upper . . . . .							1
-25	627040-41.69	. Cable Assembly, No. 6 Cylinder, Lower . . . . .							1
	539140	Bracket Assembly, Ignition Harness (6 Wire) . . . . .							1
-26	630093	. Bracket and Nut Assembly . . . . .							1
-27	535557	. Clip, Ignition Harness Bracket . . . . .							1
-28	AN936A8	. Washer, Lock . . . . .							2
-29	AN515-8-6	. Screw, No. 8-32 X 3/8 In. Lg. . . . .							2
-30	627921	Clamp, Ignition Harness . . . . .							2
-31	627759	Bolt, No. 6-32 X 5/16 In. Lg. . . . .							2
-32	627756	Nut, No. 6-32 . . . . .							2
-33	626577-2R	Clamp, Ignition Cable. . . . .							12

# IO-520-A SPEC 9

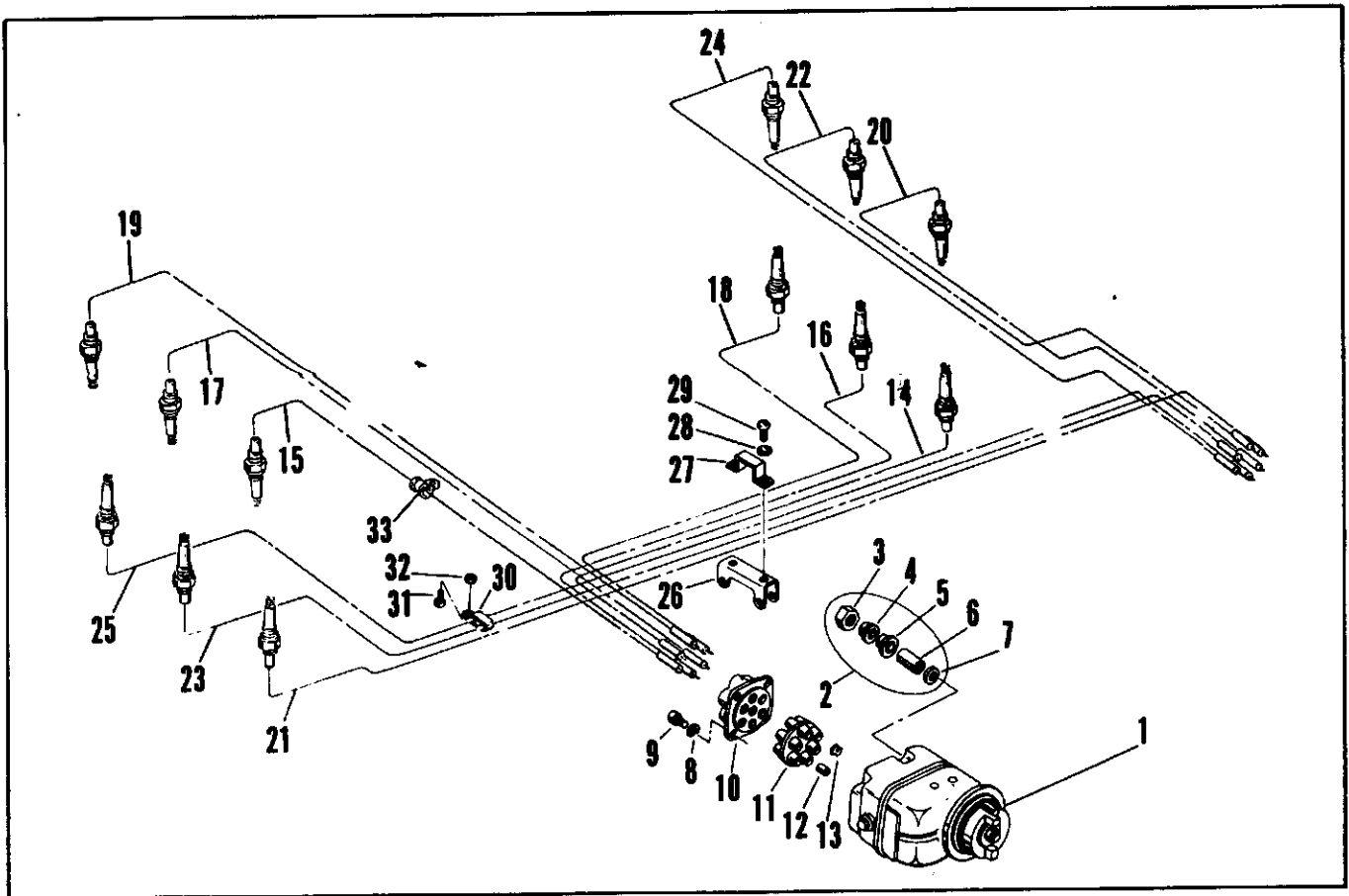

# 10-520-B SPEC 2

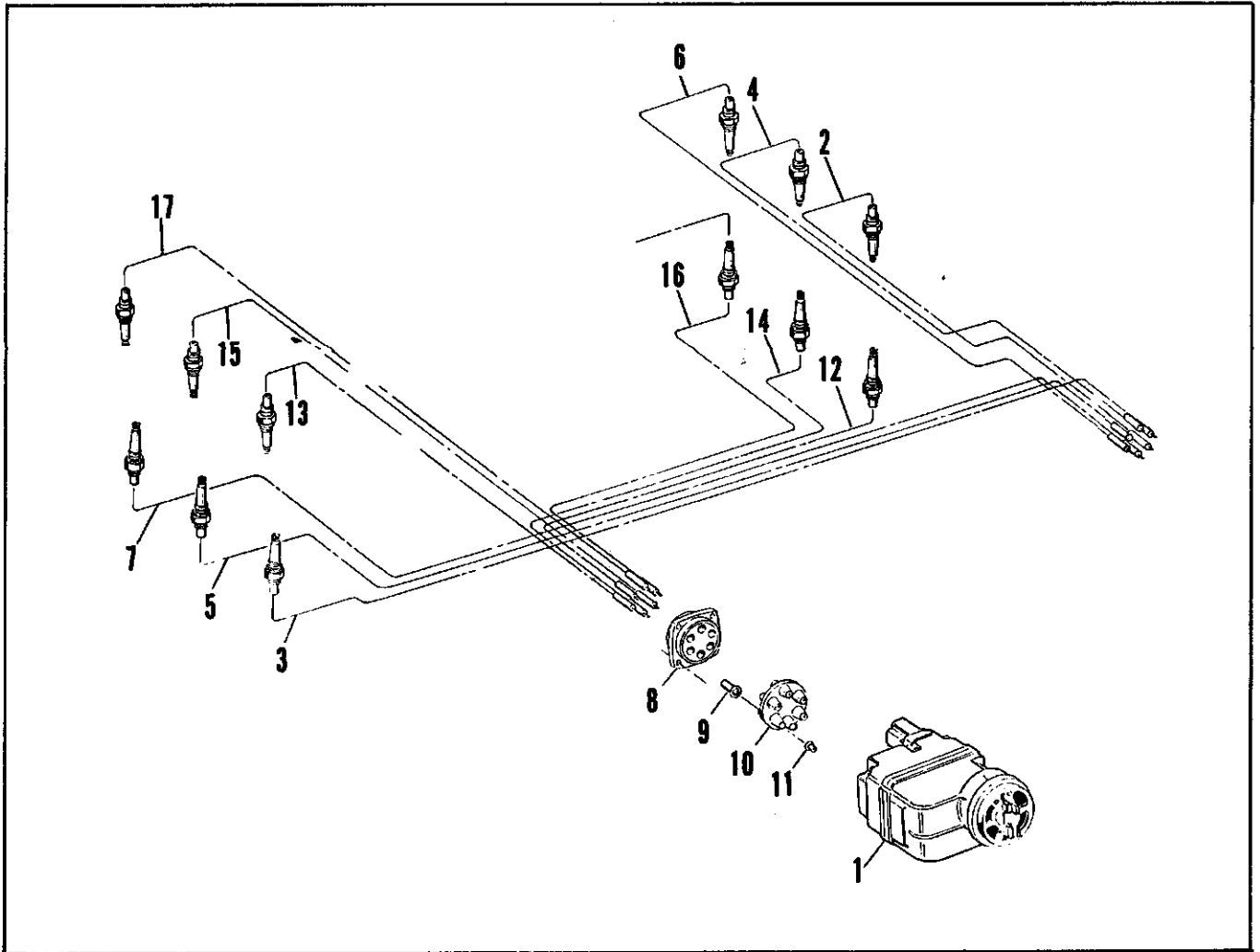

INDEX NO.	PART NUMBER	DESCRIPTION						UNITS PER ASS'Y.
		1	2	3	4	5	6	
- 1	632958	Magneto Assembly, L. H., Model S6RN-1201 Bendix Scintilla No. 10-349220-1. . . . .						1
- 1	632959	Magneto Assembly, R. H., Model S6RN-1205 Bendix Scintilla No. 10-349260-1. . . . .						1
	633051	Harness Assembly, Complete . . . . .						1
	No Number	. . . Harness Assembly, Right Magneto . . . . .						NS
- 2	633008-127 **	. . . Cable Assembly, No. 1 Upper, 16.28 In. Lg. . . . .						1
- 3	633008-127 **	. . . Cable Assembly, No. 2 Lower, 39.45 In. Lg. . . . .						1
- 4	633008-127 **	. . . Cable Assembly, No. 3 Upper, 20.84 In. Lg. . . . .						1
- 5	633008-127 **	. . . Cable Assembly, No. 4 Upper, 37.07 In. Lg. . . . .						1
- 6	633008-127 **	. . . Cable Assembly, No. 5 Lower, 29.44 In. Lg. . . . .						1
- 7	633008-127 **	. . . Cable Assembly, No. 6 Lower, 43.17 In. Lg. . . . .						1
- 8	633009 *	. . . Plate, Cable Outlet . . . . .						1
- 9	629498 *#	. . . Ferrule, Cable. . . . .						6
-10	629496 *	. . . Grommet, Plate . . . . .						1
-11	629495 *	. . . Eyelet, Cable Contact. . . . .						6
	No Number	. . . Harness Assembly, Left Magneto. . . . .						NS
-12	633008-127 **	. . . Cable Assembly, No. 1 Lower, 37.55 In. Lg. . . . .						1
-13	633008-127 **	. . . Cable Assembly, No. 2 Upper, 21.61 In. Lg. . . . .						1
-14	633008-127 **	. . . Cable Assembly, No. 3 Lower, 41.94 In. Lg. . . . .						1
-15	633008-127 **	. . . Cable Assembly, No. 4 Upper, 17.98 In. Lg. . . . .						1
-16	633008-127 **	. . . Cable Assembly, No. 5 Lower, 48.67 In. Lg. . . . .						1
-17	633008-127 **	. . . Cable Assembly, No. 6 Upper, 25.53 In. Lg. . . . .						1

# IO-520-B SPEC 6A

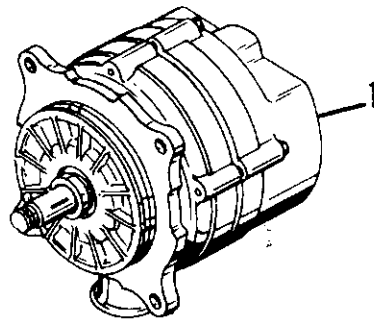

INDEX NO.	PART NUMBER	1	2	3	4	5	6	7	DESCRIPTION	UNITS PER ASS'Y.
- 1	634785								Alternator . . . . .	1

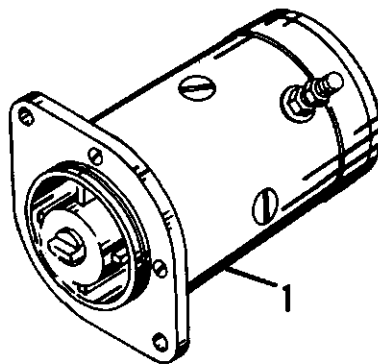

INDEX NO.	PART NUMBER	1	2	3	4	5	6	7	DESCRIPTION	UNITS PER ASS'Y.
- 1	634592								Starter, 12 Volt . . . . .	1

# IO-520-C SPEC 3A

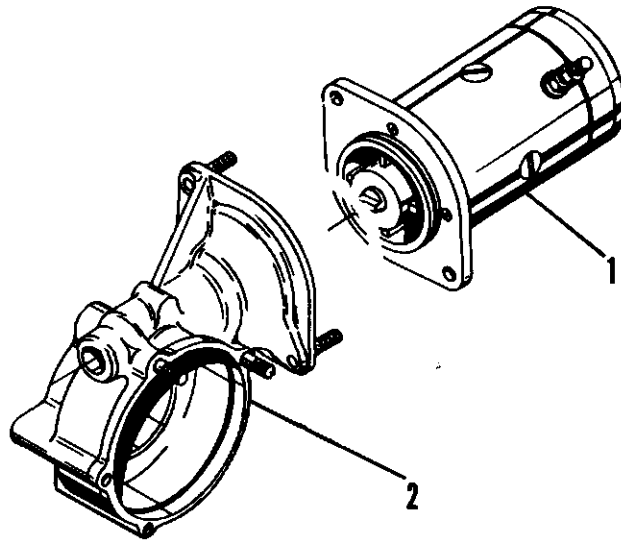

FIGURE & INDEX NO.	PART NUMBER	DESCRIPTION							UNITS PER ASS'Y.	
		1	2	3	4	5	6	7		
- 1	634433	Starter	.	.	.	.	.	.	.	1
- 2	635049A1	Adapter Assembly, Starter	.	.	.	.	.	.	.	1

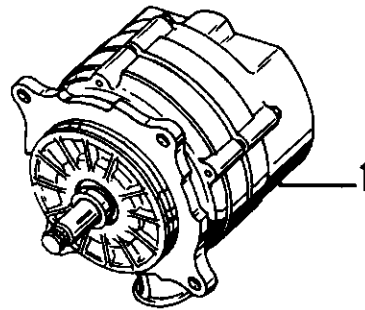
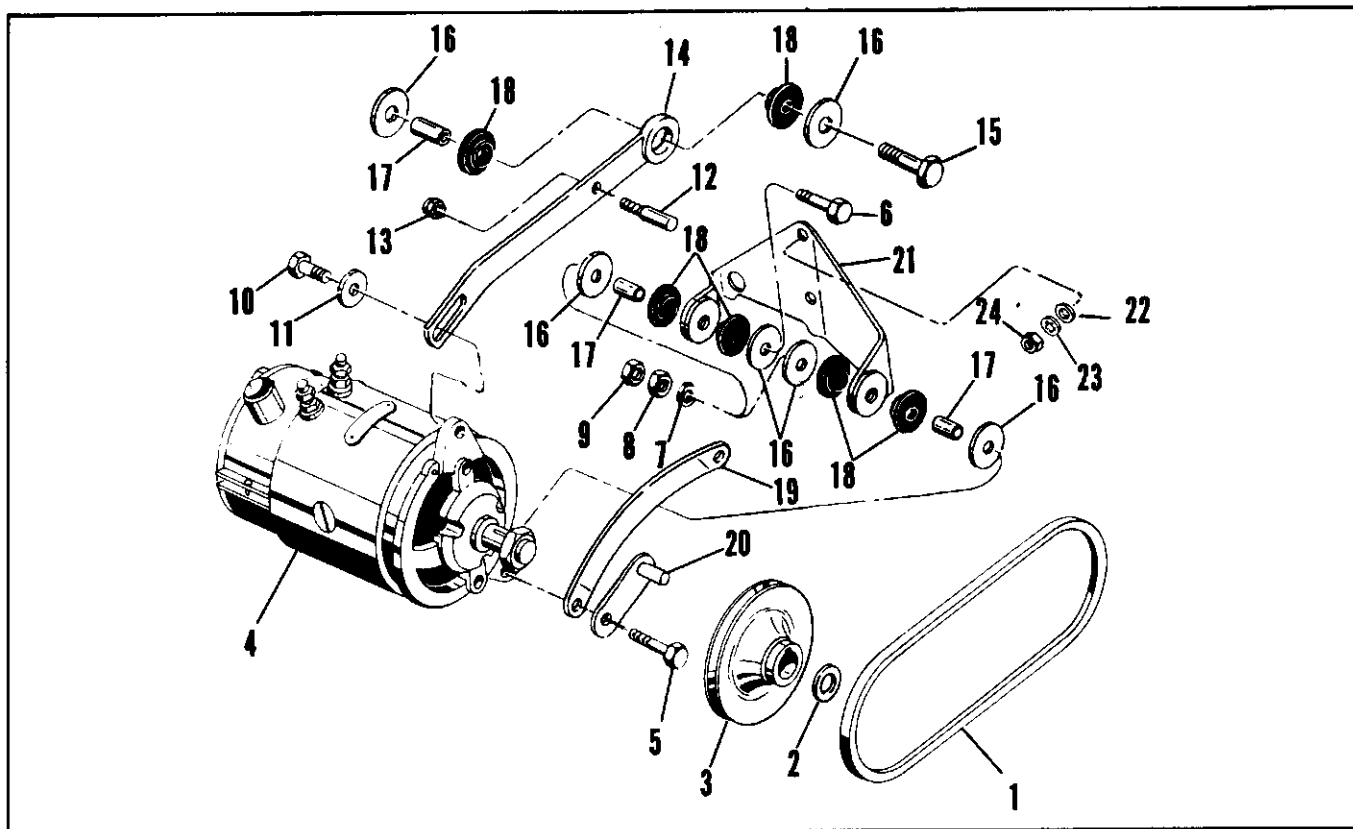

FIGURE & INDEX NO.	PART NUMBER	DESCRIPTION							UNITS PER ASS'Y.	
		1	2	3	4	5	6	7		
- 1	634445	Alternator	.	.	.	.	.	.	.	1



# IO-520-D SPEC 2



INDEX NO.	PART NUMBER	DESCRIPTION							UNITS PER ASS'Y.
		1	2	3	4	5	6	7	
- 1	539547-31.19	Belt, Generator Driven . . . . .							1
- 2	536213	Spacer, Generator Driven . . . . .							1
- 3	627377	Sheave, Generator Driven . . . . .							1
- 4	627272	Generator, 12 Volt, 50 Amp . . . . .							1
ATTACHING PARTS									
- 5	AN5-20A	Bolt . . . . .							1
- 6	AN5-15A	Bolt . . . . .							1
- 7	2473	Washer, Plain . . . . .							1
- 8	AN315-5R	Nut, Plain, Hex . . . . .							2
- 9	2560	Palnut . . . . .							2
-10	AN75A6	Bolt . . . . .							1
-11	537539	Washer, Plain . . . . .							1
* - - - - *									
-12	627673	Idler, Kiss . . . . .							1
ATTACHING PARTS									
-13	22661	Nut, Self Locking, 1/4-28 . . . . .							1
* - - - - *									
-14	627276	Bracket, Generator Adjusting Arm . . . . .							1
-15	AN75A15	Screw . . . . .							1
-16	627279	Washer, Special . . . . .							6
-17	627281	Bushing, Spacer . . . . .							3
-18	627282	Bushing, Rubber . . . . .							6
-19	627068	Bracket, Generator Support . . . . .							1
-20	632112	Bracket Assembly, Kiss Idler . . . . .							1
-21	627690	Bracket, Generator Mounting . . . . .							1
-22	2794	Washer . . . . .							1
-23	AN936A516	Washer, Lock . . . . .							1
-24	AN315-5R	Nut, Plain, Hex . . . . .							1

# IO-520-D SPEC 2

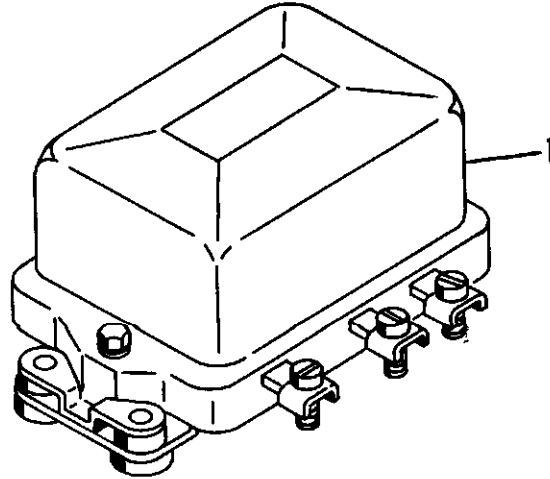

INDEX NO.	PART NUMBER	DESCRIPTION	UNITS PER ASS'Y.
- 1	627321	1 2 3 4 5 6 7 Regulator, Voltage, 12 Volt, 50 Amp. . . . .	1

# IO-520-D SPEC 4

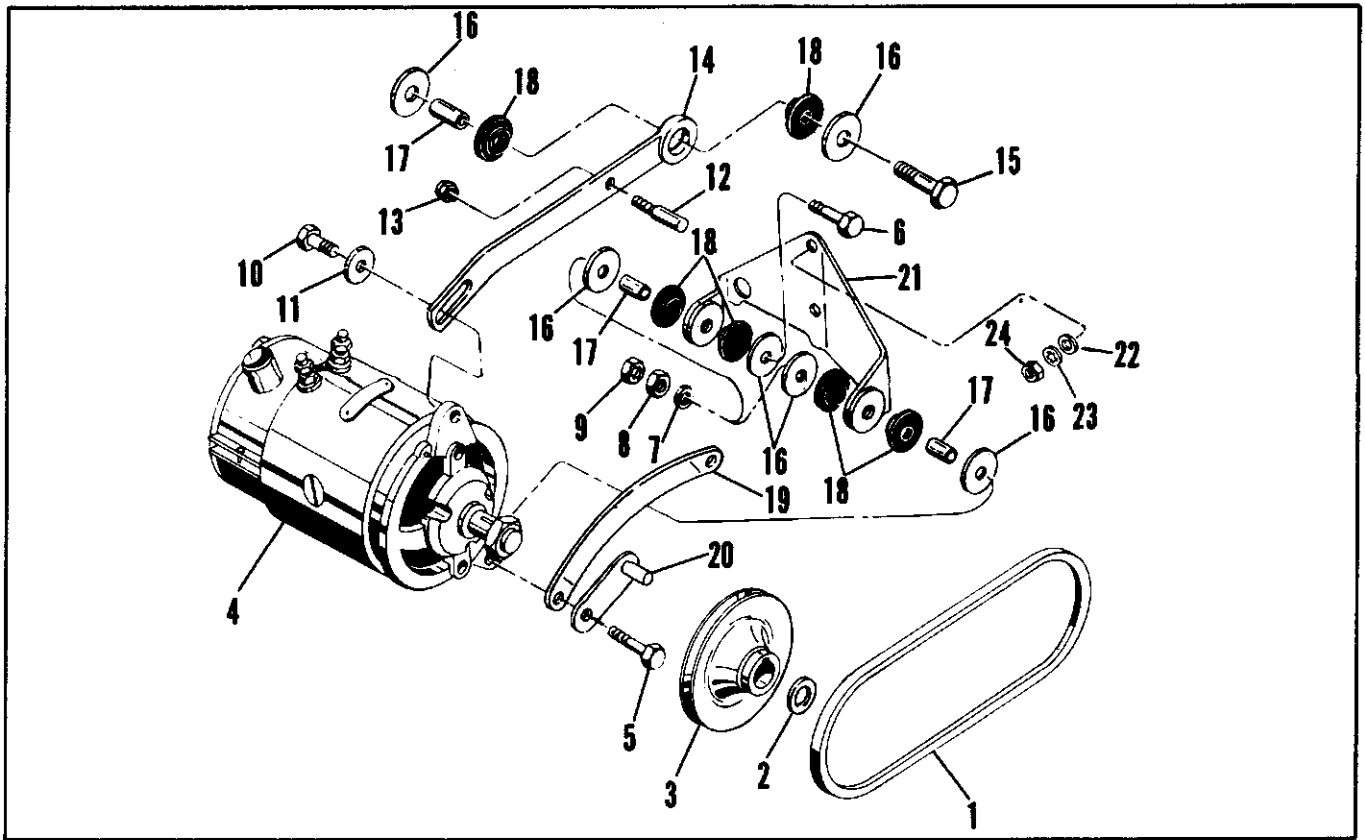

INDEX NO.	PART NUMBER	DESCRIPTION							UNITS PER ASS'Y.	
		1	2	3	4	5	6	7		
- 1	539547-31, 19	Belt, Generator Driven . . . . .								1
- 2	536213	Spacer, Generator Driven . . . . .								1
- 3	627377	Sheave, Generator Driven . . . . .								1
- 4	627272	Generator, 12 Volt, 50 Amp. . . . .								1
ATTACHING PARTS										
- 5	AN5-20A	Bolt. . . . .								1
- 6	AN5-15A	Bolt. . . . .								1
- 7	2473	Washer, Plain . . . . .								1
- 8	AN315-5R	Nut, Plain, Hex . . . . .								2
- 9	2560	Palnut. . . . .								2
-10	AN75A6	Bolt. . . . .								1
-11	537539	Washer, Plain . . . . .								1
* * * * *										
-12	627673	Idler, Kiss . . . . .								1
ATTACHING PARTS										
-13	22661	Nut, Self Locking, 1/4-28 . . . . .								1
* * * * *										
-14	627276	Bracket, Generator Adjusting Arm . . . . .								1
-15	AN75A15	Screw . . . . .								1
-16	627279	Washer, Special . . . . .								6
-17	627281	Bushing, Spacer . . . . .								3
-18	627282	Bushing, Rubber . . . . .								6
-19	627068	Bracket, Generator Support . . . . .								1
-20	632112	Bracket Assembly, Kiss Idler . . . . .								1
-21	627690	Bracket, Generator Mounting . . . . .								1
-22	2794	Washer . . . . .								1
-23	AN936A516	Washer, Lock . . . . .								1
-24	AN315-5R	Nut, Plain, Hex . . . . .								1

# IO-520-D SPEC 4

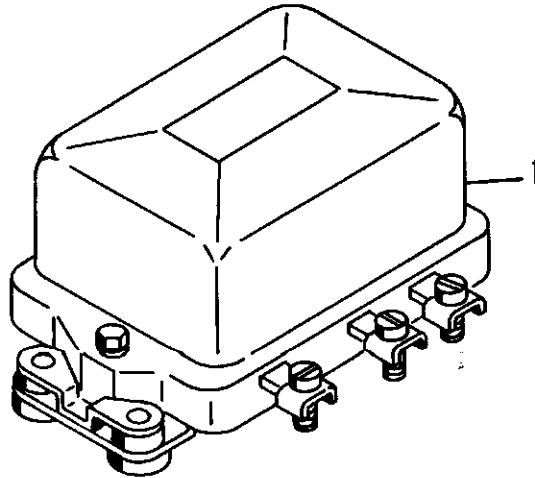

INDEX NO.	PART NUMBER	1	2	3	4	5	6	7	DESCRIPTION	UNITS PER ASS'Y.
- 1	627321								Regulator, Voltage, 12 Volt, 50 Amp. . . . .	1

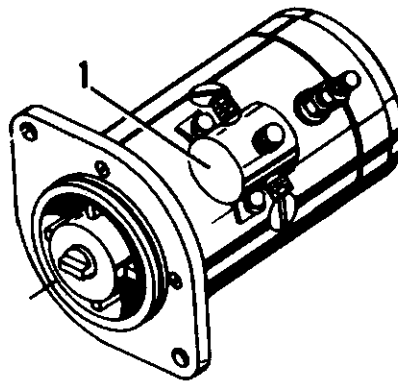

INDEX NO.	PART NUMBER	1	2	3	4	5	6	7	DESCRIPTION	UNITS PER ASS'Y.
- 1	634179								Magnetic Switch, 12 Volt . . . . .	1

# IO-520-D SPEC 4

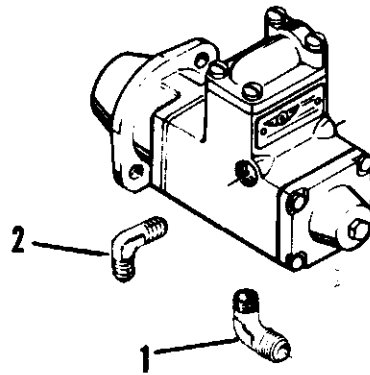

INDEX NO.	PART NUMBER	DESCRIPTION							UNITS PER ASSY.	
		1	2	3	4	5	6	7		
- 1	628437								Elbow, 90 Degrees, Fuel Pump-to-Metering Unit . . . . .	1
- 2	631882								Elbow, 90 Degrees, Fuel Pump Inlet . . . . .	1

# IO-520-D SPEC 7

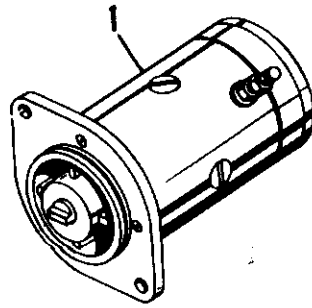

INDEX NO.	PART NUMBER	DESCRIPTION	UNITS PER ASS'Y.
- 1	627841	<div style="display: flex; justify-content: space-around; font-size: small;"> <span>1</span><span>2</span><span>3</span><span>4</span><span>5</span><span>6</span><span>7</span> </div> Starter, 24 Volt . . . . .	1

# IO-520-D SPEC 9A

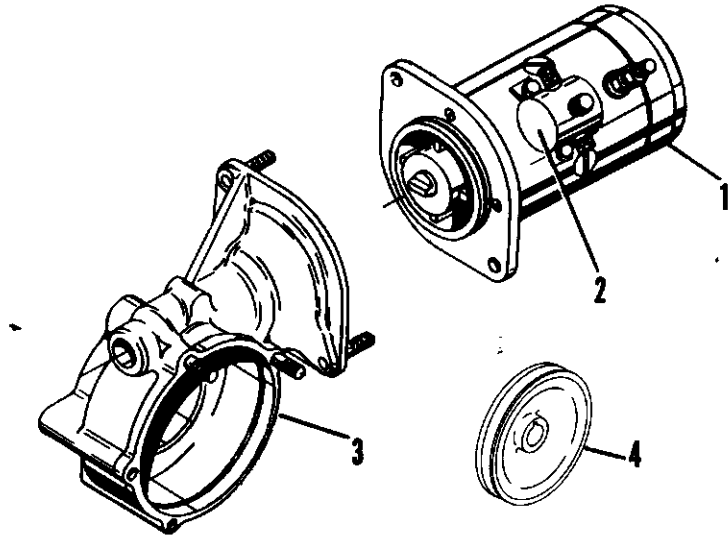
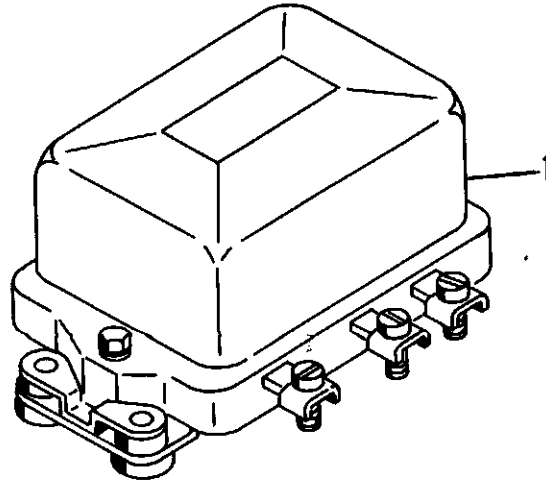
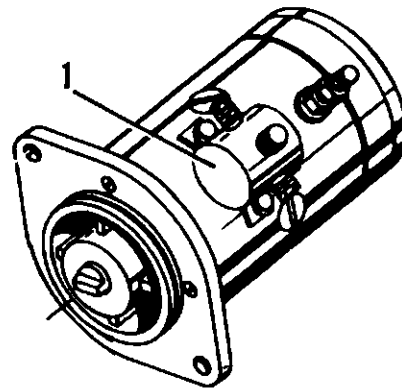

FIGURE & INDEX NO.	PART NUMBER								DESCRIPTION	UNITS PER ASS'Y.
		1	2	3	4	5	6	7		
- 1	634592								Starter . . . . .	1
- 2	634660								Magnetic Switch . . . . .	1
- 3	635050A4								Adapter Assembly, Starter . . . . .	1
- 4	635169								Sheave. . . . .	1

# IO-520-D SPEC 11



INDEX NO.	PART NUMBER	1	2	3	4	5	6	7	DESCRIPTION	UNITS PER ASS'Y.
- 1	627321								Regulator, Voltage, 12 Volt, 50 Amp. . . . .	1



INDEX NO.	PART NUMBER	1	2	3	4	5	6	7	DESCRIPTION	UNITS PER ASS'Y.
- 1	634179								Magnetic Switch, 12 Volt . . . . .	1



# IO-520-D SPEC 11

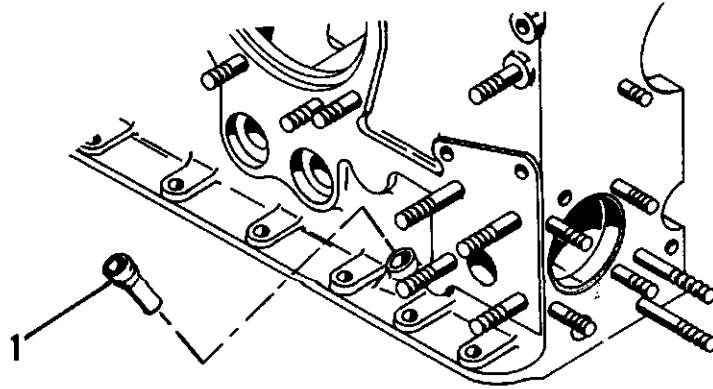
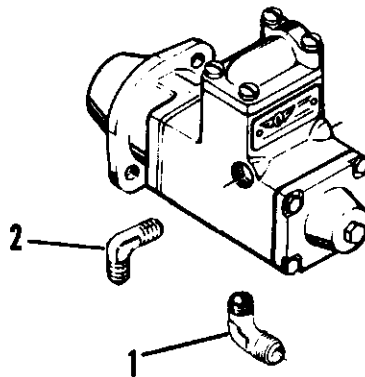

FIGURE & INDEX NO.	PART NUMBER	1	2	3	4	5	6	7	DESCRIPTION	UNITS PER ASS'Y.
- 1	631927								Housing, Oil Gage Rod . . . . .	1



INDEX NO.	PART NUMBER	1	2	3	4	5	6	7	DESCRIPTION	UNITS PER ASS'Y.
- 1	628437								Elbow, 90 Degrees, Fuel Pump-to-Metering Unit . . . . .	1
- 2	631882								Elbow, 90 Degrees, Fuel Pump Inlet . . . . .	1

# IO-520-D SPEC 11

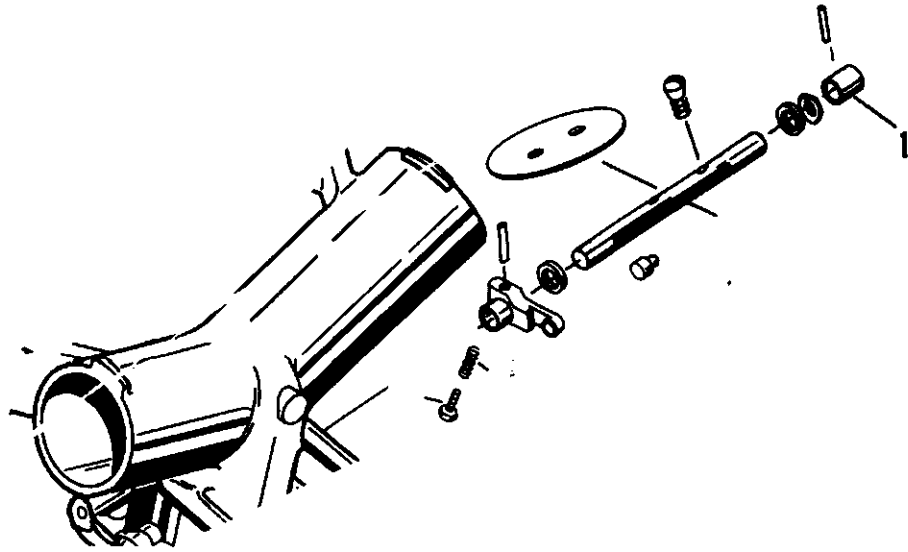

FIGURE & INDEX NO.	PART NUMBER	DESCRIPTION							UNITS PER ASS'Y.	
		1	2	3	4	5	6	7		
- 1	625238	Collar, Air Throttle . . . . .								1
	628308A2	Throttle Body & Control Assembly . . . . .								1
	627888A1	. Throttle & Lever Assembly . . . . .								1

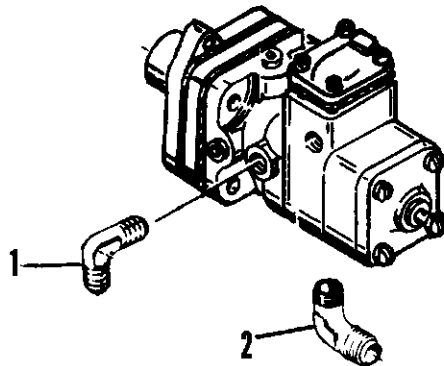
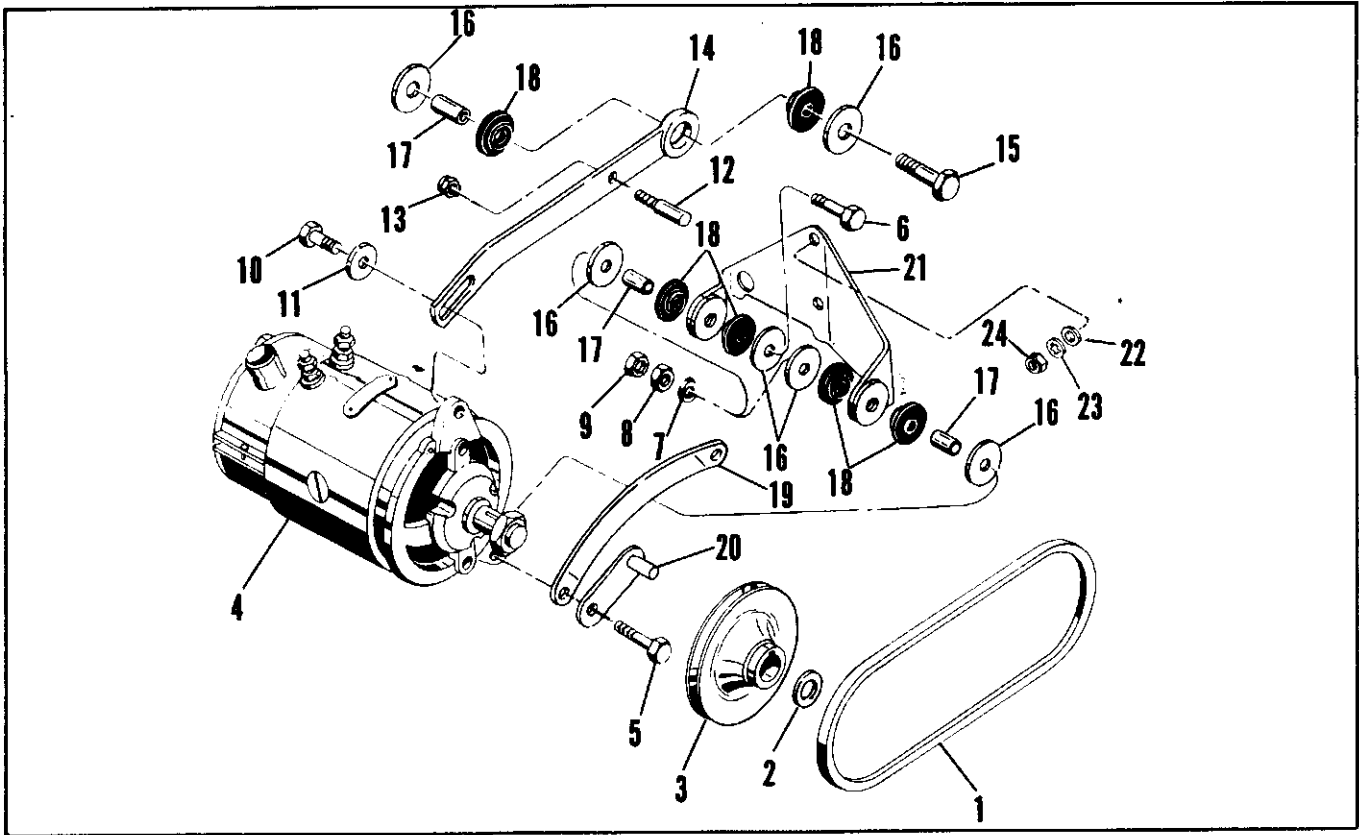

FIGURE & INDEX NO.	PART NUMBER	DESCRIPTION							UNITS PER ASS'Y.	
		1	2	3	4	5	6	7		
	630947-1A4	Fuel Pump Assembly, Complete . . . . .								1
- 1	631882	Elbow, 90 Degree, Fuel Pump Inlet . . . . .								1
- 2	628437	Elbow, 90 Degree, Fuel Outlet . . . . .								1

# IO-520-D SPEC 11



INDEX NO.	PART NUMBER	DESCRIPTION							UNITS PER ASS'Y.
		1	2	3	4	5	6	7	
- 1	539547-31.19	.	.	.	.	.	.	.	1
- 2	536213	.	.	.	.	.	.	.	1
- 3	627377	.	.	.	.	.	.	.	1
- 4	627272	.	.	.	.	.	.	.	1
ATTACHING PARTS									
- 5	AN5-20A	.	.	.	.	.	.	.	1
- 6	AN5-15A	.	.	.	.	.	.	.	1
- 7	2473	.	.	.	.	.	.	.	1
- 8	AN315-5R	.	.	.	.	.	.	.	2
- 9	2560	.	.	.	.	.	.	.	2
-10	AN75A6	.	.	.	.	.	.	.	1
-11	537539	.	.	.	.	.	.	.	1
* - - - *									
-12	627673	.	.	.	.	.	.	.	1
ATTACHING PARTS									
-13	22661	.	.	.	.	.	.	.	1
* - - - *									
-14	627276	.	.	.	.	.	.	.	1
-15	AN75A15	.	.	.	.	.	.	.	1
-16	627279	.	.	.	.	.	.	.	6
-17	627281	.	.	.	.	.	.	.	3
-18	627282	.	.	.	.	.	.	.	6
-19	627068	.	.	.	.	.	.	.	1
-20	632112	.	.	.	.	.	.	.	1
-21	627690	.	.	.	.	.	.	.	1
-22	2794	.	.	.	.	.	.	.	1
-23	AN936A516	.	.	.	.	.	.	.	1
-24	AN315-5R	.	.	.	.	.	.	.	1

# 10-520-D SPEC 17

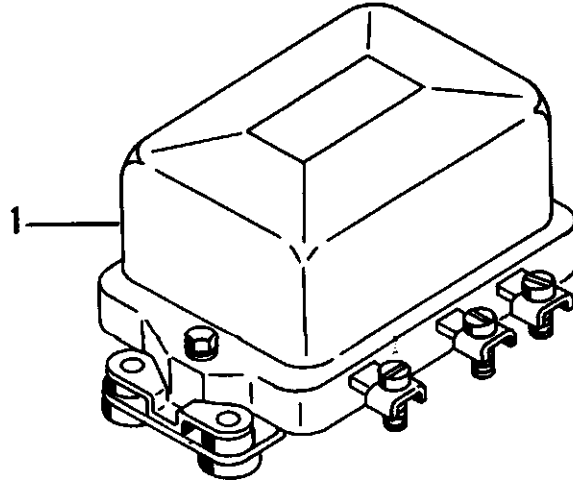

INDEX NO.	PART NUMBER	1	2	3	4	5	6	7	DESCRIPTION	UNITS PER ASS'Y.
- 1	627321								Regulator, Voltage, 12 Volt, 50 Amp. . . . .	1

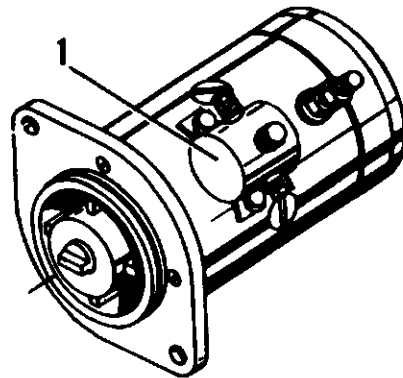

INDEX NO.	PART NUMBER	1	2	3	4	5	6	7	DESCRIPTION	UNITS PER ASS'Y.
- 1	634179								Magnetic Switch, 12 Volt . . . . .	1

# 10-520-D SPEC 17

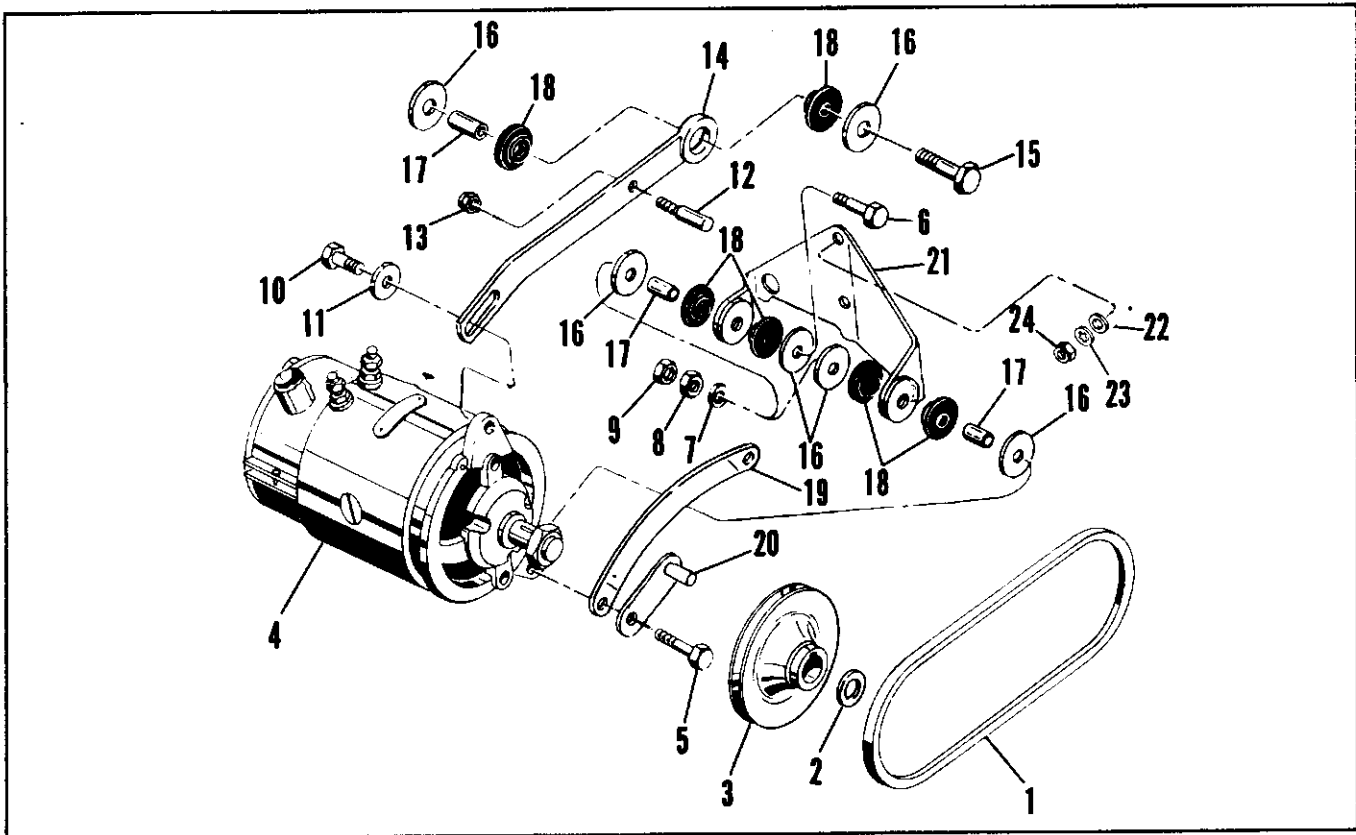

INDEX NO.	PART NUMBER	DESCRIPTION							UNITS PER ASS'Y.	
		1	2	3	4	5	6	7		
- 1	539547-31.19	Belt, Generator Driven . . . . .								1
- 2	536213	Spacer, Generator Driven . . . . .								1
- 3	627377	Sheave, Generator Driven . . . . .								1
- 4	627272	Generator, 12 Volt, 50 Amp. . . . .								1
ATTACHING PARTS										
- 5	AN5-20A	Bolt . . . . .								1
- 6	AN5-15A	Bolt . . . . .								1
- 7	2473	Washer, Plain . . . . .								1
- 8	AN315-5R	Nut, Plain, Hex . . . . .								2
- 9	2560	Palnut . . . . .								2
-10	AN75A6	Bolt . . . . .								1
-11	537539	Washer, Plain . . . . .								1
* - - - -										
-12	627673	Idler, Kiss . . . . .								1
ATTACHING PARTS										
-13	22661	Nut, Self Locking, 1/4-28 . . . . .								1
* - - - -										
-14	627276	Bracket, Generator Adjusting Arm . . . . .								1
-15	AN75A15	Screw . . . . .								1
-16	627279	Washer, Special . . . . .								6
-17	627281	Bushing, Spacer . . . . .								3
-18	627282	Bushing, Rubber . . . . .								6
-19	627068	Bracket, Generator Support . . . . .								1
-20	632112	Bracket Assembly, Kiss Idler . . . . .								1
-21	627690	Bracket, Generator Mounting . . . . .								1
-22	2794	Washer . . . . .								1
-23	AN936A516	Washer, Lock . . . . .								1
-24	AN315-5R	Nut, Plain, Hex . . . . .								1

# 10-520-D SPEC 17

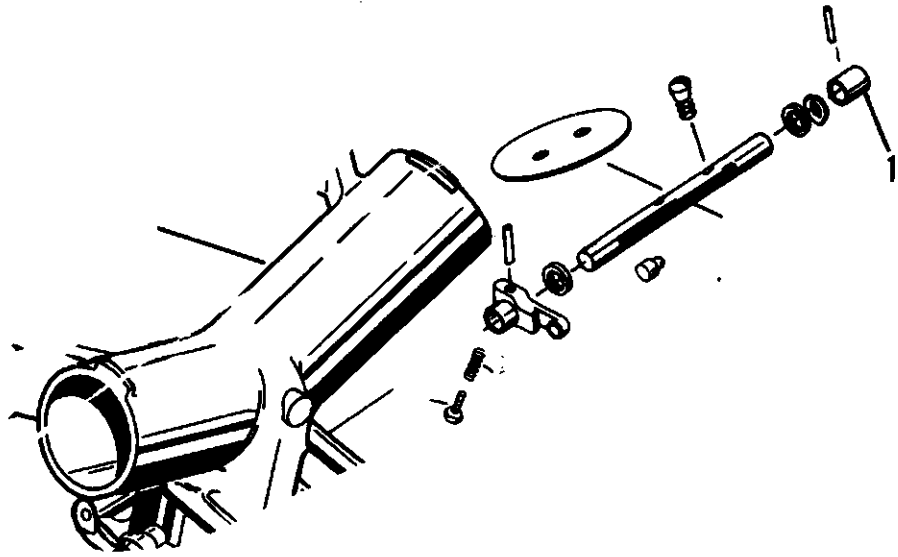

FIGURE & INDEX NO.	PART NUMBER	DESCRIPTION							UNITS PER ASS'Y.	
		1	2	3	4	5	6	7		
- 1	625238									1
	628308A2									1
	627888A1									1

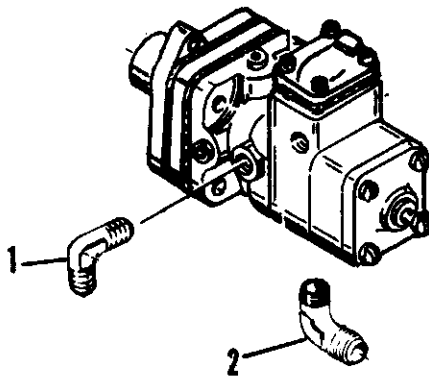

FIGURE & INDEX NO.	PART NUMBER	DESCRIPTION							UNITS PER ASS'Y.	
		1	2	3	4	5	6	7		
	630947-1A4									1
- 1	631882									1
- 2	628437									1

# 10-520-D SPEC 17

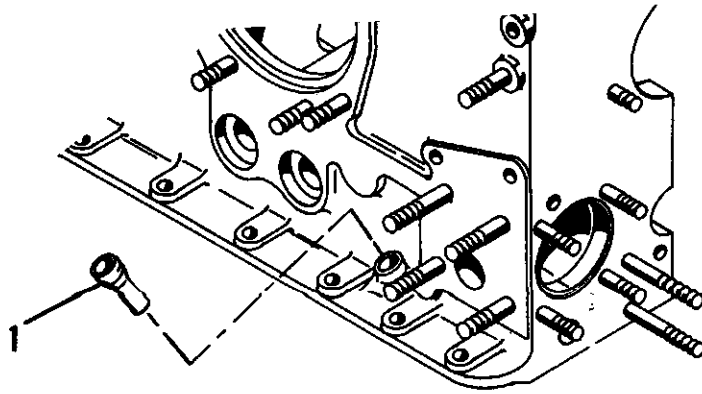
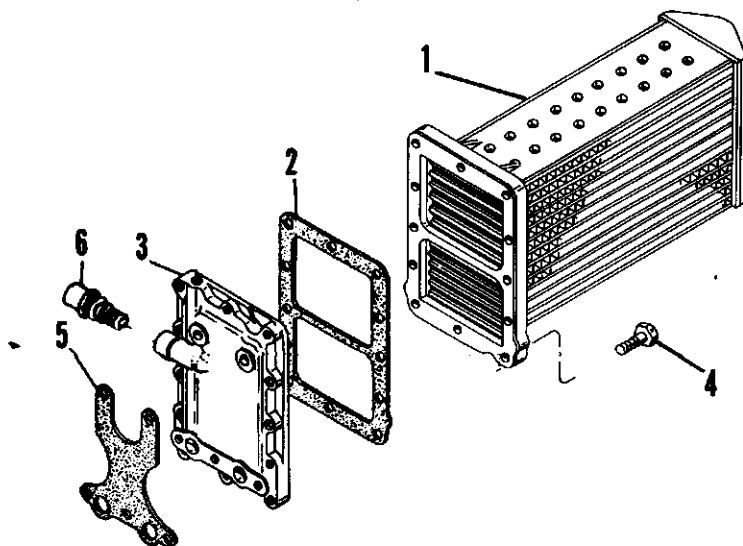
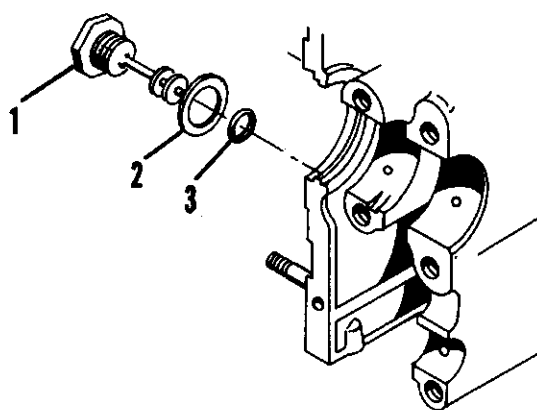

FIGURE & INDEX NO.	PART NUMBER	DESCRIPTION	UNITS PER ASS'Y.
- 1	631927	<div style="display: flex; justify-content: space-around; font-weight: bold; font-size: small;"> <span>1</span><span>2</span><span>3</span><span>4</span><span>5</span><span>6</span><span>7</span> </div> Housing, Oil Gage Rod . . . . .	1

# IO-520-F SPEC 2



INDEX NO.	PART NUMBER								DESCRIPTION	UNITS PER ASS'Y.
		1	2	3	4	5	6	7		
- 1	630050								Oil Cooler . . . . .	1
- 2	626342								Gasket, Oil Cooler to Plate . . . . .	1
- 3	626332								Plate, Oil Cooler . . . . .	1
- 4	535668								Screw . . . . .	12
- 5	632341								Gasket, Plate to Crankcase . . . . .	1
- 6	627702								Vernatherm, Control Assembly . . . . .	1



INDEX NO.	PART NUMBER								DESCRIPTION	UNITS PER ASS'Y.
		1	2	3	4	5	6	7		
- 1	626334								Plug, Special, Crankcase Vernatherm Hole . . . . .	1
- 2	625966								Gasket . . . . .	1
- 3	AN123866								O-Ring, Vernatherm Hole Plug . . . . .	1



# IO-520-F SPEC 2

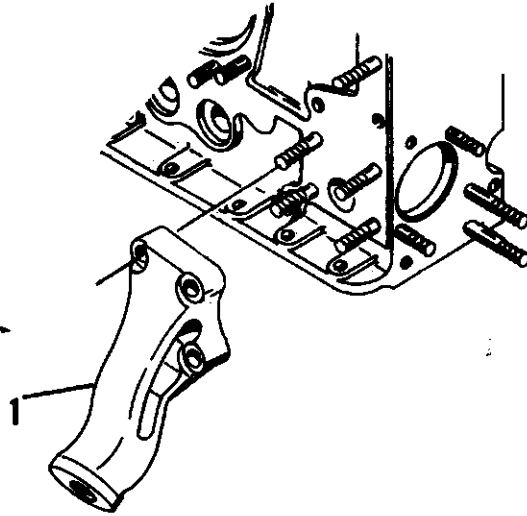

INDEX NO.	PART NUMBER	1	2	3	4	5	6	7	DESCRIPTION	UNITS PER ASS'Y.
- 1	539518								Bracket, Engine Mount . . . . .	4

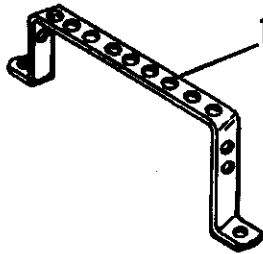

INDEX NO.	PART NUMBER	1	2	3	4	5	6	7	DESCRIPTION	UNITS PER ASS'Y.
- 1	626486								Bracket, Fuel Discharge Tube . . . . .	1

# IO-520-F SPEC 2

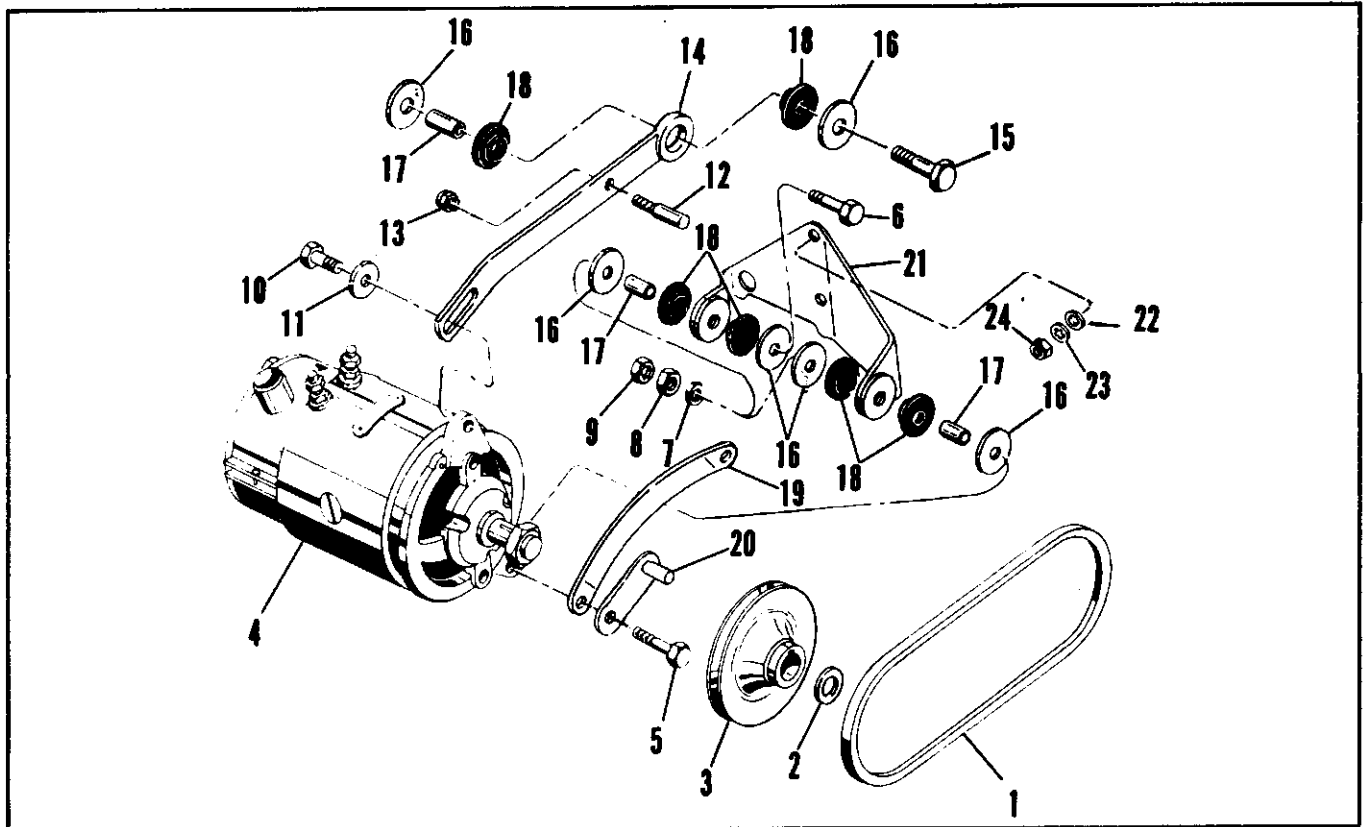

INDEX NO.	PART NUMBER	DESCRIPTION							UNITS PER ASS'Y.	
		1	2	3	4	5	6	7		
- 1	539547-31.19	Belt, Generator Driven . . . . .								1
- 2	536213	Spacer, Generator Driven . . . . .								1
- 3	627377	Sheave, Generator Driven . . . . .								1
- 4	627272	Generator, 12 Volt, 50 Amp. . . . .								1
ATTACHING PARTS										
- 5	AN5-20A	Bolt . . . . .								1
- 6	AN5-15A	Bolt . . . . .								1
- 7	2473	Washer, Plain . . . . .								1
- 8	AN315-5R	Nut, Plain, Hex . . . . .								2
- 9	2560	Palnut . . . . .								2
-10	AN75A6	Bolt . . . . .								1
-11	537539	Washer, Plain . . . . .								1
* - - - - *										
-12	627673	Idler, Kiss . . . . .								1
ATTACHING PARTS										
-13	22661	Nut, Self Locking, 1/4-28 . . . . .								1
* - - - - *										
-14	627276	Bracket, Generator Adjusting Arm . . . . .								1
-15	AN75A15	Screw . . . . .								1
-16	627279	Washer, Special . . . . .								6
-17	627281	Bushing, Spacer . . . . .								3
-18	627282	Bushing, Rubber . . . . .								6
-19	627068	Bracket, Generator Support . . . . .								1
-20	632112	Bracket Assembly, Kiss Idler . . . . .								1
-21	627690	Bracket, Generator Mounting . . . . .								1
-22	2794	Washer . . . . .								1
-23	AN936A516	Washer, Lock . . . . .								1
-24	AN315-5R	Nut, Plain, Hex . . . . .								1

# 10-520-F SPEC 2

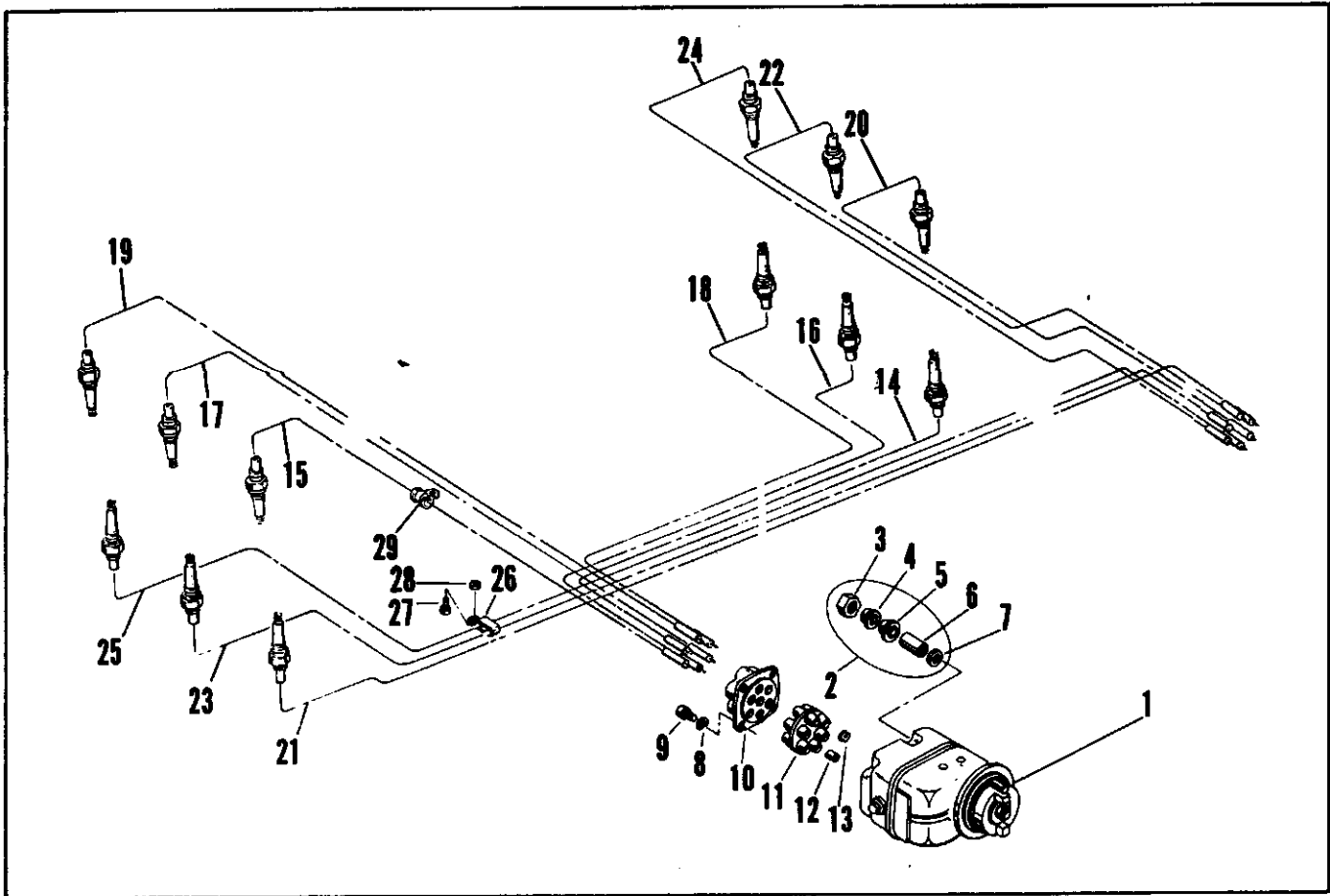
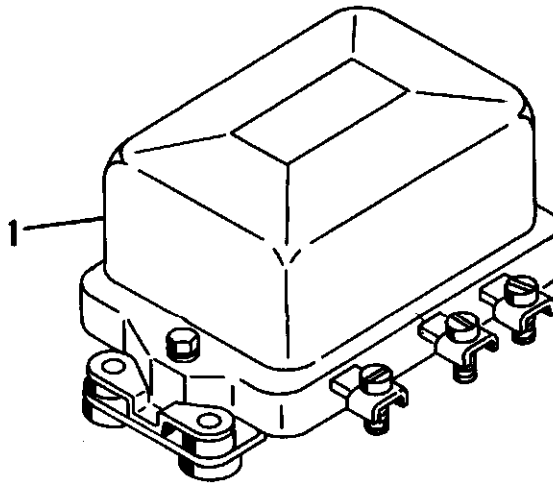

FIGURE & INDEX NO.	PART NUMBER	DESCRIPTION							UNITS PER ASSY.
		1	2	3	4	5	6	7	
- 1	631237	Magneto Assembly, Model S6RN-25							
		Bendix Scintilla No. 10-79020-10. . . . .							2
- 2	352024	Kit, Ground Terminal, L. H. & R. H. Magneto . . . . .							2
- 3	25318	. Nut, 5/8-24 . . . . .							1
- 4	25317	. Ferrule, Shielded Ground Wire, Outer . . . . .							1
- 5	25316	. Ferrule, Shielded Ground Wire, Inner . . . . .							1
- 6	530455	. Sleeve, Insulating . . . . .							1
- 7	25314	. Washer, Special . . . . .							1
- 8	25321	Washer, Lock . . . . .							8
- 9	25320	Screw, 10-32 X 5/8 In. Lg. . . . .							8
-10	25312	Plate, 6 Cylinder Shielded Cable Outlet . . . . .							2
-11	36219	Grommet, Plate . . . . .							2
-12	627001	Sleeve, Magneto Distributor Block . . . . .							12
-13	627002	Washer, Magneto Block . . . . .							12
	627805	Harness Assembly, Left Magneto . . . . .							1
-14	627040-36.94	. Cable Assembly, No. 1 Cylinder, Lower . . . . .							1
-15	627040-19.44	. Cable Assembly, No. 2 Cylinder, Upper . . . . .							1
-16	627040-37.19	. Cable Assembly, No. 3 Cylinder, Lower . . . . .							1
-17	627040-18.94	. Cable Assembly, No. 4 Cylinder, Upper . . . . .							1
-18	627040-42.19	. Cable Assembly, No. 5 Cylinder, Lower . . . . .							1
-19	627040-23.19	. Cable Assembly, No. 6 Cylinder, Upper . . . . .							1
	627804	Harness Assembly, Right Magneto . . . . .							1
-20	627040-16.19	. Cable Assembly, No. 1 Cylinder, Upper . . . . .							1
-21	627040-39.19	. Cable Assembly, No. 2 Cylinder, Lower . . . . .							1
-22	627040-19.44	. Cable Assembly, No. 3 Cylinder, Upper . . . . .							1
-23	627040-35.69	. Cable Assembly, No. 4 Cylinder, Lower . . . . .							1
-24	627040-22.69	. Cable Assembly, No. 5 Cylinder, Upper . . . . .							1
-25	627040-41.69	. Cable Assembly, No. 6 Cylinder, Lower . . . . .							1
-26	627921	Clamp, Ignition Harness . . . . .							2
-27	627759	Bolt, No. 6-32 X 5/16 In. Lg. . . . .							2
-28	627756	Nut, No. 6-32 . . . . .							2
-29	626577-2R	Clamp, Ignition Cable . . . . .							12

# IO-520-F SPEC 2



INDEX NO.	PART NUMBER	DESCRIPTION	UNITS PER ASS'Y.
- 1	627321	1 2 3 4 5 6 7 Regulator, Voltage, 12 Volt, 50 Amp. . . . .	1

# IO-520-F SPEC 3A

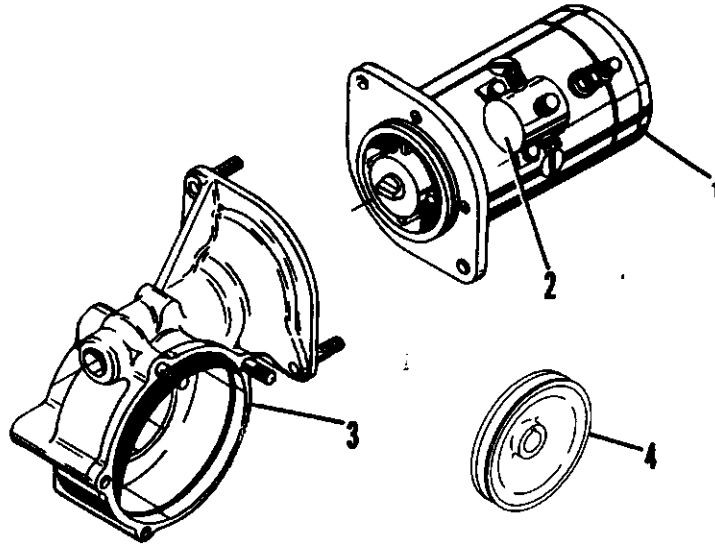

FIGURE & INDEX NO.	PART NUMBER								DESCRIPTION	UNITS PER ASS'Y.
		1	2	3	4	5	6	7		
- 1	634592								Starter . . . . .	1
- 2	634660								Magnetic Switch . . . . .	1
- 3	635050A4								Adapter Assembly, Starter . . . . .	1
- 4	635169								Sheave. . . . .	1